

“Frequency is Freedom”

Why?

- Get on your way sooner.
- No need to read a timetable.
- No need to live your life around it.
- Ability to change your plans at short notice.
- Missing a bus/train is less of a disaster.
- Easier / more reliable to make connections
- No need to waste time arriving at a place needlessly early.
- MORE CONVENIENT!**

Frequency

Often expressed in

- Bph: Buses per hour.
- Tph: Trains per hour
- Vph: Vehicles per hour.

Eg 2 Bph = A bus every 30 minutes.

What is Frequent?

- Generally at least 4 Vph
- At least every 15 minutes.
- Many frequent services use this benchmark around Australia and worldwide:

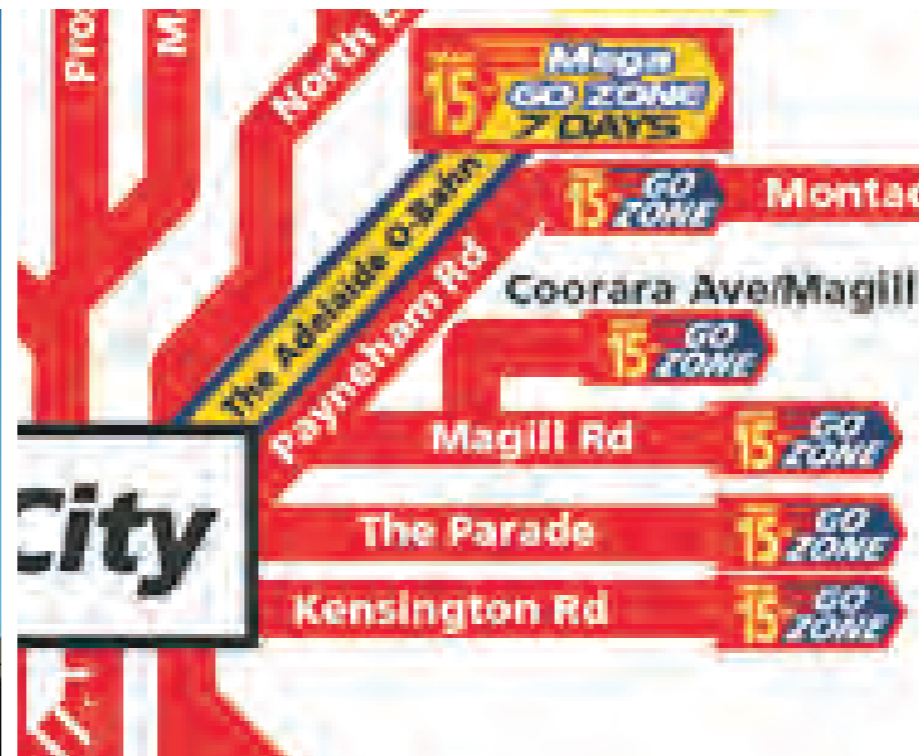

Who gets this in Brisbane?

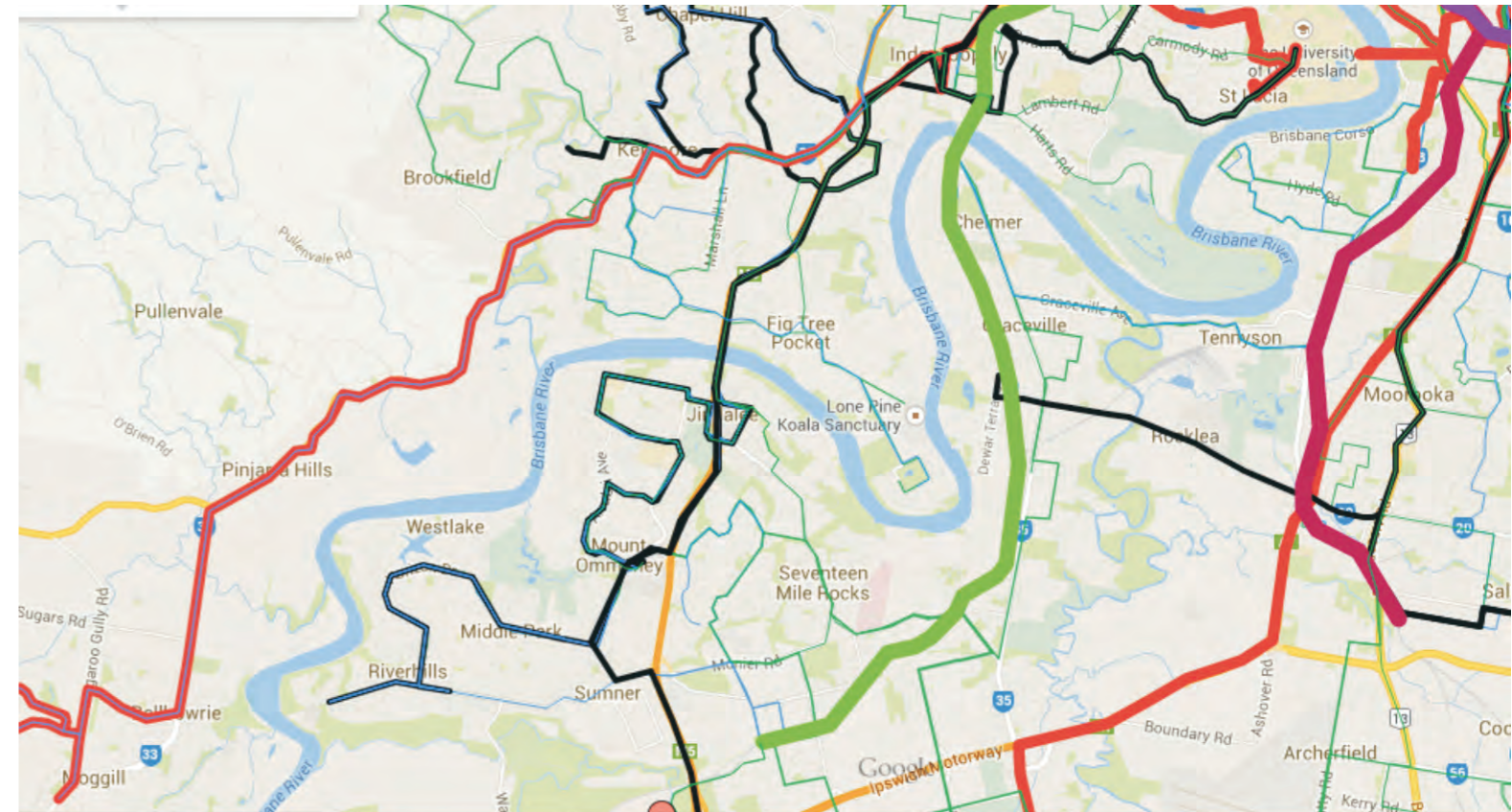
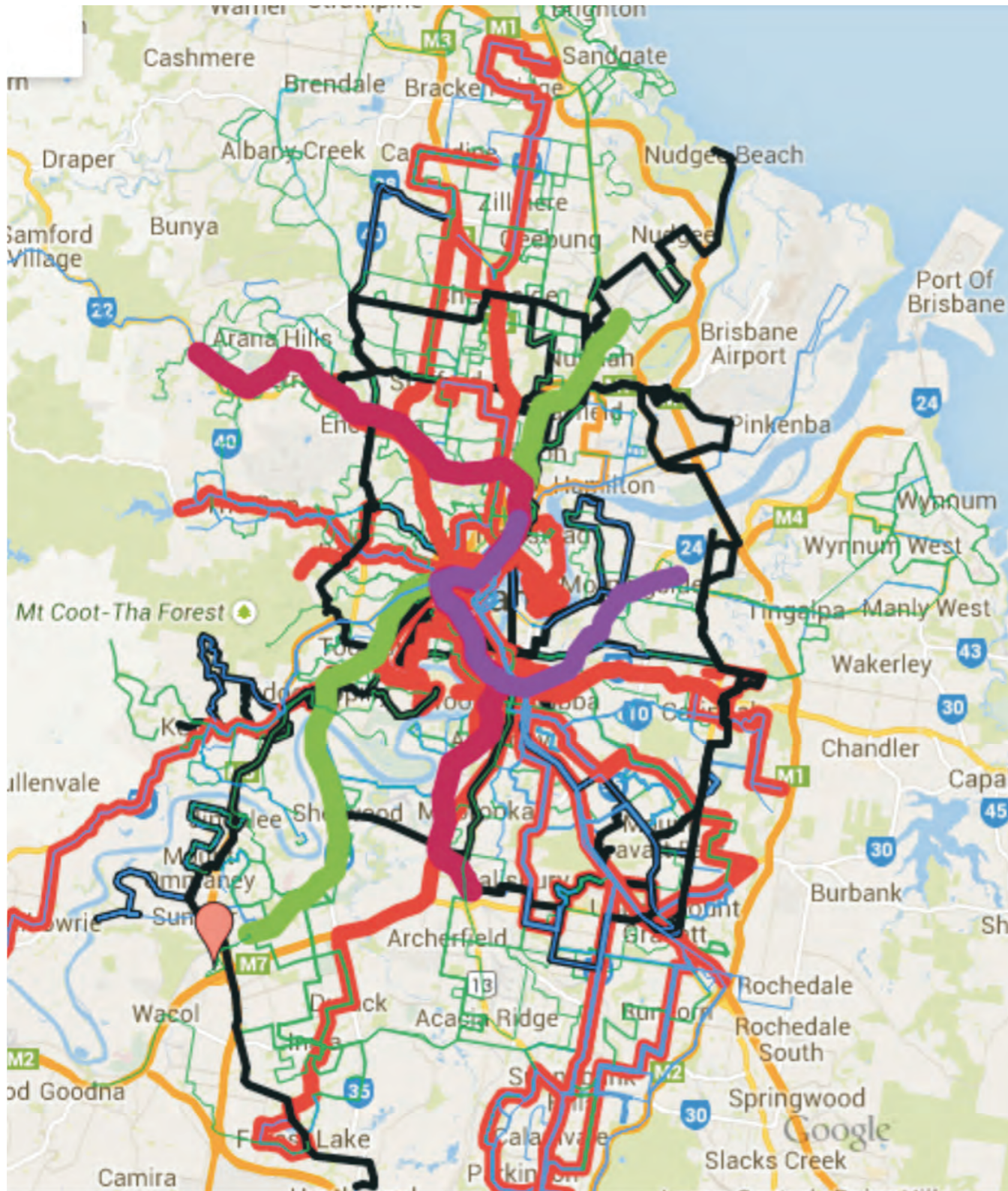

Current Frequent Coverage

Frequent routes: generally an 800m walk up.

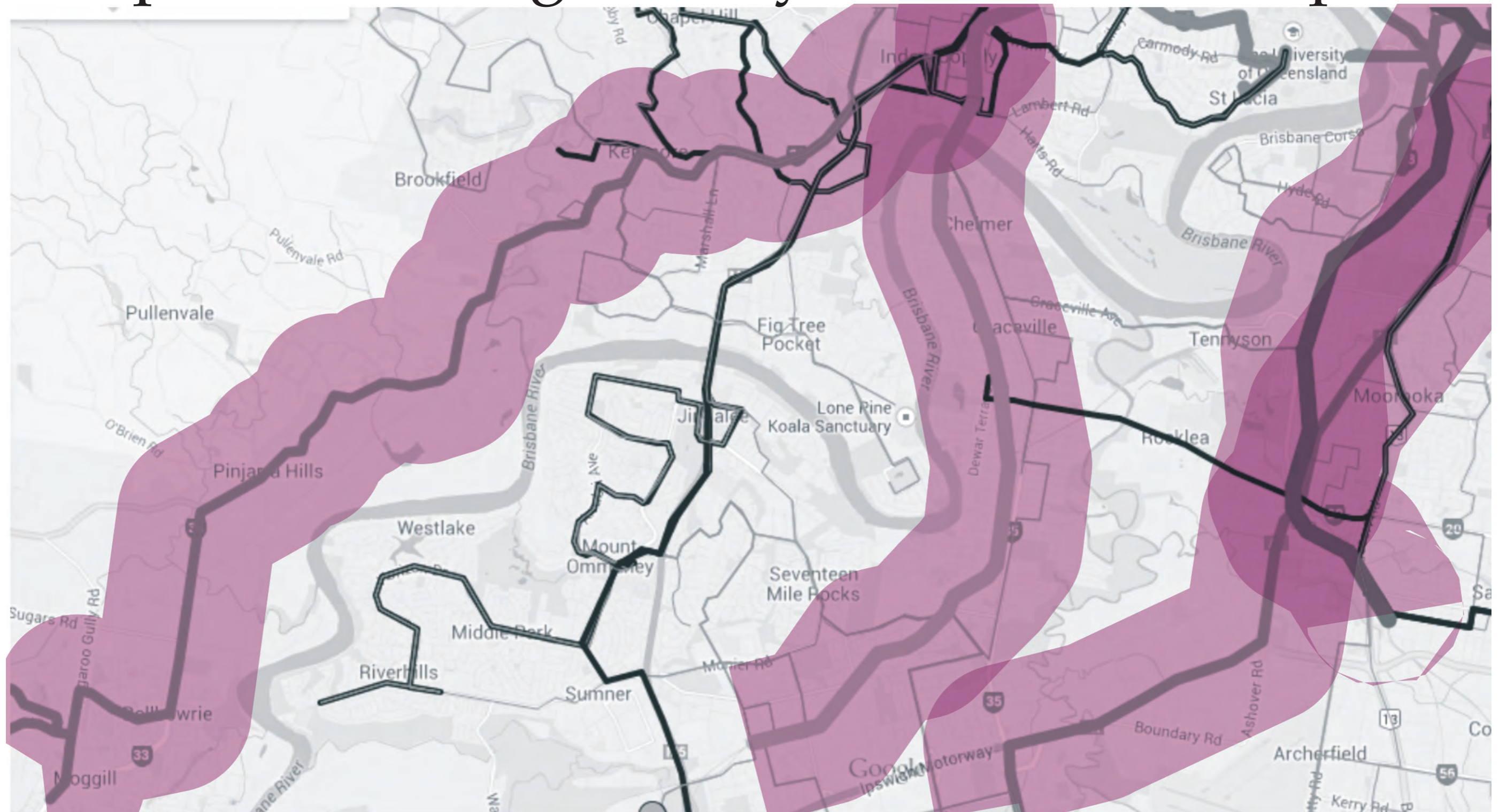

What it could be:

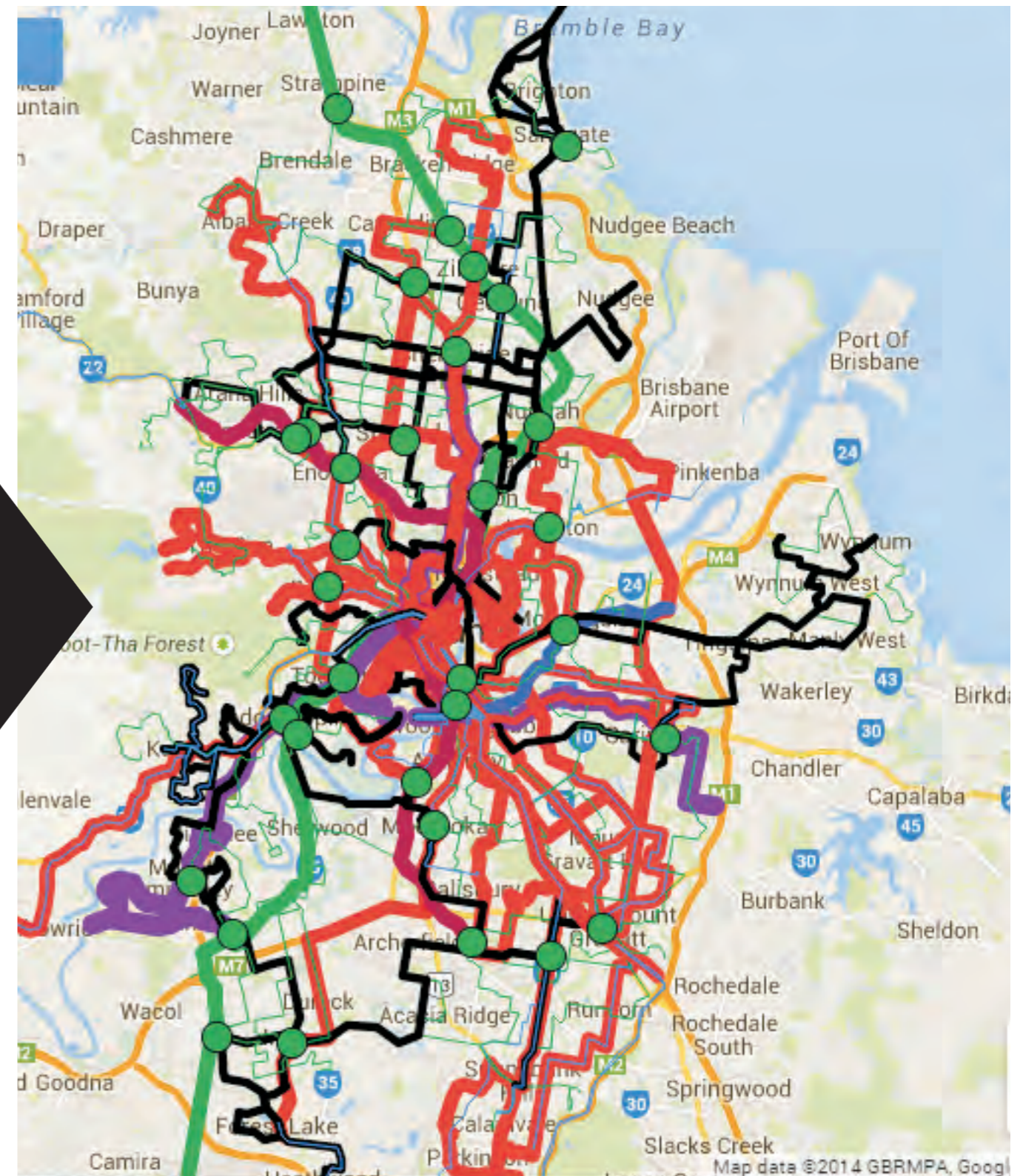
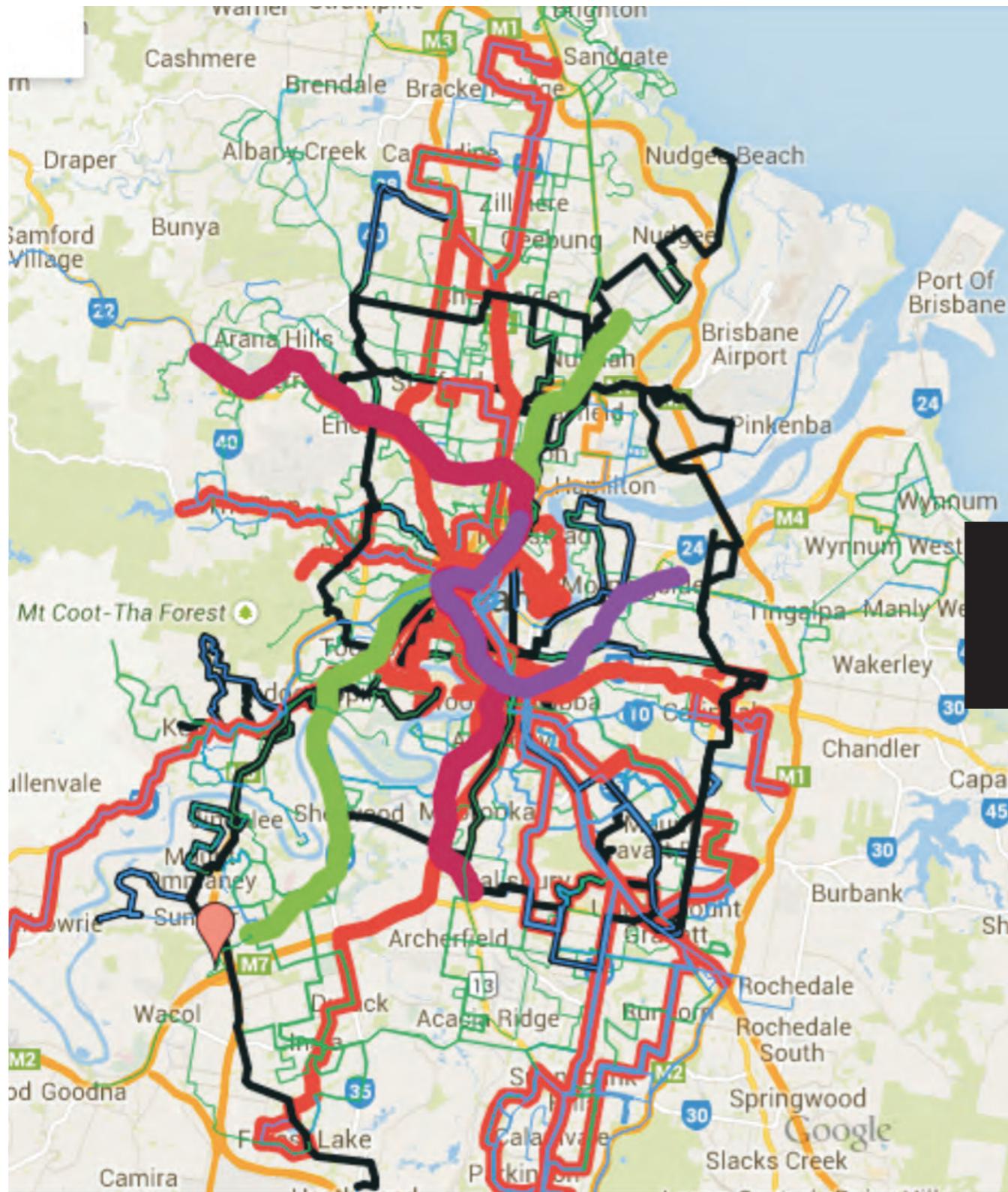

What it could be:

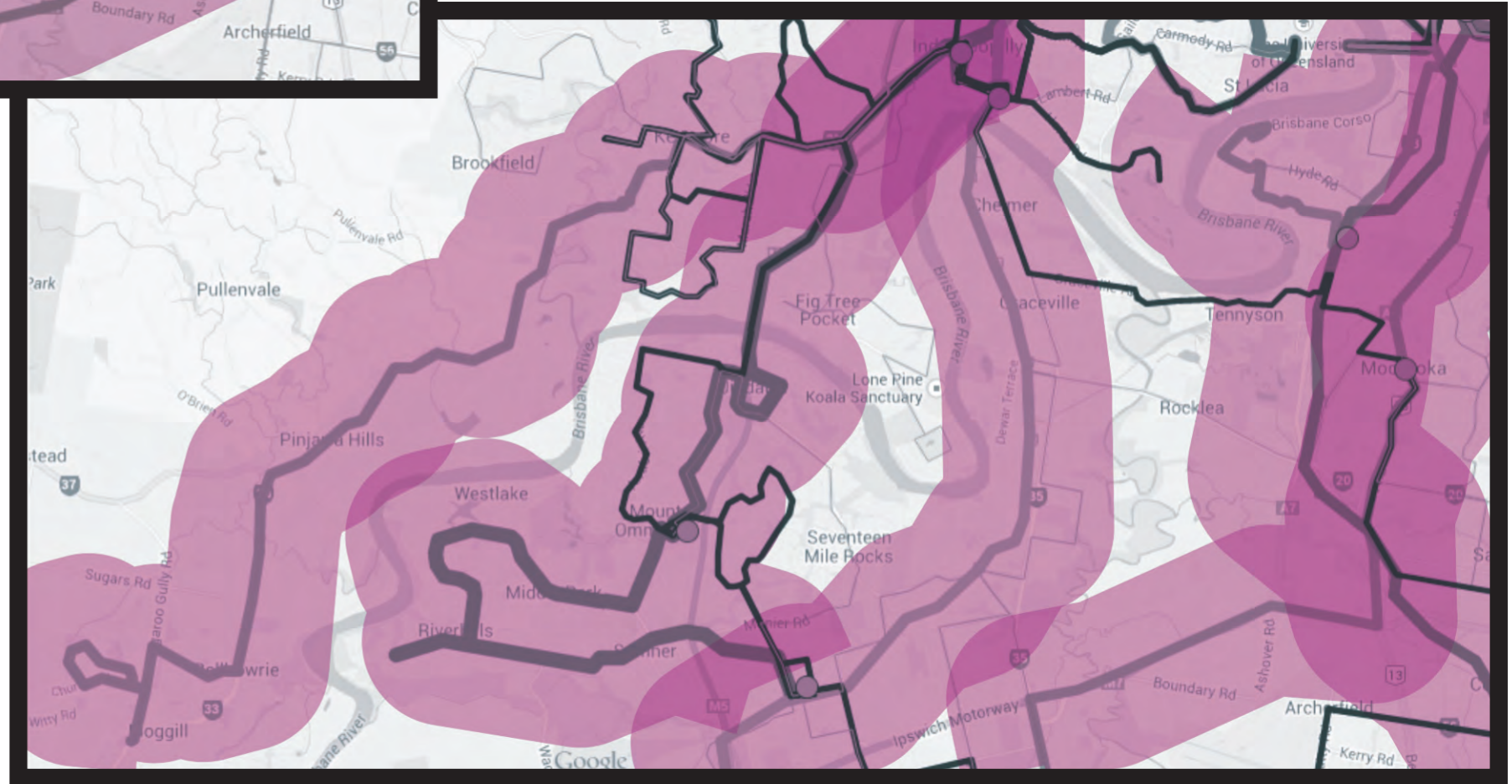
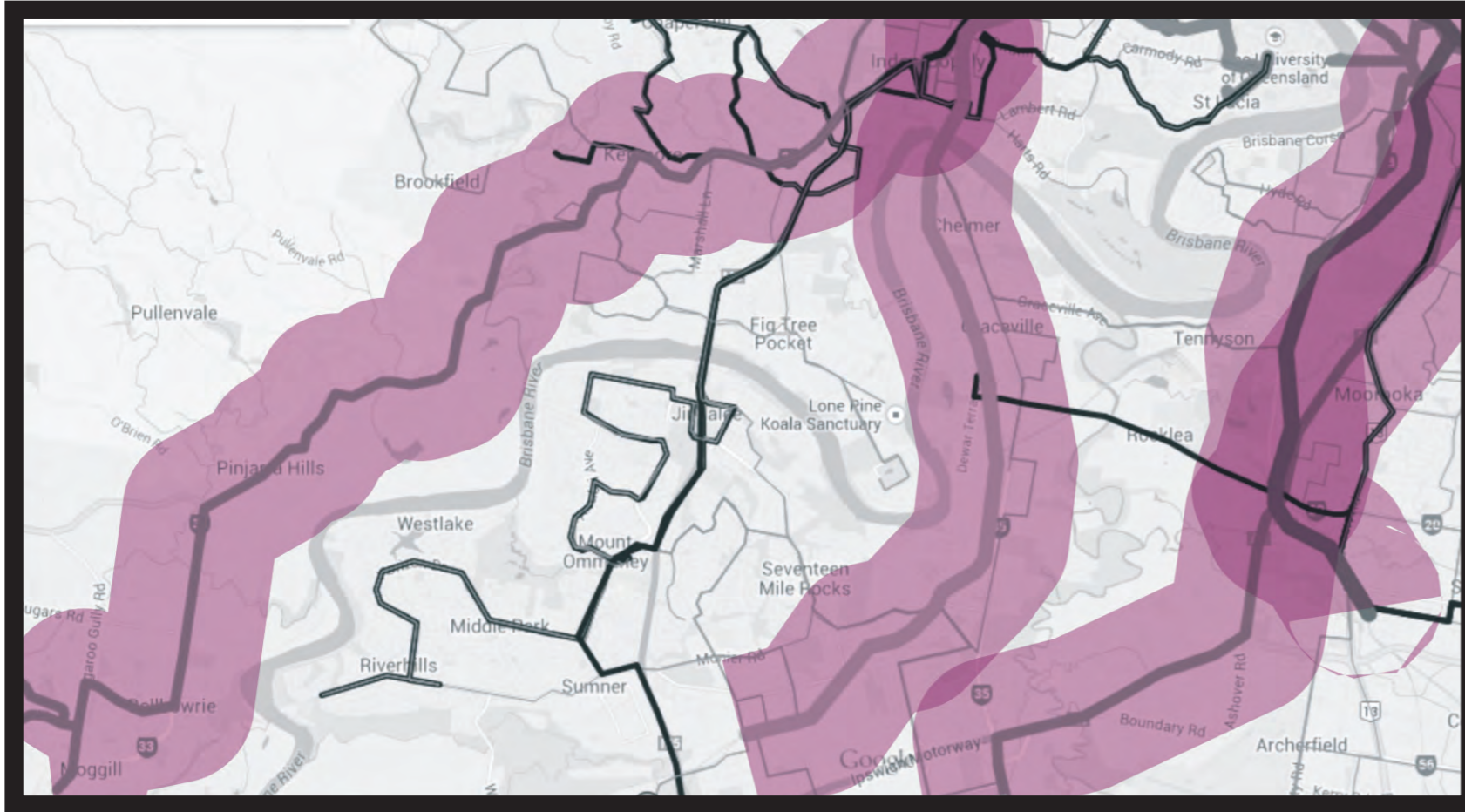

How?

Bus Reform

Bus Reform

Auckland are doing it!



Business as Usual

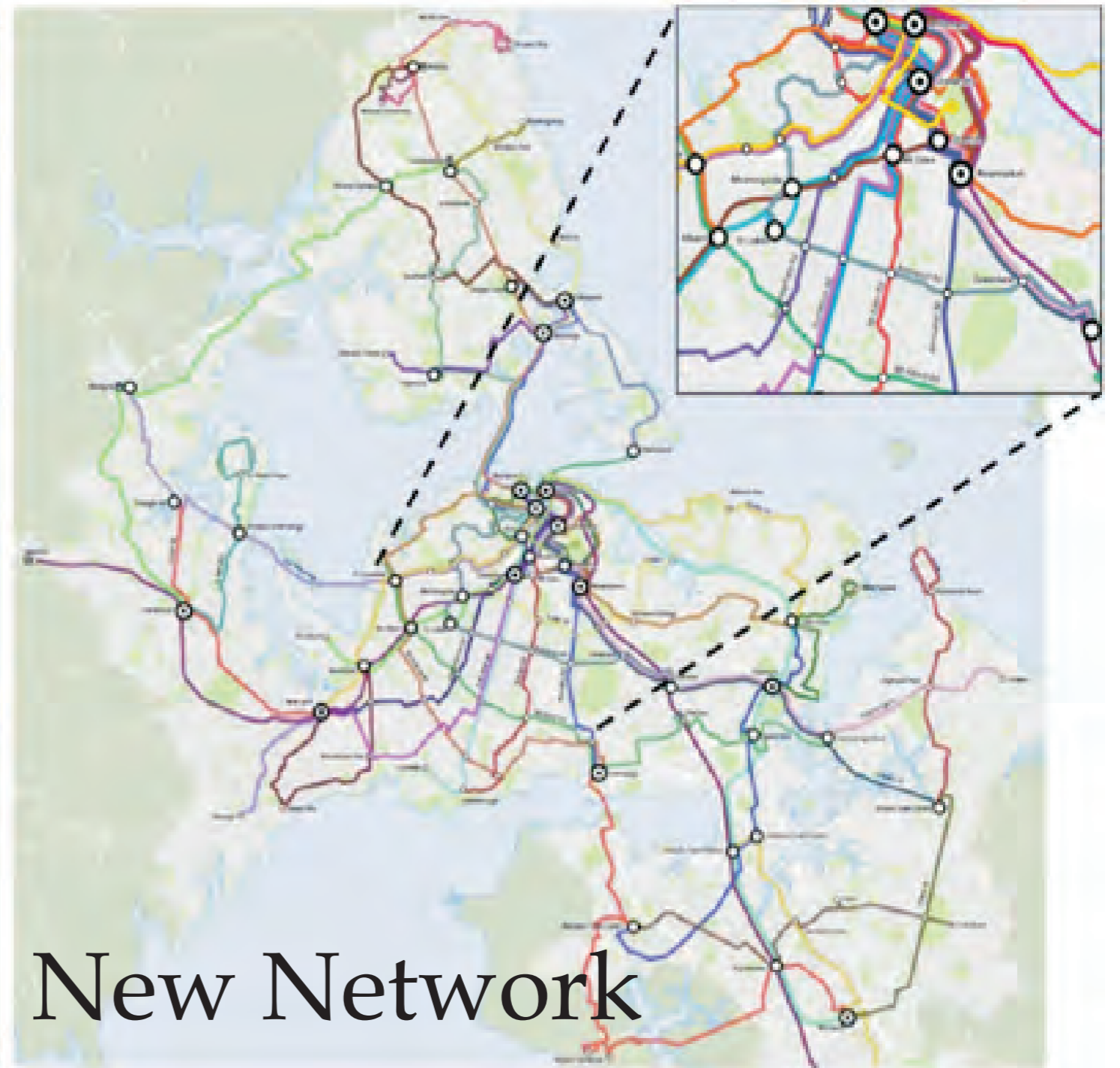

New Network

(Coloured lines = Frequent Routes)

Bus Basics

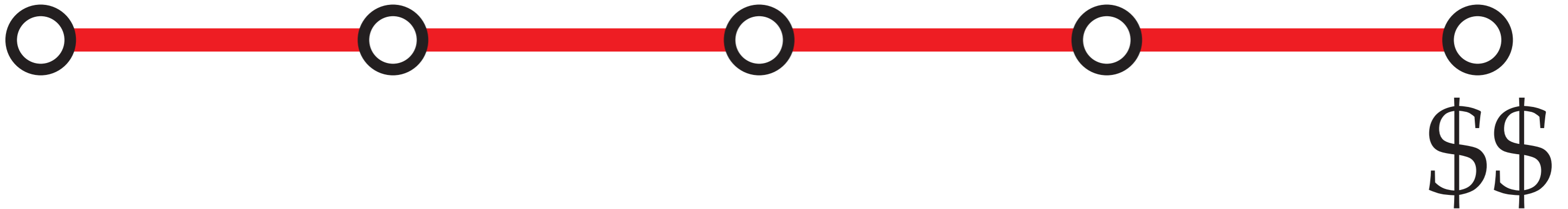
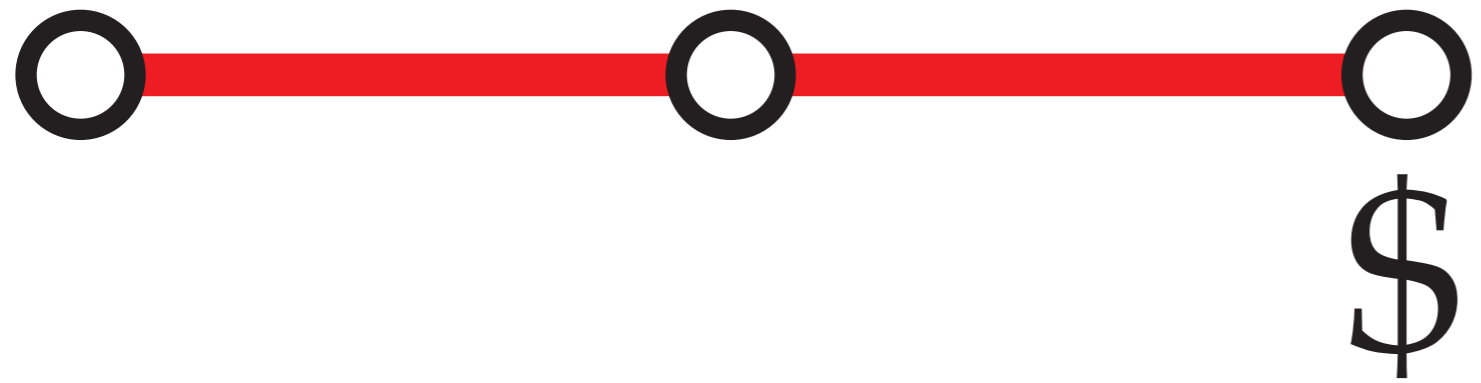

Double length (time) = Approx double the cost.

Bus Basics



Double frequency = Double Cost.

Brisbane Bus Issues

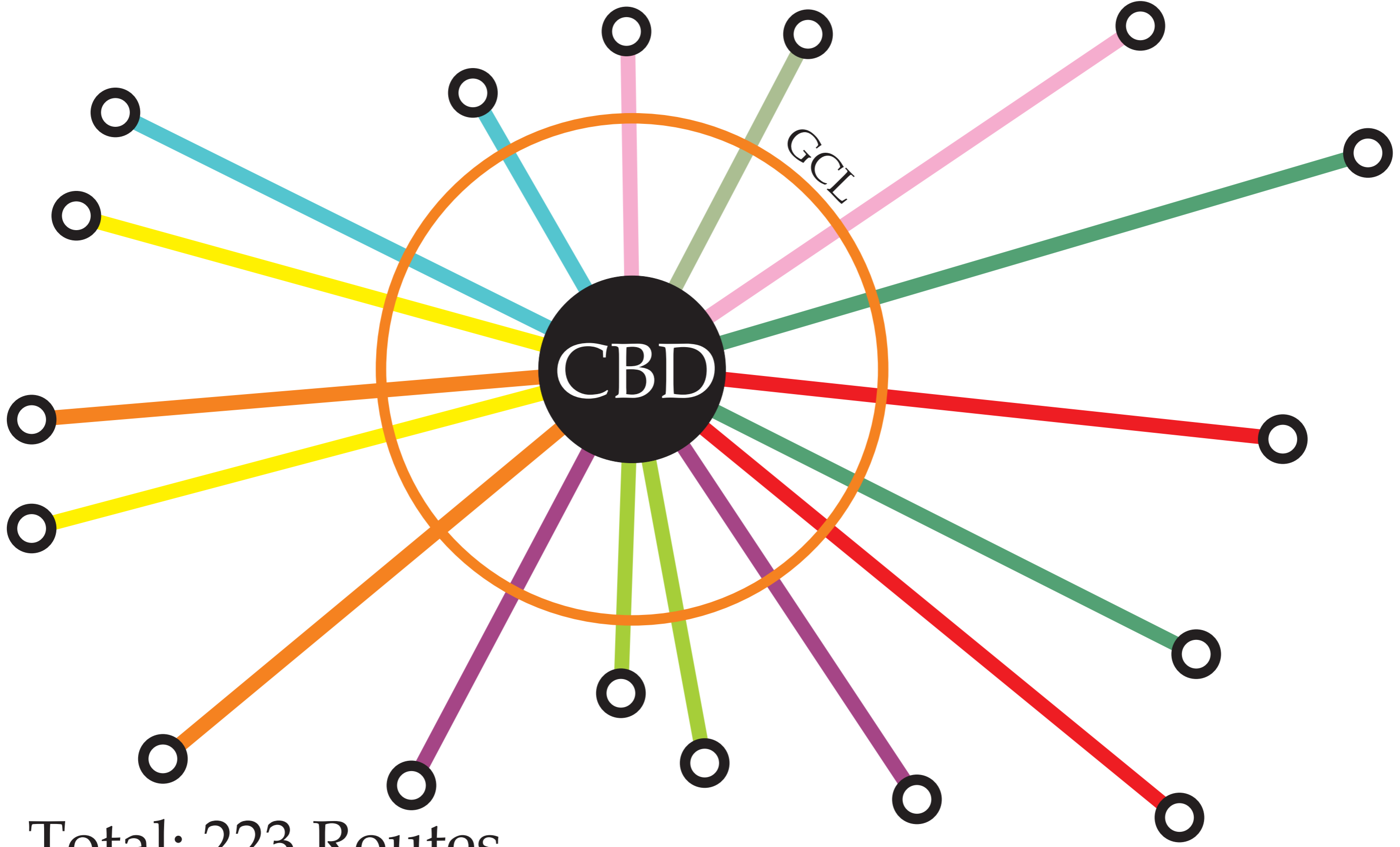

Total: 223 Routes.

Western Suburbs

Coronation Drive Corridor, 12pm-1pm, weekday.

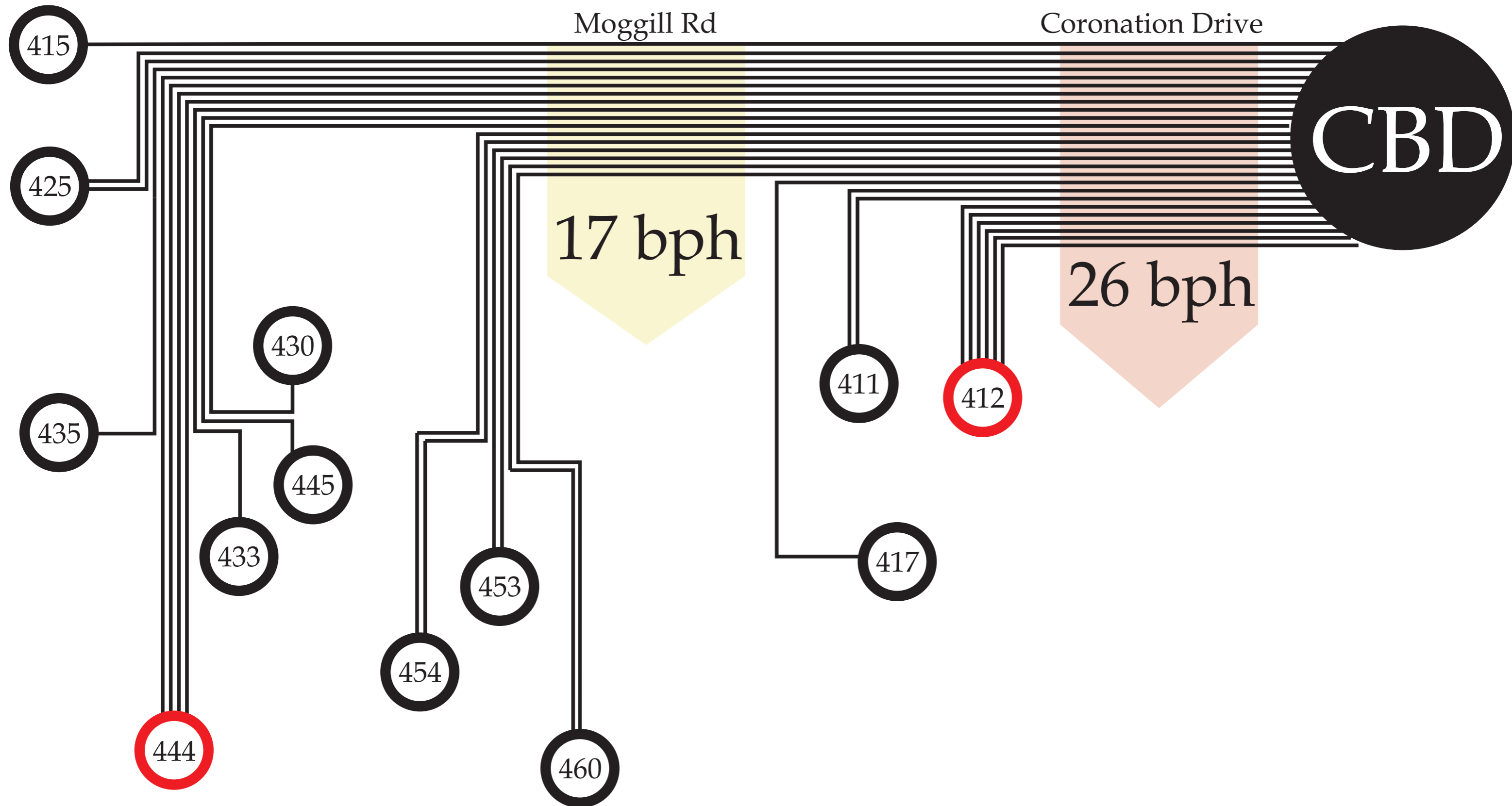

Brisbane Bus Issues

Not Enough Buses

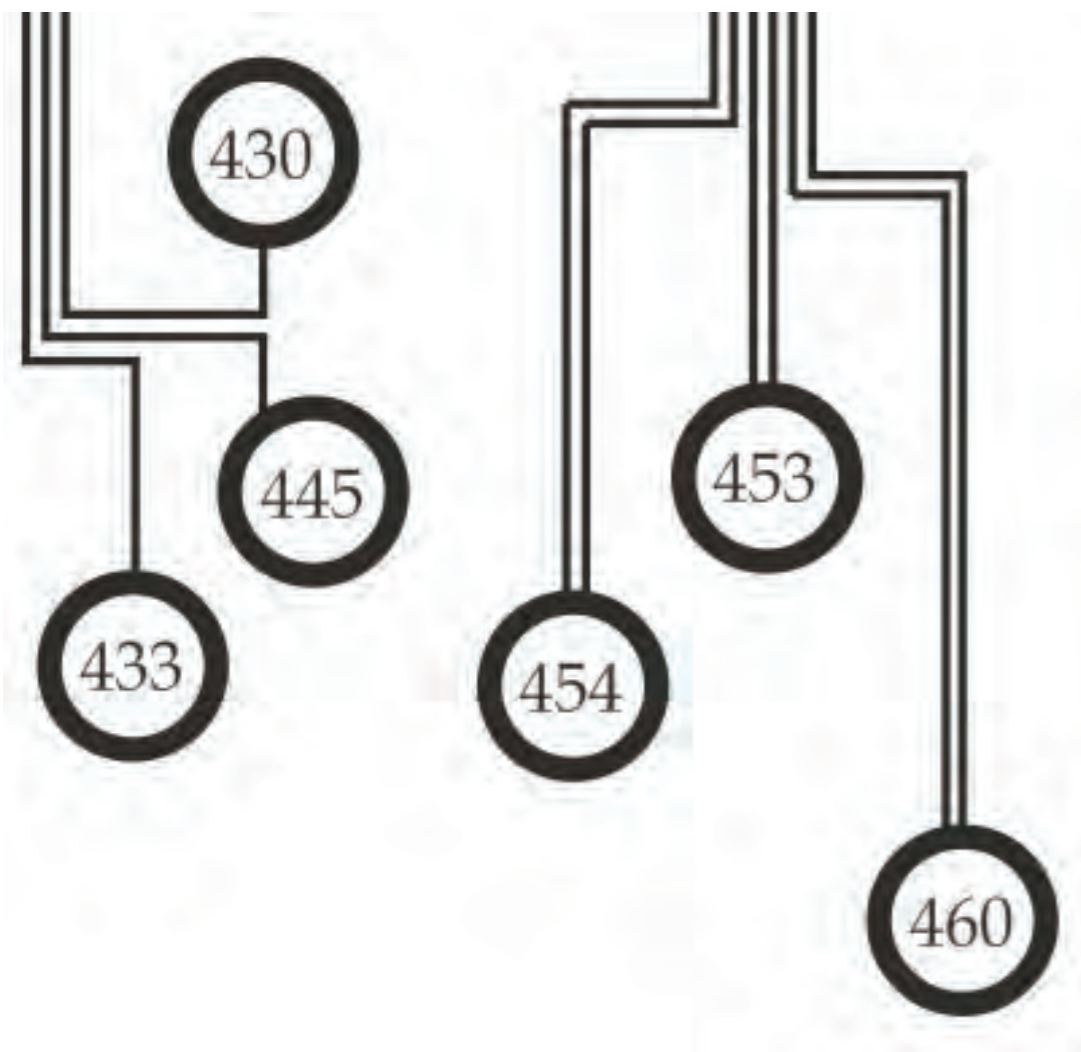

Moggill Rd

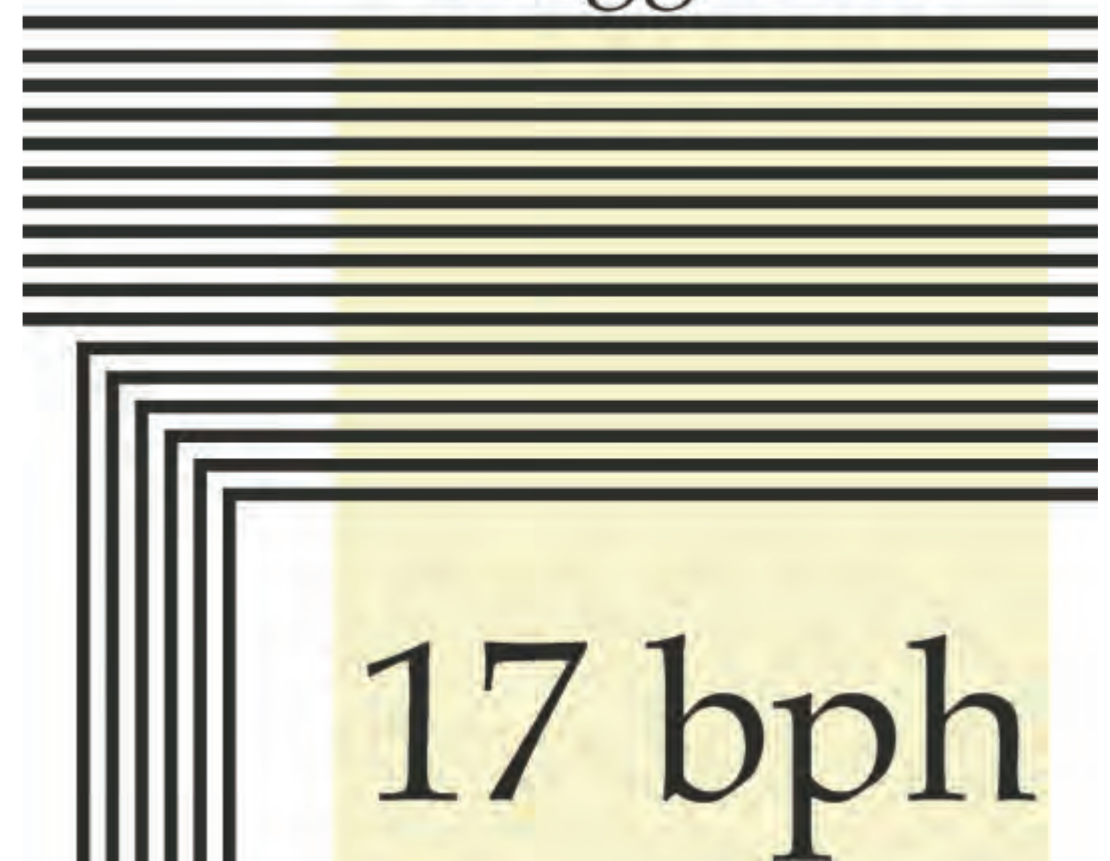

Too Many Buses

Brisbane Bus Issues

Not Enough Buses



Too Many Buses

Brisbane Bus Issues

Difficult to resource and balance needs

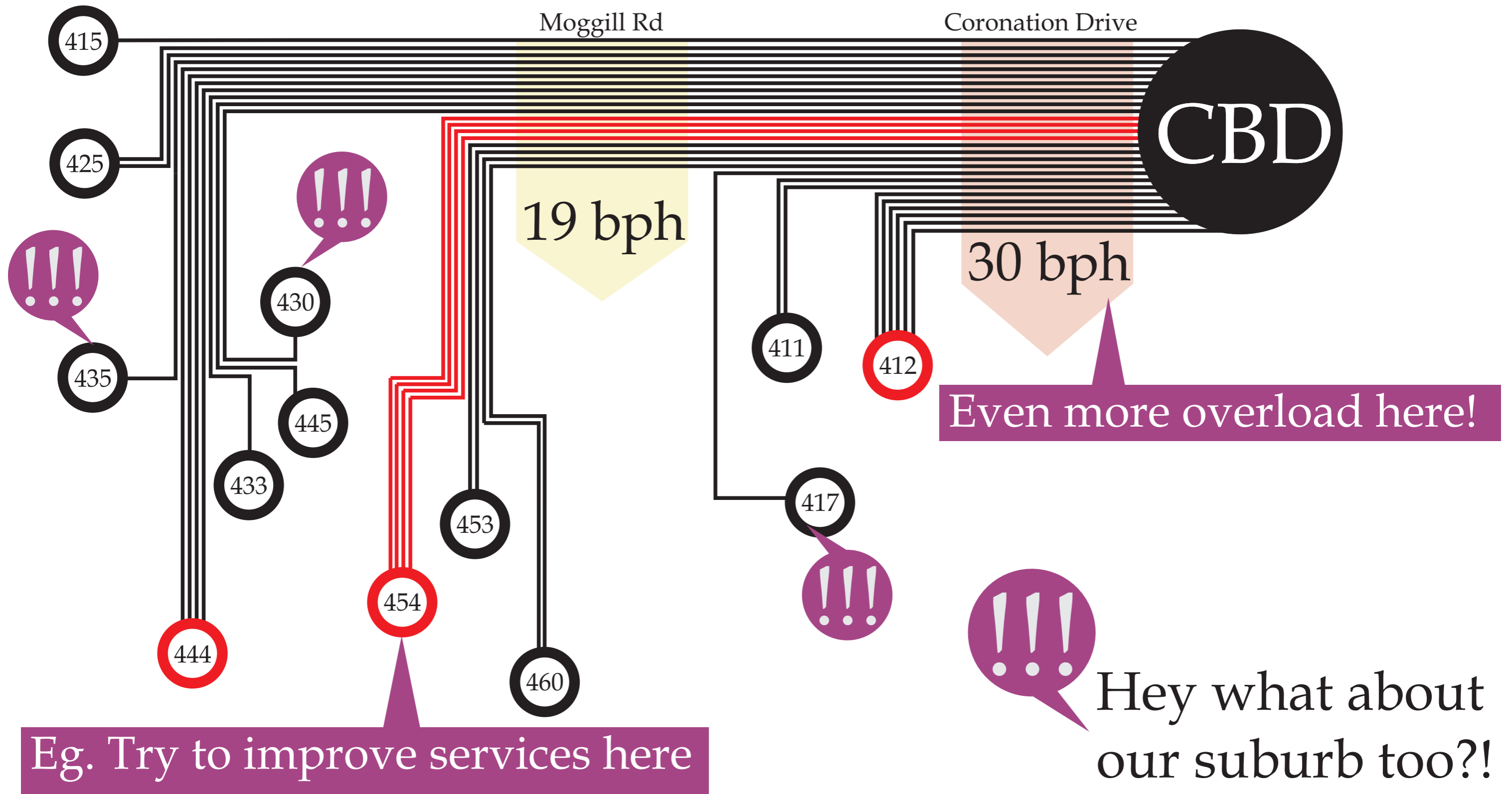

Brisbane Bus Issues



Hey what about
our suburb too?!

Brisbane Bus Issues

Complexity (Often a result of that approach)

route 450	route 453	route 454	route P455
servicing City Indooroopilly Jindalee/Mt Ommaney Riverhills	servicing City Indooroopilly Jindalee Mt Ommaney	servicing City Indooroopilly Mt Ommaney Shops Riverhills	servicing City Roma Street Mt Ommaney Shops Riverhills
route P456	route P457	route P458	route P459
servicing City Roma Street Jindalee Mt Ommaney	servicing City Jindalee/Mt Ommaney Riverhills	servicing City Jindalee Mt Ommaney	servicing City Mt Ommaney Shops Riverhills

Key

- route 450
- route 453
- route 454
- route P455
- route P456
- route P457
- route P458
- route P459
- bus stop
- terminus
- zone boundary
- connecting train station
- shopping centre
- cemetery
- hospital
- busway
- busway station
- tourist attraction
- bus interchange
- library
- park 'n' ride

diagrammatic map - not to scale

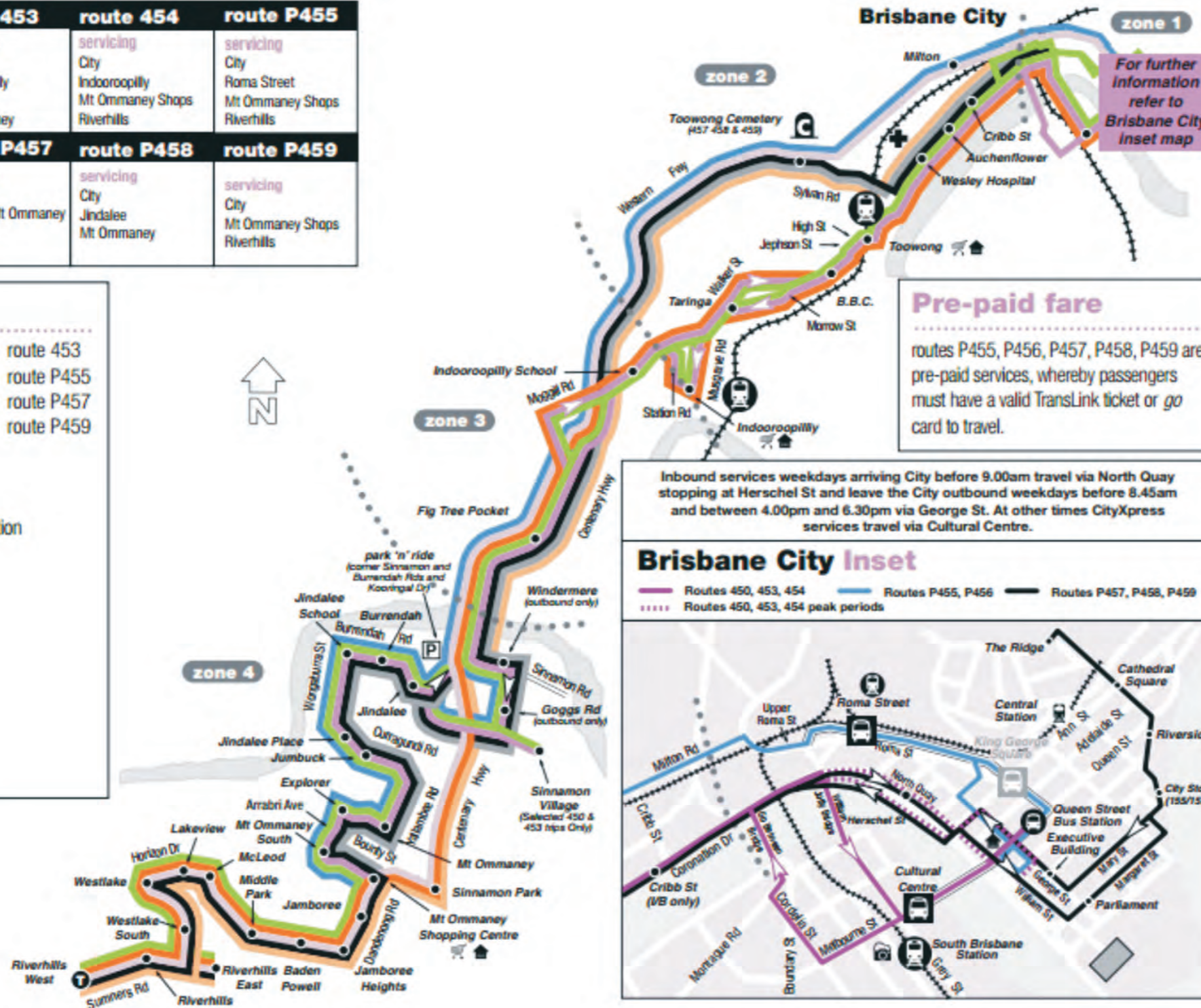

Brisbane Bus Issues

- Routes often Indirect.
- The way they've been since the 80s or earlier.
- City has changed.

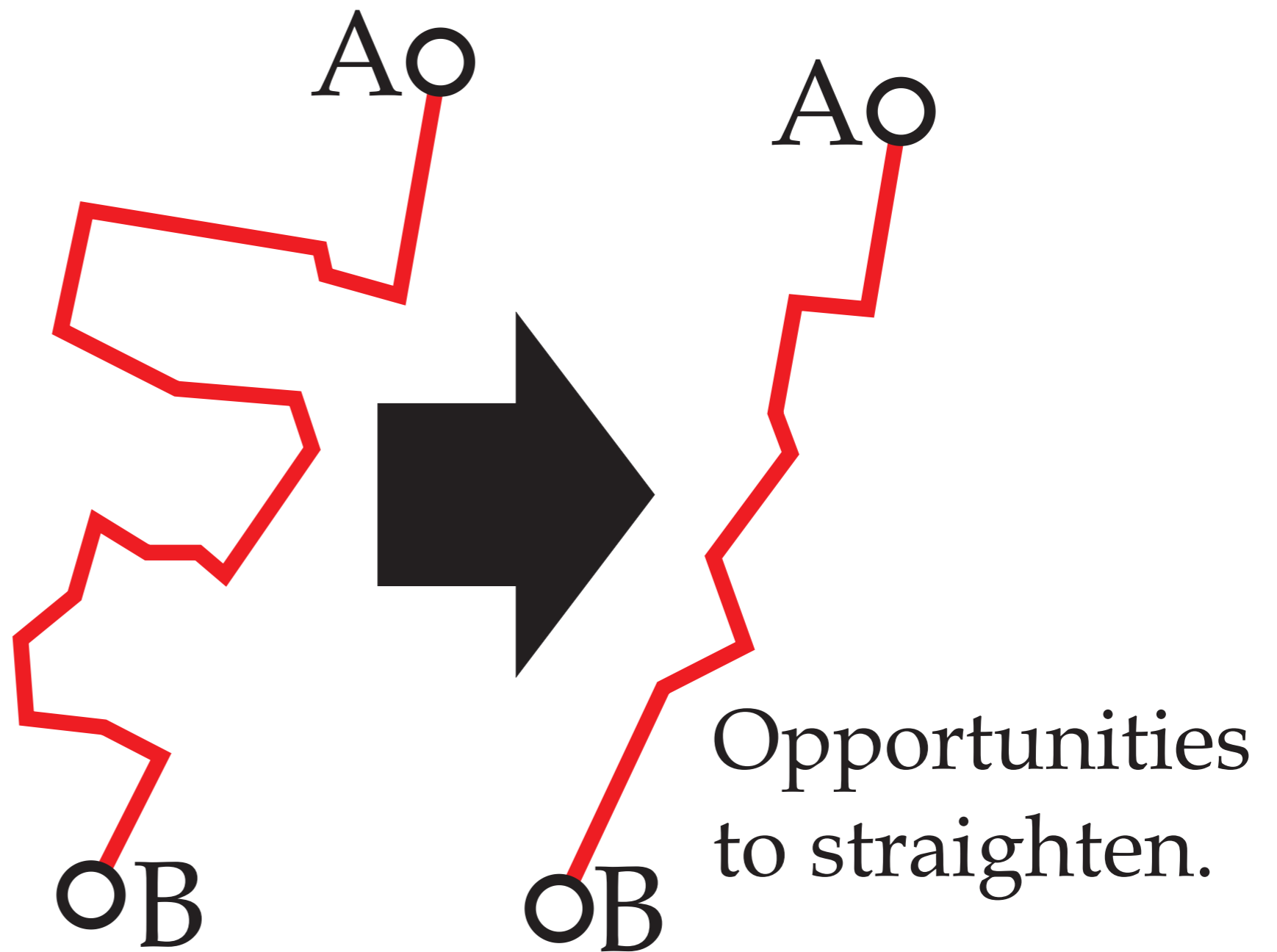
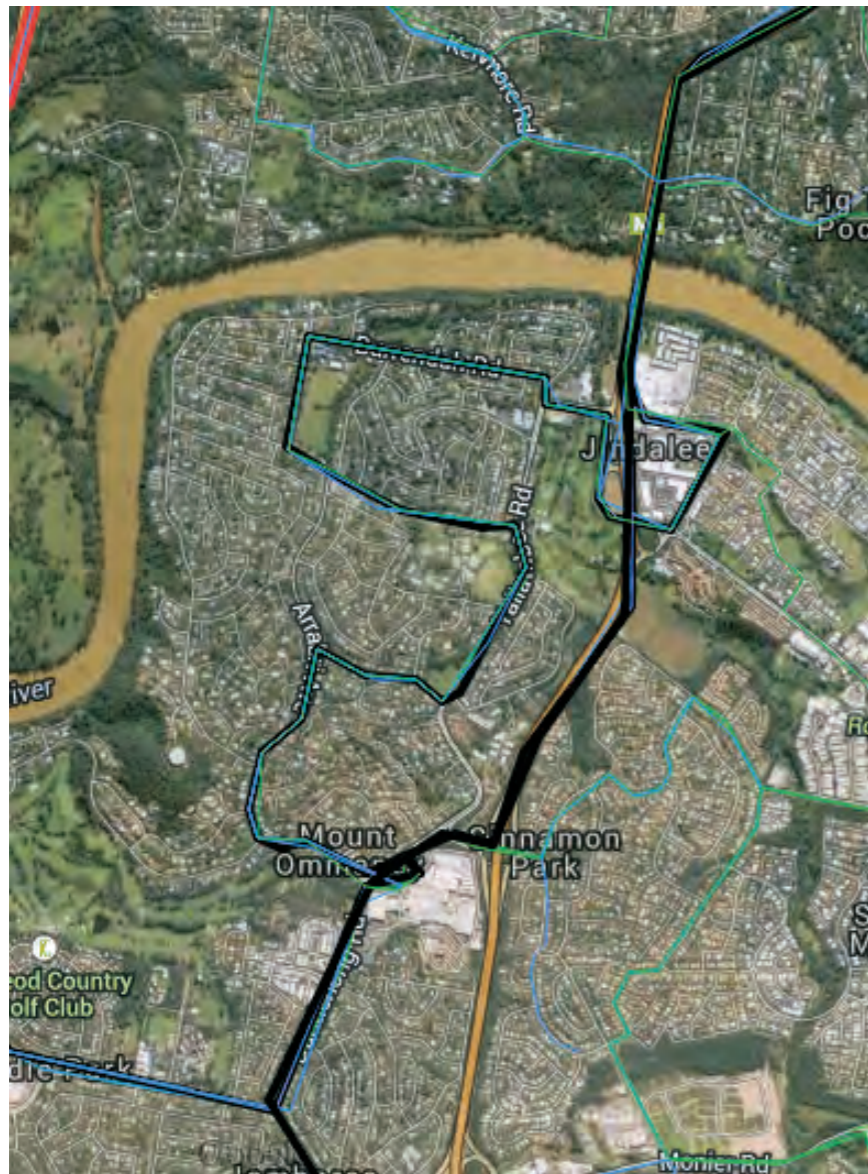

Brisbane Bus Issues

Lack of Frequency

Often no weekend services.

Slow and indirect.

Routes compete.

338 Strathpine - Albany Village - Aspley - Cherside

Effective: 20 February 2012

Monday to Friday														
Route Number	338	338	338	338	338	338	338	338	338	338	338	338	338	338
	am	am	am	am	am	am	am	am	am	pm	pm	pm	pm	pm
Train from Caboolture arrives				P6:53	P7:59	9:20	9:50	10:50	11:50	12:50	1:50	2:50	3:50	5:22
Train from City arrives				6:42	7:42	9:12	9:42	10:42	11:42	12:42	1:42	2:42	3:42	5:12
Strathpine (departs)				6:58	8:00	9:22	9:52	10:52	11:52	12:52	1:52	2:52	4:00	5:22
Brendale				7:07	D8:10	9:30	10:00	11:00	12:00	1:00	2:00	3:00	4:10	5:32
Saraband & Queen Elizabeth Drive	6:00	6:30	6:53	7:10	8:15	9:33	10:03	11:03	12:03	1:03	2:03	3:03	4:13	5:35
Saraband at Eatonvale	6:02	6:32	6:55	7:12	8:17	9:35	10:05	11:05	12:05	1:05	2:05	3:05	4:15	5:37
Albany Village	6:10	6:40	7:03	7:22	8:32	A9:45	A10:15	A11:15	A12:15	A1:15	A2:15	A3:15	4:25	5:47
Aspley Hypermarket "C"	6:25	6:55	7:20	B7:40	8:53	10:01	10:31	11:31	12:31	1:31	2:31	3:31	4:40	5:59
Cherside Interchange	6:33	7:03	7:30	C7:51	9:05	10:12	10:42	11:42	12:42	1:42	2:42	3:42	4:50	6:09

Services observe all CityXpress stops along Gympie Rd, between Aspley Hypermarket and Cherside Interchange except journey marked B.
A – Service operates via Aveo Albany Creek. After departure from Aveo Albany Creek, journey travels (R) to Explorer Drive, (L) Albany Forest Drive and (R) to Old Northern Rd. These journeys will service the "Explorer" stop on Albany Forest Drive BUT will not service the "Leisure Centre" stop.
B – DURING SCHOOL TERMS service travels via Maundrell Tce to Craigslea High School, then Hamilton Road to Cherside.
C – Wavell High students can transfer at Cherside to Route 322 departing at 7:55am or Route 320 departing at 7:55am.
D – DURING SCHOOL TERMS, service travels via Eatons Hill and Albany Creek State School.
P – Train arrives from Petrie.

Saturday						
Route Number	338	338	338	338	338	338
	am	am	am	pm	pm	pm
Train from Caboolture arrives		9:20	11:20	1:50	3:20	4:50
Train from City arrives		9:12	11:12	1:42	3:12	4:42
Strathpine		9:25	11:25	1:50	3:20	5:10
Brendale	7:50	9:33	11:33	1:58	3:28	5:18
Saraband & Queen Elizabeth Drive	7:53	9:36	11:36	2:01	3:31	5:21
Saraband at Eatonvale	7:55	9:38	11:38	2:03	3:33	5:23
Albany Village	A8:05	A9:45	A11:48	A2:13	A3:43	A5:33
Aspley Hypermarket "C"	8:20	10:04	12:04	2:29	3:59	5:49
Cherside Interchange	8:30	10:20	12:15	2:40	4:10	6:00

Services observe all CityXpress stops along Gympie Rd, from Aspley Hypermarket to Cherside Interchange.
A – Operates via Aveo Albany Creek then (R) Explorer Drv (L) Albany Forest Drive (servicing the "Explorer" Express Stop if required), (R) Old Northern Rd and usual route.

Sunday & Public Holidays						
Route Number	338	338	338	338	338	338
	am	am	am	pm	pm	pm
Train from Caboolture arrives		9:20	11:20	1:50	3:20	4:50
Train from City arrives			11:12	1:42	3:12	4:42
Strathpine		9:25	11:25	1:50	3:20	5:10
Brendale	7:50	9:33	11:33	1:58	3:28	5:18
Saraband & Queen Elizabeth Drive	7:53	9:36	11:36	2:01	3:31	5:21
Saraband at Eatonvale	7:55	9:38	11:38	2:03	3:33	5:23
Albany Village	A8:05	A9:45	A11:48	A2:13	A3:43	A5:33
Aspley Hypermarket "C"	8:20	10:04	12:04	2:29	3:59	5:49
Cherside Interchange	8:30	10:12	12:15	2:40	4:10	6:00

Services observe all CityXpress stops along Gympie Rd, from Aspley Hypermarket to Cherside Interchange.
A – Operates via Aveo Albany Creek then (R) Explorer Drv (L) Albany Forest Drive (servicing the "Explorer" Express Stop if required), (R) Old Northern Rd and usual route.



..... "I'll drive instead"

Brisbane Bus Issues

Repeated issues across the city.

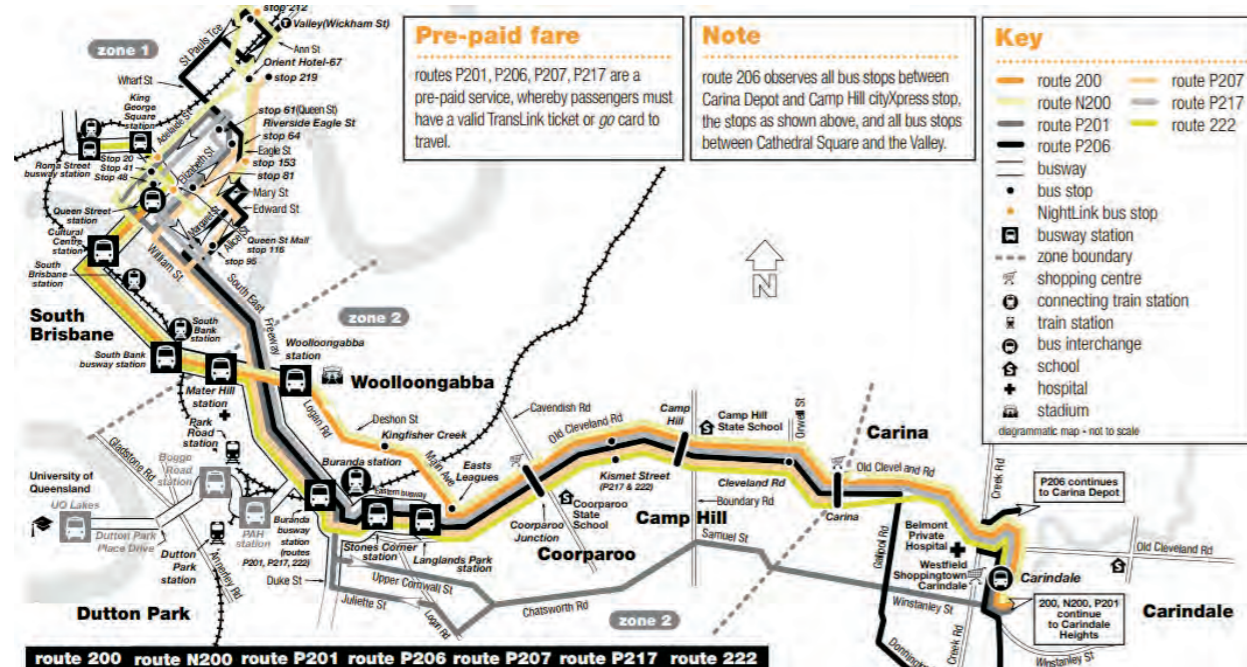

Saturday, Sunday & public holidays

Route Number	359	359	359	359	359	359	359	359	359	359	359	359	359
	am	am	am	am	am	pm	pm	pm	pm	pm	pm	pm	pm
Eatonvale	8:15	9:15	10:15	11:15	12:15	1:15	2:15	3:15	4:15	5:15	6:10	7:10	8:05
Albany Village	8:22	9:22	10:22	11:22	12:22	1:22	2:22	3:22	4:22	5:22	6:17	7:17	8:12
Explorer	8:28	9:28	10:28	11:28	12:26	1:26	2:26	3:26	4:26	5:26	6:21	7:21	8:16
Boulevard	8:35	9:35	10:35	11:35	12:32	1:32	2:32	3:32	4:32	5:32	6:27	7:27	8:22
Everton Park	8:42	9:42	10:42	11:42	12:39	1:39	2:39	3:39	4:39	5:39	6:34	7:34	8:29
Enoggera	8:45	9:45	10:45	11:45	12:42	1:42	2:42	3:42	4:42	5:42	6:37	7:37	8:32
Kelvin Grove	8:54	9:54	10:54	11:54	12:51	1:51	2:51	3:51	4:51	5:51	6:44	7:44	8:39
Normanby station, platform 2	8:58	9:58	10:58	11:58	12:55	1:55	2:55	3:55	4:55	5:55	6:47	7:47	8:42
Roma St busway station, platform 2	9:00	10:00	11:00	12:00	12:57	1:57	2:57	3:57	4:57	5:57	6:49	7:49	8:44
City, Queen St app Creek St (Stop 59)	9:08	10:08	11:08	12:08	1:05	2:05	3:05	4:05	5:05	6:05	6:56	7:56	8:51

Bus Reform

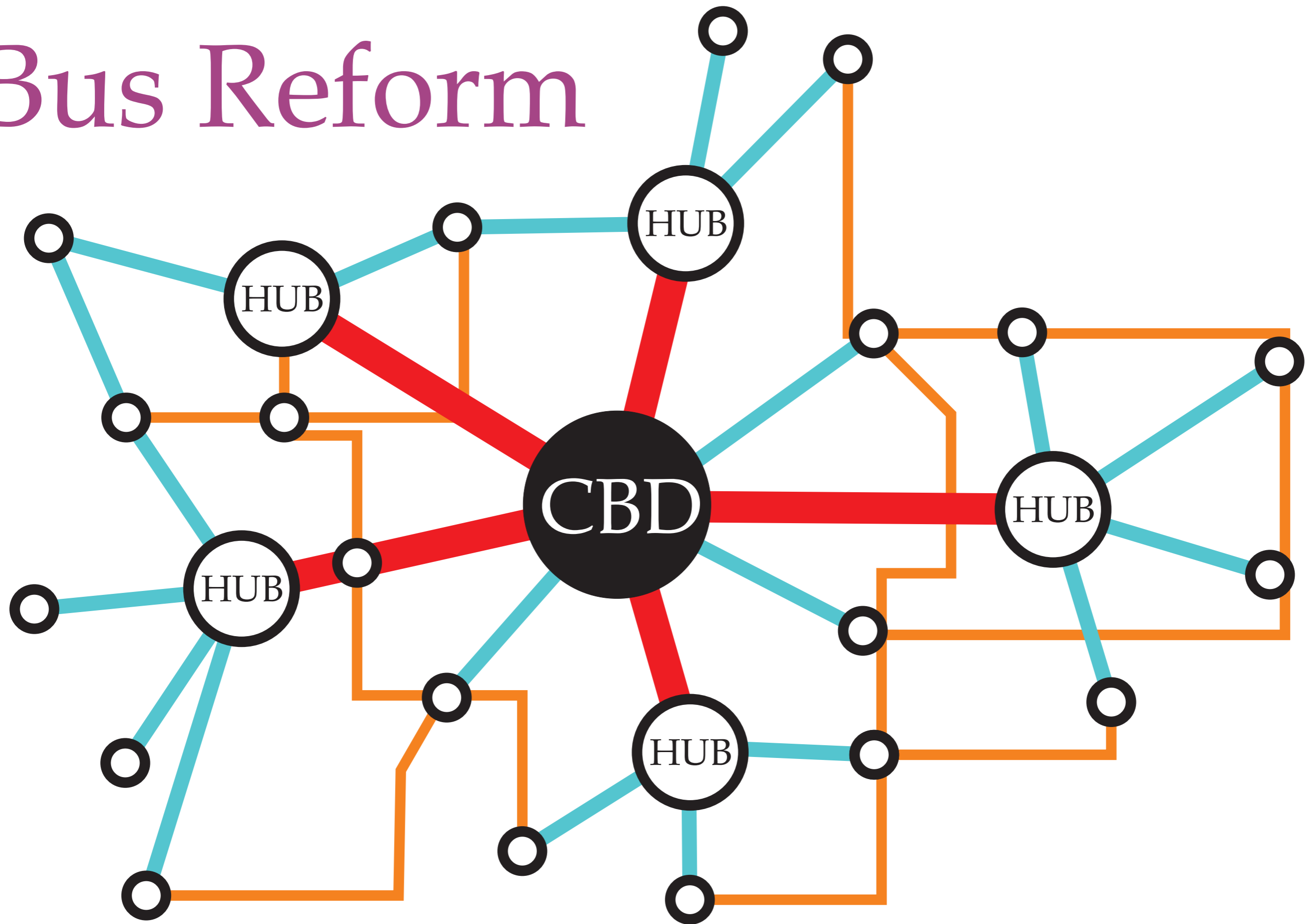

Brisbane Bus Issues

Same issues across the city.

Combined with realities of the cost of running a route as discussed equals.....

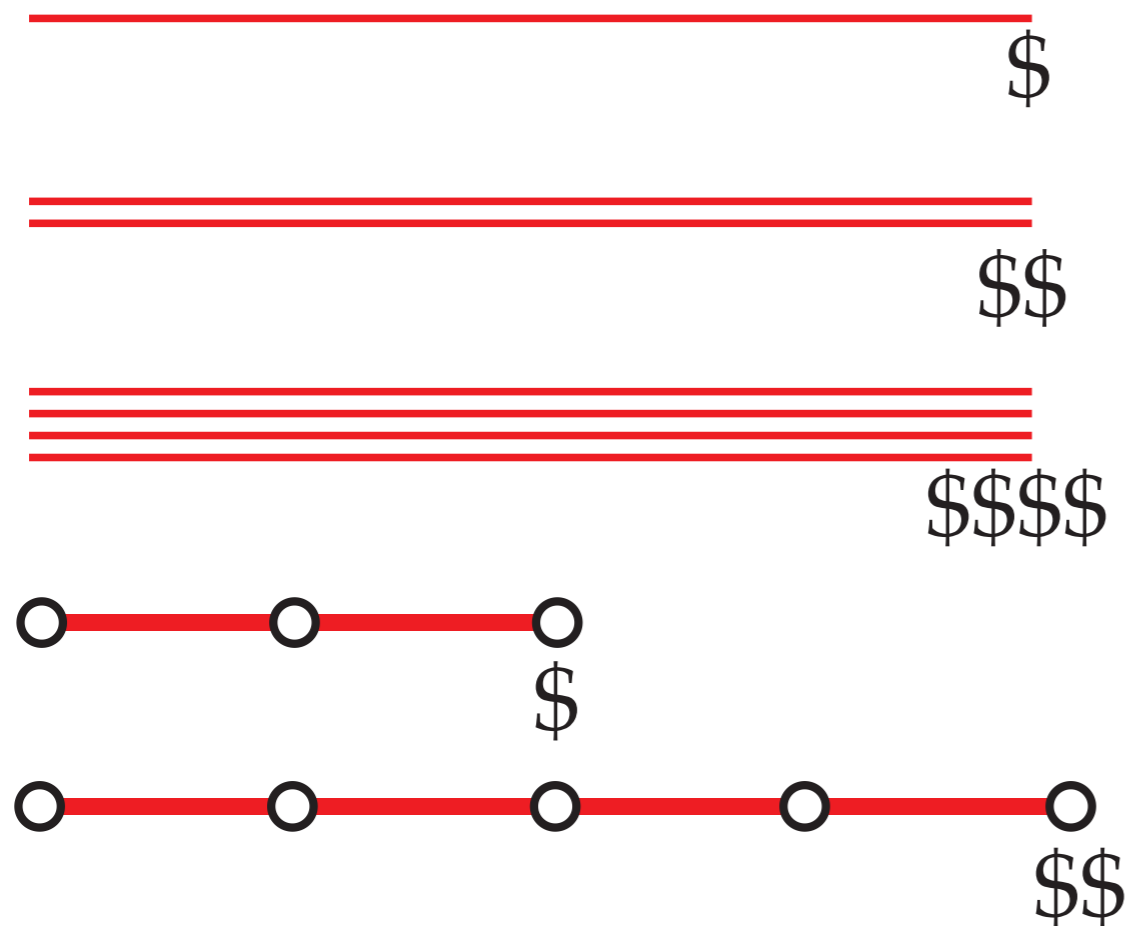

Bus Reform: Principle

- Stop Running *all* routes *all* the way to the CBD.
- “Fold Back” routes at suburban hubs/stations.
- A shorter route can run at higher frequency for same cost.
- Passengers from quieter routes combine to fill a larger bus/train. One driver = cheaper to run.

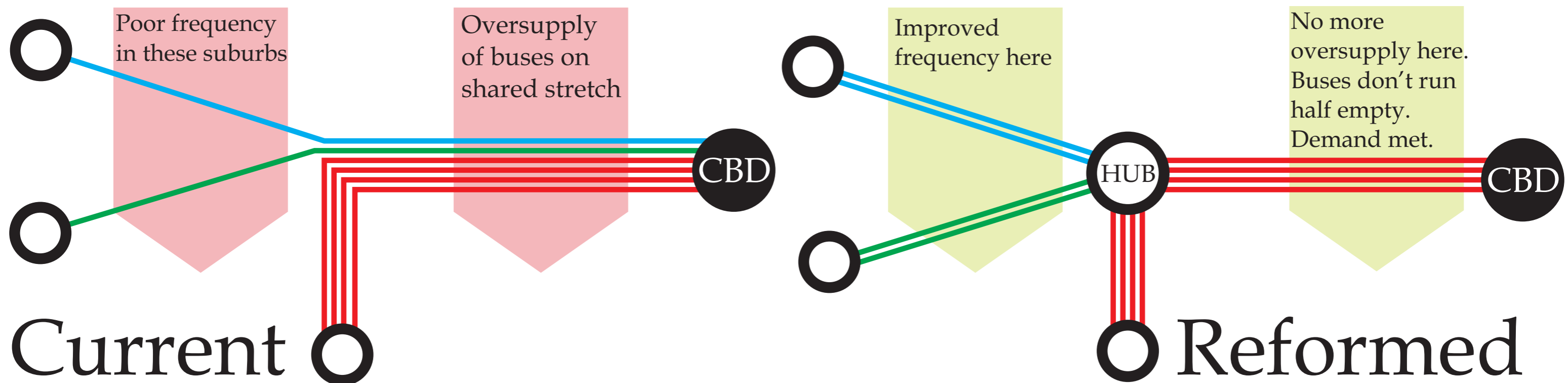

Connected network.

Deploying our transport resources so they work together rather than compete.



Connected network.

Interchange and connections.

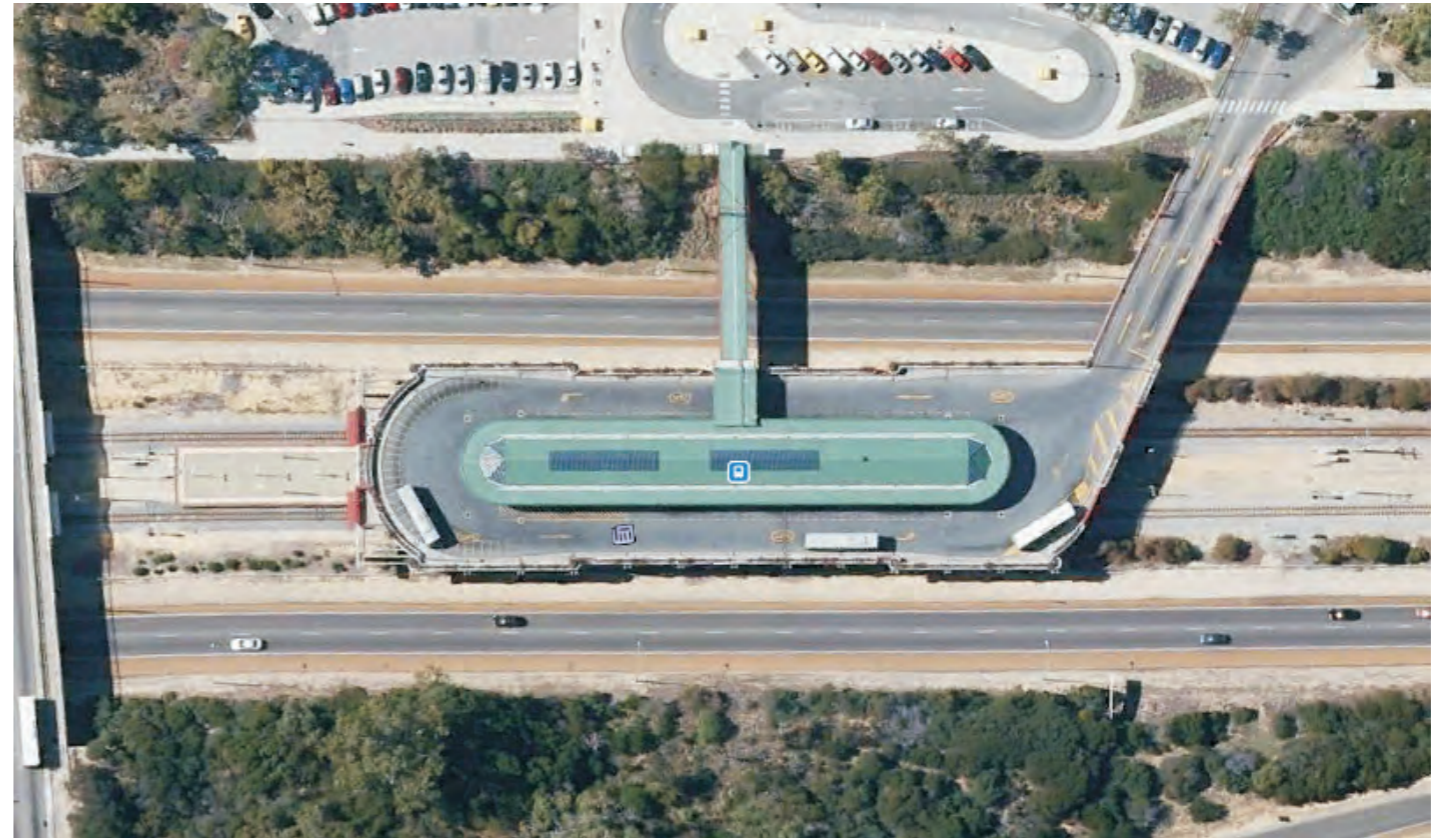

Connected network.

T Frequent Transit Network in Metro Vancouver

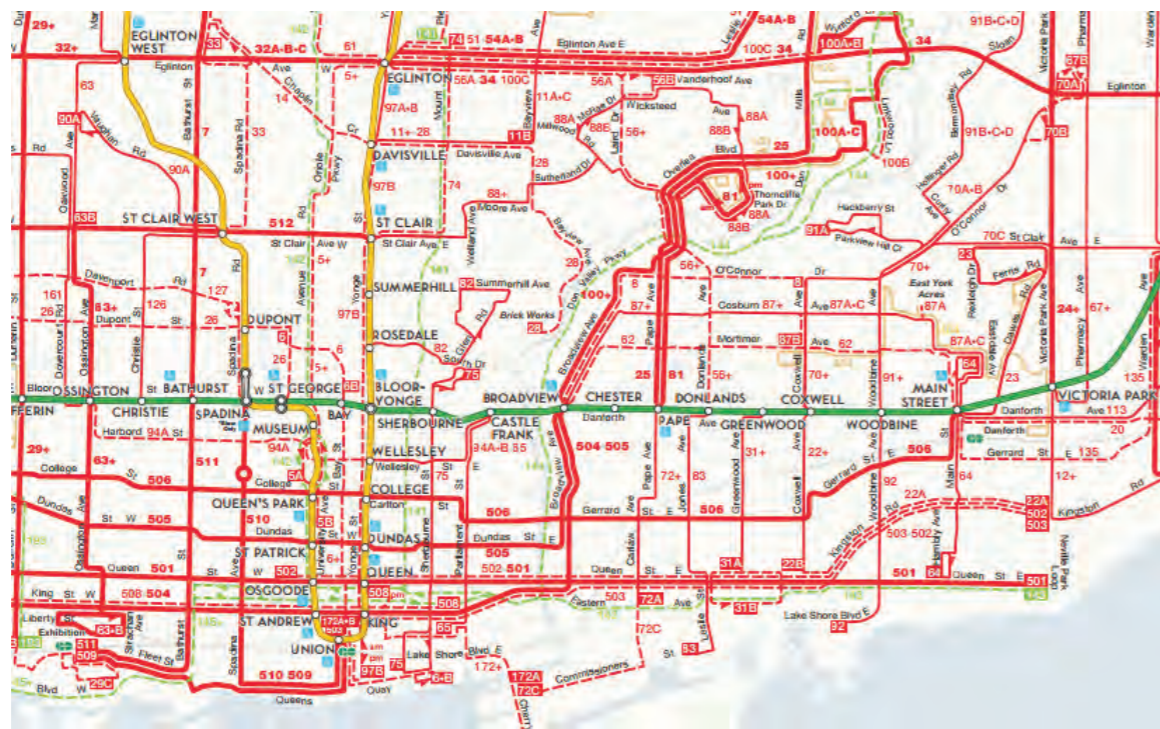
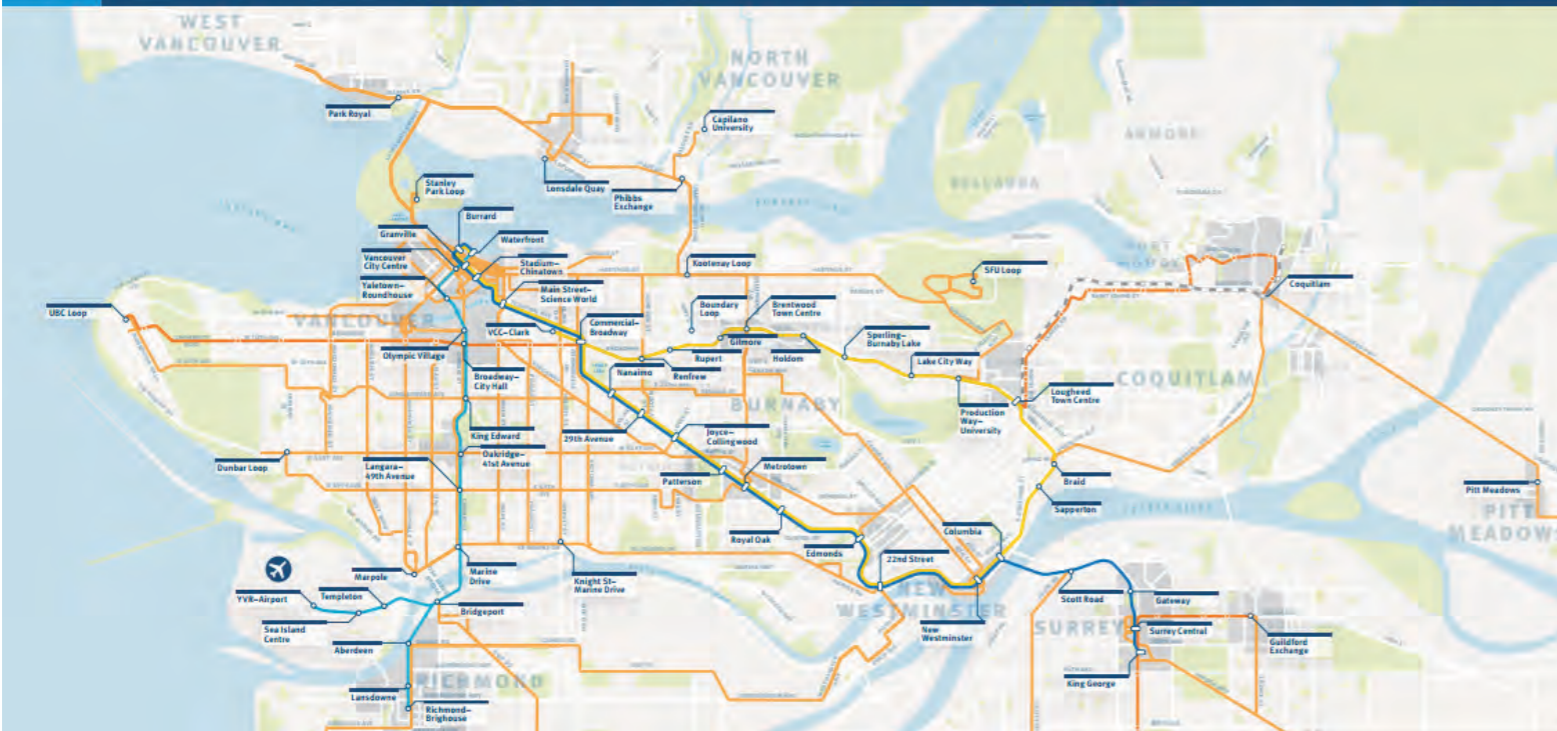

It's how the rest of the world does it....