



**Railway  
Gazette**  
INTERNATIONAL

# Rail conquers the Alps

Glasses will be raised in Switzerland on June 1 as the country celebrates the opening of the Gotthard Base Tunnel. *Railway Gazette International* is marking the occasion with this special feature compiled by **Murray Hughes**, and an accompanying e-book looking back over the history of the project. The Tunnel forms the centrepiece of the Swiss government's policy to switch transit freight from road to rail, but further measures are needed if the target of reducing the number of lorries passing through the Swiss Alps is to be met. In the meantime, Swiss voters have opted to build a second Gotthard motorway tunnel ... the story is far from over.



# National festival will mark Base Tunnel opening

Night falls on the Gotthard main line at Göschenen; from December most north-south through traffic will be routed via the Base Tunnel.

Photo: Lorenz Degen

No fewer than 17 years have passed since the first rock blast marked the start of work on the main bores of the Gotthard Base Tunnel. Surpassing Japan's 53.9 km Seikan tunnel by more than 3 km, the GBT ranks as the world's longest railway tunnel, and the Swiss are determined to celebrate this achievement in grand style. The opening ceremonies will take place on June 1, and the organisers have promised an 'unforgettable national festival' geared around a ceremony that will highlight 'the Swiss values of innovation, precision and reliability'.

Events will be staged at several locations. Special trains and shuttle buses will convey guests to ceremonies near the northern portal at Rynächt and the southern portal at Pollegio. After a media event in Castione-Arbedo near Bellinzona, the official programme begins at 12.00 with speeches by Federal President Johann Schneider-Ammann at Rynächt and Federal Transport Minister Doris Leuthard at Pollegio. These will be followed by the GBT receiving an official blessing before the opening trains run through.

A draw for 500 tickets to ride on the opening trains was arranged at the end of December 2015, and by the time applications closed at the end of January more than 160,000 requests had been received. Only Swiss nationals were qualified to apply, but each ticket was valid for two people. The lucky winners will be joined by two school classes chosen from those who had recently visited SBB's school experience train. The first

opening train is scheduled to depart from Arth-Goldau at 11.30 for Bellinzona, with the northbound special leaving Bellinzona at 11.45 for Luzern.

Guests invited to the opening will be able to take part in a series of activities that include watching a GBT rescue train in operation and visits to the maintenance and emergency control centres in Erstfeld and Biasca. Several cultural and musical events are planned, together with an exhibition by Swiss artists.

Perhaps the most important event of the day will be the formal handover of the Base Tunnel. Contractor AlpTransit Gotthard AG will present the structure to the Swiss government, which will then hand it to the operator, Swiss Federal Railways. SBB will have six months to carry out its own tests and to train and familiarise staff with procedures before regular commercial services start with the December timetable change.

Before that, however, the public will have an opportunity to ride through the GBT over the weekend of June 4-5. A shuttle service is planned, with trains running at up to 200 km/h. Four sites have been prepared to host parties in Erstfeld and Pollegio/Biasca — up to 100,000 visitors are expected.

After that SBB will run a special *Gottardino* service from August 2 until November 27 on Tuesdays to Sundays between Flüelen and Biasca with a special stop at the Sedrun multifunction station. Tickets priced at SFr119 in second class or SFr139 in first class are valid for a return trip via the old Gotthard route with its famous spiral curves. ■

**Murray Hughes** previews the opening events and celebrations commemorating completion of the Gotthard Base Tunnel.

## Looking back

### The Gotthard Base Tunnel in *Railway Gazette International*

World's longest rail tunnel will take traffic from road	RG 12.01 p841
57 km breakthrough	RG 11.10 p14
Banishing the Alpine barrier	RG 7.11 p31
The Gotthard Base Tunnel has a European dimension	RG 7.11 p32
How Switzerland has financed the Gotthard Base Tunnel	RG 7.11 p34
Eleven years to pierce the Alps	RG 7.11 p36
Speed and capacity define tunnel fit-out	RG 7.11 p40
Precision laying of low-maintenance track	RG 7.11 p44
Safety takes centre stage	RG 7.11 p46
Ceneri Base Tunnel completes high-capacity corridor	RG 7.11 p48
Railway works start at the north portal	RG 10.11 p75
Is Switzerland's transit freight policy working?	RG 6.13 p56
Ceneri Base Tunnel railway systems contract awarded	RG 9.13 p18
First test train in the GBT	RG 1.14 p16
220 km/h in the Gotthard Base Tunnel	RG 5.14 p26
Stadler wins high speed train contract	RG 6.14 p12
Golden sleeper	RG 12.14 p7
Gotthard Base Tunnel completes LVT installation	RG 1.15 p40
SBB's Tunnel preparations	RG 6.15 p29
Longest tunnel will transform traffic flows	RG 8.15 p46
Coping with the maintenance challenge	RG 8.15 p48
Freight targets may not be met	RG 8.15 p49
Level 2 on the Gotthard corridor	RG 9.15 p30

These articles and news reports are all included in our commemorative e-book, which can be purchased through the Railway Gazette App. For more details visit [www.railwaygazette.com](http://www.railwaygazette.com)



# We did it!

114 track-km in twin-bore tunnel, including plain line and switches, fully reprofiled in one single operation.

**SPENO INTERNATIONAL**  
speno.ch





# World's longest rail tunnel forges closer European links



In June Switzerland will celebrate completion of the Gotthard Base Tunnel, marking a major milestone in the national strategy to switch transit freight from road to rail.

## DR PETER FÜGLISTALER

Director  
Swiss Federal Office for Transport

**A**t the end of February 2016 the Swiss electorate voted in a referendum in favour of building a second Gotthard road tunnel. Located at the heart of Switzerland's most important trans-Alpine corridor, this is expected to open around 2030, and I stand very firmly behind the electorate's choice.

The decision means that road safety on this transit corridor will be enhanced and, taken with refurbishment of the existing road tunnel, it represents a long-term investment. This is



Modern and efficient. The Gotthard Base Tunnel awaits its first commercial traffic.

a reasonable and sensible decision that will ensure safety is brought up to the latest standards.

It is equally important to note that the vote does not provide additional capacity for private cars and lorries on the Gotthard corridor. After completion of the second bore, there will still be only one lane of traffic in each direction, as there currently is in the existing road tunnel. This principle is enshrined in law and cannot be easily overturned. This is because Switzerland is committed to a policy of transferring trans-Alpine road traffic to rail.

Affirmation of this policy is evident with the entry into service at the end of this year — following the opening

celebrations in June — of the world's longest railway tunnel: the Gotthard Base Tunnel. This remarkable 57 km tunnel will bring marked improvements to rail traffic on Switzerland's most important north-south transit route, making rail significantly more attractive compared with the situation up to now. In contrast to the future road tunnel, the Base Tunnel will not just improve safety but will add extra capacity and enhance the quality of service.

## Shorter journey times

Once the Ceneri Base Tunnel and improvement works on the approach routes have been completed around 2020, journey times for passenger trains between north and south Switzerland will be cut by around 45 min. A trip from Zürich to Milano will in future take just 3 h.

Freight traffic will benefit from infrastructure that is far more modern and efficient than today's railway — the new tunnel will form a low-level route through the heart of the Alps. This means that a single locomotive will suffice to haul long freight trains through the mountains; no longer will it be necessary to add a banker to help trains negotiate the steep gradients of the existing line.

Not only that, but the Base Tunnel will trim 30 km off the length of the journey via the old line. Whereas the number of freight train paths over the old line was limited to 180 a day, there will in future be 260 paths a day available.

Closely related to the Base Tunnel project is upgrading of the approach routes in Switzerland and Italy — by 2020 the whole of this major north-south rail corridor will be able to accept rail wagons carrying 4 m high lorries.

These impressive advances mean that the Gotthard Base Tunnel will become the key element at the core of the European Rhine-Alps rail freight corridor. This links the northern ports of Rotterdam and Antwerpen with the metropolitan cities of northern Italy and the port of Genova, passing through Germany's industrial heartland in the Ruhr and through Switzerland. So we have built this magnificent tunnel not just in our own national interest, but also in the interest of Europe. The Gotthard Base Tunnel is a contribution



# Message **GOTTHARD BASE TUNNEL**

that Switzerland is making to the integration, economic inter-dependence and wellbeing of our continent.

Of course, we have not made this gift to Europe without a degree of self-interest. The Swiss electorate voted in referenda in 1992 and 1998 in favour of two new railway base tunnels, not least because switching trans-Alpine freight from road to rail was a major objective dear to the Swiss psyche. The first of the two, the Lötschberg Base Tunnel, was successfully opened in 2007.

### Rail's high market share

With the measures taken so far, Switzerland has succeeded, despite continuous economic growth, in reducing the number of lorries and semi-trailers passing through the Swiss Alps from 1.4 million a year in 2000 to about 1 million. Rail's share of the transit freight market is now nearly 70%.

In addition to opening the Gotthard Base Tunnel to commercial traffic and upgrading of the Gotthard transit route for 4 m high lorries on rail, Switzerland is planning further measures to drive traffic from road to rail. From 2017 the



Photos: Alptransit Gotthard

*Leistungsabhängige Schwerverkehrsabgabe* lorry transit fee between the northern and southern borders will rise from around €250 per trip to about €270. Not only that, but the Swiss government will adjust the track access fees for trans-Alpine routes in 2017-21 so that pricing encourages the use of long and heavy freight trains.

We expect our foreign partners to use this new, modern rail tunnel to ship their goods. The European Commission

Through the heart of the Alps. A test train at the northern portal of the Gotthard Base Tunnel near Erstfeld.

made a commitment in its 2011 White Paper to a forward-looking and environmentally-friendly policy for long-distance freight. And we hope that further steps in this direction will follow. Our European partners can also make a contribution by timely upgrading of their rail approach routes in northern Italy and southern Germany, so ensuring that the Gotthard Base Tunnel is a success story not just for Switzerland, but also for Europe. ■

## We are a part of it with our quality products for modern overhead contact lines

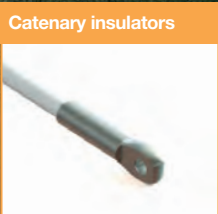

**Arthur Flury AG**  
 CH-4543 Deitingen/Switzerland  
 Tel. +41 32 613 33 66 info@af.flury.ch  
 Fax +41 32 613 33 68 www.af.flury.ch

## GOTTHARD BASE TUNNEL Project



# A masterpiece of engineering

DR SC TECHN DIPL BAUINGENIEUR ETH  
RENZO SIMONI

Chief Executive Officer  
AlpTransit Gotthard AG



After 17 years of construction, the Gotthard Base Tunnel will be ceremonially opened on June 1 2016. Its 57 km length accords it the title of longest railway tunnel in the world, but the Base Tunnel also deserves recognition as a true masterpiece of engineering.

Stretching from a north portal near Erstfeld in the Canton of Uri to the south portal near Bodio in the Canton of Ticino, the Base Tunnel consists of two single track bores that lie

**Testing times.** Following this first test train speeds were gradually ramped up during a series of trials towards the end of 2015.

History will be made on June 1 when the Gotthard Base Tunnel is formally opened and contractor AlpTransit Gotthard AG hands the record-breaking twin-bore structure over to Swiss Federal Railways.

about 40 m apart. Cross-passages link the two running tunnels at intervals of 325 m. If all access galleries, adits and shafts are taken together, the total length of tunnel amounts to 152 km.

The rock overburden rises to 2300 m, making it the world's deepest rail tunnel. Another characteristic is that there are no steep gradients — the tunnel's summit lies 550 m above sea level, and the steepest grade facing a train is just 1.25%.

Two multi-function stations located

beneath the settlements of Faido and Sedrun divide the tunnel into three roughly equal sections (Fig 1). Trains can switch from one running tunnel to the other in both stations, where there are facilities for dealing with trains halted in an emergency.

### Construction

Construction of the GBT was split into five sections. To ensure the best use of time and money, the construction programme for the different sections





# Project GOTTHARD BASE TUNNEL

**Making tracks.** The booted sleepers of the GBT's ballastless track await the final pour of concrete at this site near Erstfeld.

was carefully co-ordinated, with some work taking place simultaneously.

The tunnellers had to cut through several different types of rock that ranged from hard granite to heavily fragmented sedimentary strata. About 80% of the main running tunnels were driven using tunnel boring machines, the other 20% requiring the use of conventional blasting techniques. A total of 28.2 million tonnes of spoil was excavated and moved out of the tunnel for disposal or reuse. Deep underground the tunnellers experienced temperatures as high as 45°C, and at peak construction times as many as 2 400 people were working at the same time. Three shifts a day ensured that work continued round the clock.

Despite a few surprises, the



Photos: AlpTransit Gotthard Ltd

**Right: Fit-out.** The narrow-gauge construction railway is still in place as fitting out progresses in the Amsteg section.

geologists' forecasts about the types and condition of the rock proved to be largely correct. One of the areas considered to have the highest risk was in the north drive of the Sedrun section through the intermediate Tavetsch massif, but careful choice of construction methods on this section ensured that the work proceeded without serious problems.

Tunnelling through the Piora zone, which was thought to consist of 'sugar dolomite' that would be almost impossible to deal with, turned out not to be a problem. All the debate that took place at the start of the planning process evaporated after a trial bore was excavated, confirming that the rock formation was after all not an insuperable barrier.

On the other hand, the geologists had expected the Faido multi-function station to be located within a layer of gneiss that favoured construction, but during excavation of the access gallery it became clear that a large area of broken rock under pressure occupied the middle of the planned station site. This led to a decision to move the station cavern about 600 m further south, incurring penalties in terms of time and cost.

On October 15 2010 the miners celebrated the achievement of a world record tunnel length when the breakthrough took place at a spot 30 km in from the south portal and 27 km from the north portal. The surveyors also had cause to celebrate: the difference in alignment between the two halves of the tunnel was just 80 mm horizontally and a mere 10 mm vertically. The miners continued their work until the final breakthrough which occurred 11 years after the start of tunnelling.



The first breakthrough of a running tunnel took place on October 15 2010.



# GOTTHARD BASE TUNNEL Project



Green light. Cross-passages between the two running tunnels are located at 325 m intervals. They are identified by green doors and are designed to be used as escape routes in an emergency.

## From tunnel to railway

The breakthroughs were important milestones, but the job was far from over. The next task was to complete the linings in both running tunnels. After that specialist teams entered the tunnel to install a range of electrical and mechanical equipment that included doors, drainage and ventilation plant — all essential to ensure that the tunnel could be operated and maintained safely.

Installation of railway equipment began in 2010 — it was a five-year job. Building a railway inside the tunnel was a complicated and demanding task — track, power supply equipment, telecommunications and safety installations all had to be fitted. Good co-ordination between the civil engineers who had built and lined the tunnel and the railway equipment specialists was critical, as was the need for a flexible plan. Not only that, but access was only possible through the portals at each end.

That fact, the long distances and the confined space meant that logistics were crucial. As road vehicles could not turn round inside the tunnel, almost all the railway equipment had to be moved in by train. The track therefore had to be laid during the initial phase of work; only after the track was in place could the other equipment be installed.

Installation of railway equipment in the different sections was carried out



Photo: AlpTransit Gotthard Ltd

Simulation. A full-scale emergency rescue exercise involving 800 people was staged on March 19. A fire alarm was activated on an ICN trainset after it had entered the eastern running tunnel from the north portal.



Photo: SBB

Fig 1. The Gotthard Base Tunnel is divided into three roughly equal sections by two multi-function stations where trains can switch from one bore to the other.

in stages. In 2010-11 the western running tunnel in the Bodio section was fitted out from a railway equipment worksite located at Biasca. This was

followed by installation from a similar worksite at Erstfeld at the northern end, allowing equipment of the eastern and western running tunnels as far as Faiedo. Finally, in 2014, railway equipment was fitted in the eastern tunnel of the Bodio section.

Last of all, the tracks in the tunnel had to be linked to the existing Gotthard main line. From the northern portal around 5 km of new railway had to be built, while in the south the link stretched for 7 km. In both cases the work entailed building overbridges and underbridges.

## Commissioning

Commissioning a huge structure like the GBT is a complex task that needs to be tackled in stages. Before any timetabled trains can pass through it is essential to thoroughly check and test all the tunnel equipment. A programme of checking, test running and staff training began on October 1 2015. This was a huge task as around 3 500 test runs were required.

The first stage was to undertake detailed checks to determine if

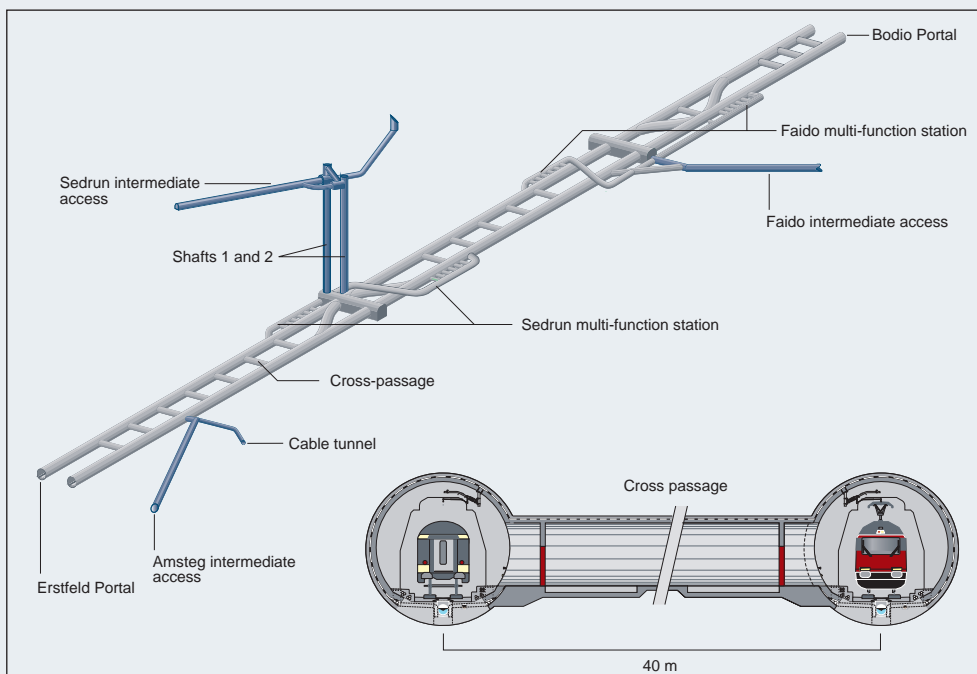





# Project GOTTHARD BASE TUNNEL



Photo: AlpTransit Gotthard Ltd

**Open and shut.** Mobile doors mounted on special wagons will seal the tunnel at specific locations to avoid pressure changes and to ensure good air quality when maintenance work is in progress.

In the period from October 2015 until January 2016 the test programme focused on simulation of operations in normal and degraded conditions with various incidents being staged. This process reached a climax on January 25-26 in the so-called Big Test in which eight trains were involved in a series of incidents at the same time.

On February 6 2016 tests were undertaken with a 1 500 m long freight train. This consisted of 76 wagons of different types; flat wagons, vans with telescopic sliding roofs and empty container wagons. Weighing 2 216 tonnes, the train was hauled by three Type Re620 locomotives, one at each end and one marshalled in mid-train. Various runs were made to determine if such a long train could operate satisfactorily through the GBT using ETCS Level 2.

### Trial running

SBB is responsible for the trial runs, which are geared to implementation of the various operating procedures in different situations and in realistic conditions. They are also designed to test the arrangements for operations, interventions and maintenance, starting with

detailed checks to determine if individual components and installations functioned correctly. It was then necessary to check that all the components interacted correctly with the tunnel control technology. Only then could the 'bedding-in' process start. For some operational equipment it was possible to complete the tests during installation.

Soon after the first test run on October 1 2015 a series of trials began using ETCS Level 2, which has been installed through the GBT and on the approach routes. The tunnel radio and the digital GSM-R radio system were in the meantime checked by SBB's radio test train.

In November and December 2015 a series of high speed tests was carried out. The maximum speed was progressively raised, culminating in a peak figure of 275 km/h. This maximum was achieved for the first time during a trial run through the eastern running tunnel on the night of November 8-9 using the ICE-S train on hire from Germany.

High speed trials in the Gotthard Base Tunnel were conducted during November and December 2015 using the ICE-S test train on hire from Deutsche Bahn. This set a new Swiss record when it 274.5 km/h at 02.15 on November 17 2015 (right).



Photos: AlpTransit Gotthard Ltd

# GOTTHARD BASE TUNNEL Project

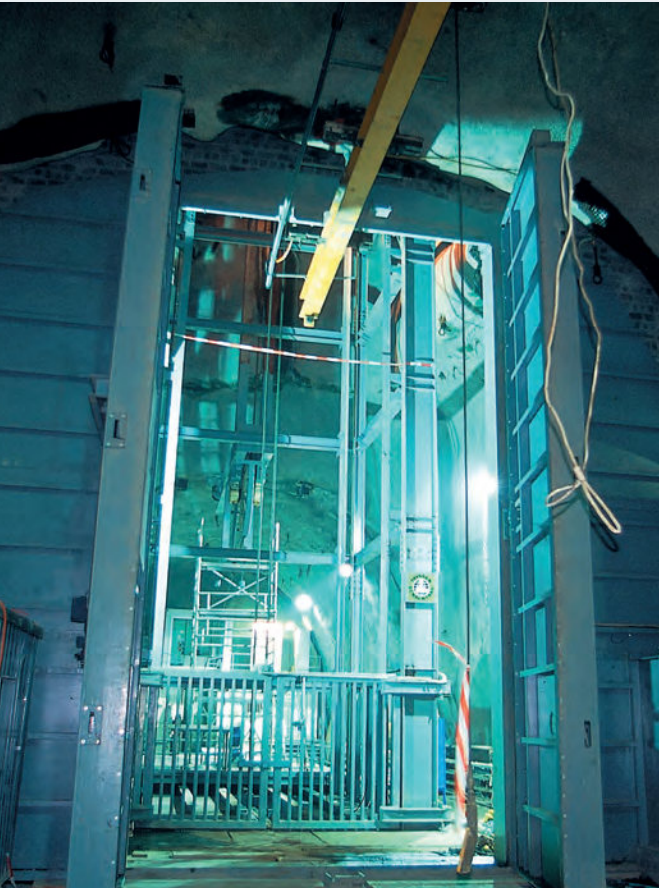

Photo: AlpTransit Gotthard Ltd



Photo: SBB

**Machine room.** Ventilation, drainage and pumping equipment is located in sealed rooms inside the tunnel.

maintenance operations and trial runs. The phase using commercial services will gradually work up to a stress test with a large number of freight trains involved. From August to November there will be further stress tests using passenger trains.

### Operating concept

In contrast to many high speed lines which are designed exclusively for passenger trains, the GBT is designed to accept passenger trains running at up to 250 km/h as well as freight trains travelling at 110 km/h. This affects the design of the safety installations, but it is also a factor that determines

maximum capacity.

In the initial operating phase there will be paths for five freight trains and two passenger trains per hour in each direction. One of the operating principles is that no maintenance will be carried out when commercial services are running. This means that regular maintenance has to be carried out at night.

All tests, including the stress tests and those needed to obtain the various approvals and authorisations, are currently on target for opening to commercial traffic in December 2016. Then, finally, the GBT will carry its first regular timetabled commercial services. ■

**Stress testing.** Some commercial freight trains will be routed through the tunnel as testing and commissioning progresses, with several services passing through at the same time.

complicated and demanding events.

To ensure that SBB could take on the primary responsibility for trial running from the outset, some trials had to be carried out in the test phase when AlpTransit Gotthard was still responsible for the GBT (Fig 2). These included rescue operations and trials to train the maintenance organisation.

During this phase the trials are being switched from pure tests to simulated operations with regular train services. This transition process includes training trips using commercial services as the different phases of testing are ramped up.

Essentially, there are three groups of tests: commercial operations,

**In at the deep end.** Two 800 m shafts were sunk to reach the tunnel alignment at Sedrun.

**Fig 2.** The commissioning process involved checking every component to ensure that it functioned correctly.



Photo: SBB

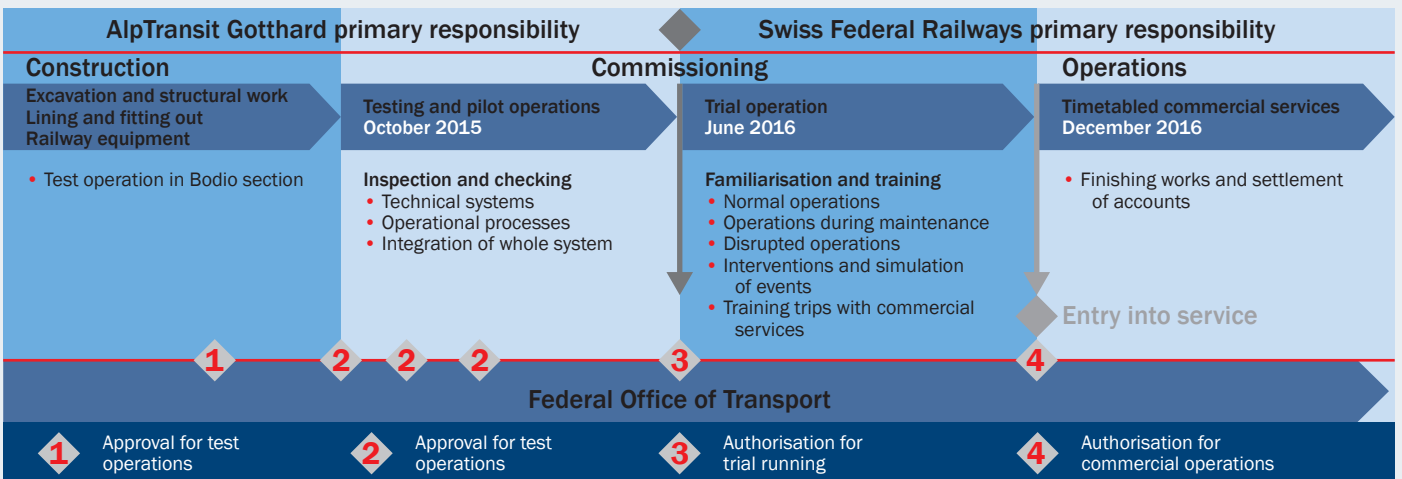

# ADVERTISEMENT



## Gotthard Base Tunnel We make it possible for trains to travel through the longest rail tunnel in the world

When the official opening ceremony of the Gotthard Base Tunnel (GBT) takes place on the 1st of June, Kummeler+Matter (KuMa) will also have something extraordinary to celebrate: the successful planning and realisation of catenary technology as part of the railway installations

for a project of the century. The Alpiq subsidiary KuMa, together with its consortium partner BBR, realised the entire traction current plant for both 57-kilometre long single-track tubes in the longest railway tunnel in the world, and for the approach lines outside the tunnel.

### About Kummeler+Matter

For over 100 years, the services provided by Kummeler+Matter have ensured the reliability of electrical installations in the infrastructure sector. The customer can rely on us, whether it's for the transmission of electrical power, telecommunications, catenary and rail safety engineering or traffic control systems. Read more at: [www.kuma.ch](http://www.kuma.ch)

### Complex processes — logistical feats

Installing the traction current plant was a complex process. It involved twelve operations, from the measuring of the support bases to the installation of the traction power supply. Each operation was completed separately. The overhead contact line, a catenary system Type Re250 GBT, consists of the catenary (contact wire and supporting cable) with four parallel feeders for the tunnel section.

The overhead contact line developed specially for the Gotthard Base Tunnel offers the ideal solution for the power supply of heavy freight trains and the navigability of passenger trains travelling up to 250 km/h. The individual components were assembled in several operational steps to make the entire system, from setting the anchor rods to installing the power connections.



## Innovative and high quality Catenary Solutions for the longest rail tunnel in the world

Reliability, quality, flexibility and professionalism are the core values for all our railway engineering projects.

Our comprehensive products and services in the new **Gotthard Base Tunnel**:

- Planning
- Catenary material
- Assembly
- Maintenance

Kummeler+Matter Ltd.  
Hohlstrasse 188  
CH-8004 Zurich  
T +41 44 247 47 47  
F +41 44 247 47 77  
[info.zuerich@kuma.ch](mailto:info.zuerich@kuma.ch)  
[kuma.ch](http://kuma.ch)



A COMPANY OF THE GROUP ALPIQ



# North-south corridor upgraded by 2020

Work to enlarge or duplicate about 20 tunnels is needed to ensure that intermodal trains can carry 4 m high lorries through Switzerland.



Photo: SBB

Completion of the Gotthard Base Tunnel is the biggest single element in the Swiss programme to transform its principal north-south railway into a high-performance transit corridor. The over-riding objective is for rail to become the primary mode for freight passing through between Germany and Italy.

While much transit cargo travels in block trains or as wagonload traffic, a significant share is carried on intermodal trains, either in containers or in semitrailers carried on rail wagons. Semitrailers are increasingly built to a height of 4 m, and this already applies to 60% of lorries passing through the Swiss Alps, according to the Federal Office for Transport, which expects the proportion to rise further over the next few years.

Whereas the Gotthard Base Tunnel was designed from the outset to accommodate 4 m high lorries, the approach routes to north and south are characterised by historic structures that do not provide sufficient clearance. The original intention had been to upgrade the whole route to coincide with opening of the GBT, but in the event a decision to enlarge clearances along the north-south corridor was postponed. In any case, the Ceneri Base Tunnel (p66) will not open until 2020.

Once it became clear that larger clearances were essential if the government were to achieve its policy objective of switching transit freight to rail, action was needed. On June 1 2014 the government passed a law obliging Swiss Federal Railways to adapt the approach routes to accept wagons conveying 4 m high semitrailers. This led to the signature of an agreement with SBB on October 8 that

**More space needed.** Work on a second Bözberg tunnel to obtain larger clearances on Switzerland's busiest north-south transit corridor began on March 9.

year which sets out the details, timescale and finance — a dedicated credit worth SFr630m has been earmarked for the work. A further SFr194m is available under the terms of the government's performance contract with SBB.

The resulting corridor will stretch from Basel in the north to the Italian border crossings at Chiasso on the main line from Bellinzona to Milano and at Ranzo on the route from Giubiasco to Luino; completion of the work is expected by December 2020.

## Duplicate tunnels

Around 80 individual gauge enhancement projects are needed to achieve the required clearances. The biggest single scheme is construction of a second Bözberg tunnel in the canton of Aargau, where a groundbreaking ceremony was held at Schinznach-Dorf on March 9 (RG 4.16 p10); preparatory works had begun in October 2015. The 2.7 km double-track bore will run parallel to the existing tunnel, which will be modified by 2022 to provide access through cross-passages for maintenance and emergency services. Studies had shown that attempting to rebuild the 140-year old structure

would be more expensive than building a new tunnel. Breakthrough for the new bore is expected by the end of 2017.

Around 20 other tunnels are being enlarged or adapted (Table I). These include three more new tunnels, two of which are single track and which will not be commissioned until 2022-23. Work to improve the Maroggia and Paradiso tunnels is particularly time critical.

Elsewhere, alterations to bridges, signals, platform roofs and electrification equipment are required in about 150 locations.

Some work is also being undertaken on parts of the old line, for example between Giubiasco and Vezia, but this is less time-critical and will not be started until after 2020.

All this work means that some disruption to existing services is inevitable until the programme is finished in 2020. From that date trains carrying 4 m high lorries will be able to run through Switzerland without hindrance.

## Italian routes

In conjunction with the gauge improvement work within its own borders, Switzerland has agreed to fund similar enhancements in northern Italy. This will ensure that intermodal trains can continue to terminals in or near Milano such as Busto Arsizio.

Under an agreement signed by the transport ministers of the two countries on January 28 2014, a total of €120m is being made available to Italian infrastructure manager RFI for work on the line via Luino, while the Italian government is providing €40m for works between Chiasso and Milano. ■

Table I. Basel – Chiasso corridor upgrading

Project	Scope of work	Completion	Cost SFr m
1 Bözberg tunnel	New double-track bore, refurbishment of old bore	2020	348
2 Villnachem tunnel	Widening	2019-20	10
3 Rindelflüh tunnel (I and II)	Loading gauge enhancement	2015	6
4 Morschacher tunnel	Widening	2018	5
5 Axentunnel Seegleis	Loading gauge enhancement	2019	123
6 Crocetto and Giustizia tunnels	Enlargement	2015-16	26
7a Svitto tunnel I	Widening	2017-18	36
7b Svitto tunnel II	New single-track tunnel	2022-23	36
8a Dragonato tunnel I	New double-track tunnel	2017-18	13
8b Dragonato tunnel II	New single-track tunnel	2022-23	10
9 Massagno tunnel I and II	Loading gauge enhancement	2012-13	7
10 Paradiso and San Martino tunnels	Widening	2020	66
11 Maroggia tunnel	Widening	2020	49
12 Molino tunnel	Widening	2020	6
13 Coldrerio tunnel	Widening	2020	12
14 Balerna tunnel	Loading gauge enhancement	2016	6
Costa and Molincero tunnels, Ceneri old line	Widening	2020	10
Other works	Various	2020	25
Project management	-	-	30
<b>Total</b>			<b>824</b>

Fig 1. Around 20 tunnels are being enlarged or altered to accommodate high lorries on rail wagons along the busy corridor between Basel and the Italian border.



# Transit routes GOTTHARD BASE TUNNEL

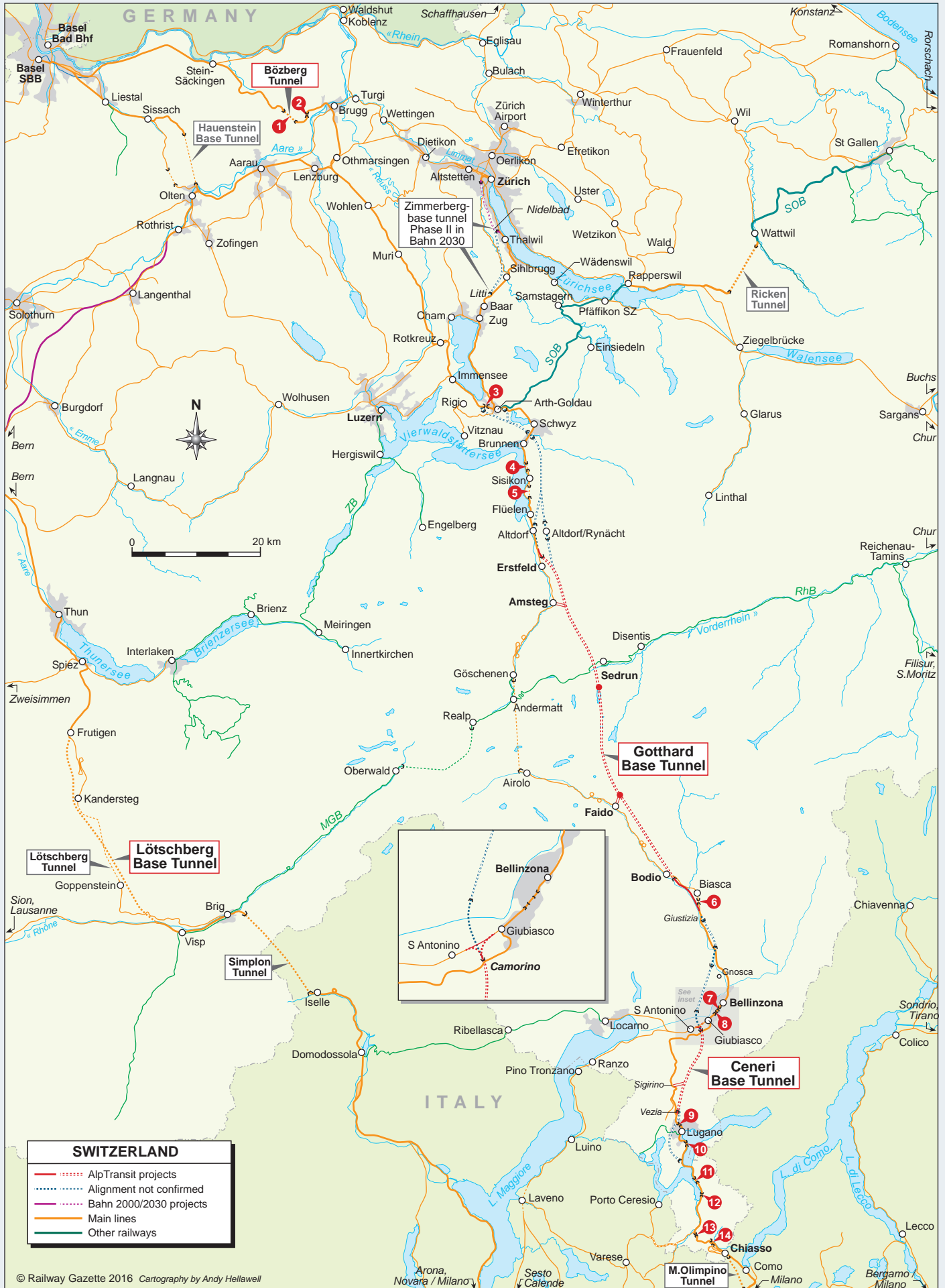

# GOTTHARD BASE TUNNEL Corridor



Photos: Alp Transit Gotthard Ltd

The final breakthrough for the western bore of the Ceneri Base Tunnel took place on January 21 2016.

line running from west to south will be located in the tunnel, necessitating construction of a large cavern. At the moment passengers travelling between Lugano and Locarno have to change trains at Bellinzona, a trip taking about 55 min. Thanks to the new chord the journey will in future take just 22 min.

## Construction

Work began with excavation of a 3.1 km exploratory tunnel in 2007; this confirmed that the geology of the Ceneri massif was very complex, which meant that the main tunnels had to be excavated solely by drilling and blasting.

In 2008 a 2.3 km access gallery was cut from Sigirino using a TBM to provide an intermediate access route to the tunnel alignment, and it was from here that the main drives began using conventional blasting in 2009-10. Before that several large caverns had to be excavated to house the machinery needed for the main drives.

Further worksites were set up near the northern portal at Camorino near Vigana and near the southern portal at Vezia, but both sites had physical constraints that restricted the scale of work. In both locations nearby housing required the contractors to tailor working methods and equipment to limit noise and disturbance.

Dealing with large variations in the overburden was another challenge for the tunnellers. At its highest point the overburden reaches nearly 900 m, but in other locations it is just a few metres deep.

## Breakthroughs

The first breakthrough took place on March 17 2015 around 400 m away from the Vezia portal in the western running tunnel, followed by a similar event in the eastern bore on March 30. The final breakthrough in the western running tunnel was at midday on January 21

# Ceneri Base Tunnel on target

The final breakthrough for the Ceneri Base Tunnel in January paves the way for railway equipment installation to start next year.

**W**hile attention is focused on the opening of the Gotthard Base Tunnel, work continues at full speed on the Ceneri Base Tunnel at the southern end of the Gotthard corridor. Located between Giubiasco, just south of Bellinzona, and Lugano, the tunnel will provide a low-level alternative to the old line through Mezzovico and Taverne-Torricella which has gradients of up to 2.6%. At 15.4 km, it is considerably shorter than the Gotthard Base Tunnel, but it is being built to the same standards with two single track bores about 40 m apart linked by cross-passages at 325 m intervals; maximum speed is 250 km/h for passenger trains. There are no crossovers or emergency stations within the tunnel.

The design of the tunnel near the northern portal was complicated by the need to accommodate access tracks from both the Gotthard main line and

**Centre point.** Most of the Ceneri Base Tunnel was excavated from the intermediate construction site at Sigirino.

a new chord being built to allow trains to run directly between Lugano and the resort of Locarno on Lago Maggiore. This was requested by the Ticino canton, which is keen to improve local rail services. Part of the junction with this





# Corridor **GOTTHARD BASE TUNNEL**



**Going in.** The northern portal of the Ceneri Base Tunnel at Vigana has been completed.

2016 at a point located 700 m from the northern portal. The two tunnels proved to have been cut with considerable accuracy, the difference being just 20 mm horizontally and 10 mm vertically.

guests attended the event, which was marked by one section of the tunnel being transformed into a party zone with colourful lighting. AlpTransit Gotthard Chief Executive Officer Renzo Simoni thanked all those involved but

**Coming out.** Construction of the southern portal at Vezia was complicated by the presence of buildings very close to the alignment.

also recalled that two miners had lost their lives during construction. The final breakthrough in the eastern bore followed just five days later.

With both bores holed through, work is in hand to complete the tunnel lining. All adits and tubes will be lined and concreted by the end of this year, after which work will begin on installing doors, ventilation equipment and building management systems. The first railway equipment will be installed in summer 2017, with track, power supplies, train control and telecoms systems being progressively fitted in the two bores from a dedicated site with pre-assembly facilities at Camorino. The tunnel is due to be opened in December 2020.

Provision has been made at both ends of the Ceneri Base Tunnel for future extensions. At the northern end the line would form part of a bypass round Bellinzona, while at the southern end there may one day be an extension towards Chiasso. ■

“

*‘The two tunnels proved to have been cut with considerable accuracy, the difference being just 20 mm horizontally and 10 mm vertically’*





## GOTTHARD BASE TUNNEL Milestones

# Mountain milestones

The idea of a base tunnel through the Swiss Alps dates back to 1947. Here we chart the significant dates for the Gotthard Base Tunnel and the AlpTransit projects.

**May 22 1882**

Original Gotthard rail tunnel opens.

**1963**

A government committee is established to report on trans-Alpine rail tunnels.

**1971**

Bundesrat asks SBB to draw up plans for a Gotthard Base Tunnel from Erstfeld to Biasca; the work is completed in 1975.

**1986**

Further base tunnel studies are conducted.

**May 2 1992**

Switzerland signs agreement with the European Community committing the Alpine nation to provide a specified capacity for transit freight.

**September 1 1993**

SBB takes over the AlpTransit project organisation from the Federal Office for Transport.

**February 20 1994**

Referendum approves Alps Initiative and enshrines protection of the Alps in Swiss constitution.

**April 12 1994**

Work starts at Frutigen on test bore for Lötschberg Base Tunnel.

**1947**

Carl Eduard Gruner, an engineer and urban planner, outlines the concept of a Gotthard Base Tunnel.

**1970**

Another committee examines alternative routes for base tunnels, but political disagreements and recession halt progress.

**September 5 1980**

Gotthard motorway tunnel opens.

**1989**

After consulting the cantons, the Bundesrat decides on a package combining the Lötschberg Base Tunnel, the Gotthard Base Tunnel and a Hirzel tunnel forming a link to eastern Switzerland.

**September 27 1992**

Swiss referendum backs NEAT (AlpTransit) investment programme with 64% majority.

**October 4 1993**

Exploratory bore commences to determine the geology of the Piora zone, thought to be impossible to tunnel through, on the proposed alignment of the Gotthard Base Tunnel.

**April 12 1995**

Bundesrat accepts proposal from SBB for a twin-bore Gotthard Base Tunnel between Erstfeld and Bodio with two intermediate multi-function stations and a surface alignment from Bodio to Giustizia.

**December 14 2002**

First breakthrough of a running tunnel in the Lötschberg Base Tunnel.

**July 10 2000**

Blasting work commences at Bodio, marking the start of work in Ticino canton.

**March 30 1999**

The Federal Department of the Environment, Transport, Energy & Communications formally authorises the Gotthard Base Tunnel project. Tendering process for construction of the Amsteg, Sedrun, Faido and Bodio sections is approved; approval for Erstfeld section follows later.

**November 29 1998**

Swiss voters approve proposals for construction and financing of public transport infrastructure with 63.5% in favour.

**May 12 1998**

AlpTransit Gotthard AG is established as a wholly-owned SBB subsidiary.

**March 20 1998**

Swiss Parliament approves 'FinöV' public transport infrastructure programme worth SFr30bn that includes the NEAT projects; 55% of the costs will be met from taxes on heavy lorries, 19% from a 0.1% increase in VAT, 10% from fuel duties and the rest from loans.

**April 24 1996**

The Bundesrat decides to implement the NEAT project in stages. The Gotthard, Lötschberg and Ceneri Base Tunnels will be built, but the Lötschberg will be partly single track; two Zimmerberg tunnels will improve capacity near Zürich, but the Hirzel tunnel is postponed.

**June 13 2001**

First two major construction contracts are let for 15 km and 14 km drives from Bodio to Faido and Faido to Sedrun.

**June 28 1999**

Ceremony marks the start of Gotthard Base Tunnel work on Amsteg section in canton of Uri, followed by official event on November 4 marking the start of an access adit.

**February 4 1999**

Work starts on the first of two 800 m deep access shafts at Sedrun.

**September 27 1998**

Referendum approves distance-related heavy road vehicle tax for transit freight.

**May 8 1998**

Exploratory work in the Piora zone is completed, determining that the rock at the depth of the Base Tunnel alignment is suitable for tunnelling.

**February 1 1997**

Groundbreaking for Ceneri Base Tunnel exploratory bore at Sigrino.

**April 15 1996**

Construction work starts on intermediate heading at Sedrun.

**October 3 1995**

Project design for the Gotthard Base Tunnel commences.





# Milestones **GOTTHARD BASE TUNNEL**

**May 27 2003**

The first TBM on the northern side of the Gotthard Base Tunnel begins its drive from Amsteg towards Sedrun.

**July 19 2004**

Work starts at the northern portal of the Gotthard Base Tunnel at Erstfeld; work is now in progress on all five sections.

**June 22 2005**

Bundesrat releases credit for construction of the Ceneri Base Tunnel.

**September 6 2006**

First Gotthard Base Tunnel TBM breaks through into the multi-function station at Faido, nearly four years after starting its drive from Bodio.

**April 29 2008**

Contract worth SFr1.69bn signed for railway infrastructure equipment in Gotthard Base Tunnel.

**September 16 2008**

Swiss Parliament authorises credit worth SFr19.1bn for NEAT projects, of which SFr13.16bn are for the Gotthard and Ceneri Base Tunnels; funds for all the retained projects are now available.

**June 11 2009**

Main construction contract let for Ceneri Base Tunnel.

**October 15 2010**

Final breakthrough in the eastern running tunnel of the Gotthard Base Tunnel takes place between Sedrun and Faido.

**November 7 2002**

The first TBM commences its 15 km drive from Bodio towards Faido.

**September 10 2003**

Review determines that not all AlpTransit projects can be funded; the Zimmerberg Base Tunnel Stage II is suspended and the Hirzel tunnel dropped.

**April 28 2005**

Final breakthrough in Lötschberg Base Tunnel.

**June 2 2006**

Ceremony marks official start on Ceneri Base Tunnel.

**December 9 2007**

Lötschberg Base Tunnel opens, but it remains something of a bottleneck as only one of the two bores was fully fitted out.



Photo: BLS AG

**May 18 2009**

First railway infrastructure equipment is installed at Biasca.

**March 10 2010**

Official start of work on main drive of Ceneri Base Tunnel.

**March 23 2011**

Final breakthrough of the western running tunnel of the Gotthard Base Tunnel between Faido and Sedrun, marking completion of both running tunnels.

**December 2020**

'4 m corridor' is completed.

**December 11 2016**

Regular operations commence through the Gotthard Base Tunnel.

**June 1 2016**

Gotthard Base Tunnel opens as AlpTransit Gotthard AG hands over to SBB.

**January 26 2016**

Final breakthrough for the eastern bore of the Ceneri Base Tunnel.

**January 21 2016**

Final breakthrough in the western running tunnel of the Ceneri Base Tunnel.

**December 2020**

Ceneri Base Tunnel opens to regular traffic.

**August 2 2016**

Limited special 'Gottardino' service offers public trips to the Sedrun multi-function station until November 27.

**February 28 2016**

Referendum votes 57% in favour of a second Gotthard road tunnel.

**2015**

Wagonload traffic carried on Switzerland's trans-Alpine corridors increased by 7% in 2015 compared with the previous year.



**November 8-9 2015**

Maximum speed of 275 km/h reached with ICE-S test train in Gotthard Base Tunnel.

**October 1 2015**

Full-scale test operations start in the Gotthard Base Tunnel.

**June 2015**

Swiss Transport Minister Doris Leuthard starts the formal countdown to the Gotthard Base Tunnel's opening ceremony planned for June 1



Photo: AlpTransit Gotthard

**December 16 2013**

Transport Minister Doris Leuthard launches pilot operations in the western bore of the Gotthard Base tunnel between Bodio and Faido at up to 160 km/h.

## ADVERTISEMENT

# Mobile Maintenance Gates shut and seal the Gotthard Base Tunnel

Having been in the railway technology and plant construction business for many years, Nencki Ltd is well placed to cope with projects demanding knowledge and broad experience. The process begins with an analysis of a customer's requirements, and working out a customer-orientated solution, before managing the implementation right through to a successful installation and commissioning.

The company has an effective international sales organisation, an innovative technical unit and efficient quality-orientated production skills as well as expertise in project management and documentation, training and a flexible after-sales and spare part service. While mainly developing, producing and distributing mechanical systems with hydraulic drives, Nencki also develops its own electrical control systems and implements its own software.

Nencki is a family owned private company with about 120 employees, based at Langenthal, Switzerland, in a modern plant with well-equipped infrastructure. Thanks to nearly 70 years of experience and continuous growth, Nencki has gathered profound knowledge of the equipment needed for the efficient maintenance of railway infrastructure and a broad understanding of the essential requirements. Effective and modern tools enhance the quality and efficiency of installation, maintenance and cleaning work for catenary, track installation and tunnel construction. To meet specific customer requirements, exchangeable platforms can be equipped with various tools



and special equipment such as cranes, lifting and working platforms, catenary installation units and inspection and measuring devices.

## Mobile Maintenance Gate (MET) for sealing the Gotthard Base Tunnel

Built as part of the new trans-Alpine railway programme (NEAT) the world's longest tunnel will be opening soon. For maintenance, the operators of the Gotthard Base Tunnel need a number of special vehicles. Nencki has developed and produced two of these vehicles in co-operation with Elkuch Bator Ltd of Herzogenbuchsee.

During tunnel maintenance, sections must be isolated by sealing the tunnel diameter, and ventilated with fresh, cool air, so that the tunnel maintenance staff can carry out their work under bearable conditions. These blocking devices must not just seal the tunnel, but must also protect the workers against heavy drafts caused by possible differences in air pressure or shock waves from trains running through the parallel tunnel bore.

The Mobile Maintenance Gate (MET) is a rail-mounted special vehicle that can be positioned and anchored at a number of specially prepared positions in the Gotthard Base Tunnel. The main superstructure carries a foldable gate which can be raised and unfolded, and locked into position. Two vehicles are used at the same time, to isolate each end of the worksite. Once the work has been accomplished, the Mobile Maintenance Gates can be folded back into transport position and taken back to their stabling location outside the tunnel.

Once the vehicle has been driven into position inside the tunnel, two strong support beams move outwards to interlock with the anchorage in the tunnel wall structure, preventing the vehicle from being moved by air pressure differences which may act on the unfolded gate wings like

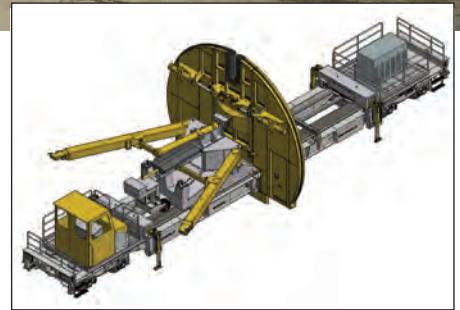

wind on a sail. Four hydraulic support feet also help to keep the vehicle in position.

To compensate for constructional tolerances and differences in the tunnel diameter, four locations have been equipped with a customised counter ring, fixed permanently to the tunnel lining structure. The unfolded gate flaps on the Mobile Maintenance Gate (MET) fit exactly into these counter rings, providing the essential seal for 95% of the tunnel diameter. A smaller flap underneath the vehicle folds down to seal the remaining cross-section.

## Successful tests and usage

The opening and closing of the Mobile Maintenance Gate (MET) is undertaken hydraulically, with electronic control of the end and intermediate positions. A built-in powerpack allows the vehicle to run safely over an extended period of time, even without an external power supply. When folded down into the transport position all parts of the wagon frame and superstructure fit within the clearance gauge, meaning the vehicle can be transported throughout the Swiss railway network.

Initial testing in the tunnel has been successfully carried out. As soon as the Gotthard Base Tunnel opens for traffic, both Mobile Maintenance Gates (MET) will come in to use on a regular basis.



Nencki Ltd  
Railway and Plant Technology  
Aarwangenstrasse 90, CH-4901 Langenthal, Switzerland

+41 62 919 93 93  
info@nencki.ch  
www.nencki.ch



# Policy commitment stands despite second road tunnel

**F**ew people had anticipated such a clear-cut outcome to the February 28 referendum. The choice was whether or not to build a second Gotthard motorway tunnel parallel to the existing bore, and the decision was firmly in favour, with 57% of the vote. Does this mean that Switzerland's support and affection for its rail network — reflected in government policy for several decades — is coming to an end?

A second road tunnel is deemed necessary because the existing 36-year old tunnel needs major repairs and improvements that require it to be closed to traffic. This work must be carried out between 2020 and 2025.

The proposal is for the existing bore to remain open while a second is built about 70 m to the east; cross-passages would link the two at intervals of 250 m. Once the second bore is complete, probably around 2027, traffic would switch to the new tunnel, allowing renovation work to proceed unhindered in the old one. Once this is finished, two bores would be permanently available from around 2030. The cost of the new tunnel and repairs to the old one is put at SFr2.8bn.

The alternative presented to voters was a temporary rail shuttle service for road vehicles. In practice, there would need to be one for cars through the old Gotthard rail tunnel and another for lorries through the Gotthard Base Tunnel; lorry loading terminals would be needed at Rynächt and Biasca, with three shuttles an hour in each direction. This idea, costed at SFr1.2bn to SFr2bn, failed to gain traction and did not have the support of the federal government. Militating against it was its temporary nature — the loading and unloading terminals would have to be dismantled after the existing road tunnel had been repaired.

## Controversy

Given the affection of the Swiss for their Alpine wonderland, it will come as no surprise that the idea of carving a second road tunnel through the heart of the mountains has been controversial. Looking back at Switzerland's recent transport policy, it is clear that the population has consistently supported protection of its treasured environment and was prepared to back proposals that would reduce or at least limit pollution from road traffic.

A referendum in 1992 supported



Photo: Federal Roads Office Fedro

Even though the Swiss electorate voted in a referendum in favour of a second Gotthard motorway tunnel, the government insists it is sticking to its policy of diverting transit freight from road to rail. **Murray Hughes** reports.

plans for the NEAT or AlpTransit project with its two railway base tunnels, and this was followed in 1994 by legislation protecting the Alpine landscape. Four years later voters supported the introduction of fees for transit lorries, some of the money raised being allocated to fund the railway base tunnels.

Opponents of the second Gotthard road tunnel argued that it would inevitably lead to an increase in road capacity. This, they said, ran counter to the much-vaunted policy of switching transit freight from road to rail.

The government countered by insisting that road capacity would not be increased. At the moment the existing Gotthard road tunnel has two lanes of traffic, one in each direction. The same will apply, the government says, when the second bore is open. Only a single lane of traffic will be permitted in each bore, the other lane being reserved for emergencies.

Apart from anything else, this arrangement will bring a major improvement in safety, not least because traffic will travel in only one direction in each bore, eliminating the possibility of head-on collisions. Not only that, but the system practised since 2001 whereby lorries are only permitted to follow each other at intervals of 150 m will also apply in the future. The average number of lorries using the Gotthard tunnel is currently 2,257 a day, according to the

**The Gotthard motorway tunnel handles an average of 2,257 lorries a day. The Swiss government insists that construction of a second bore will not increase capacity because only a single lane of traffic will be permitted in each bore.**

Federal Office for Transport.

The existing Gotthard road tunnel's safety record is far from perfect. In 2001-14 there were 181 accidents in which 21 people died and 107 were injured; the worst accident was a collision between two lorries in 2001 that led to a serious fire with 11 fatalities. Despite subsequent investment in safety improvements, emergency services were called out 95 times in 2014, on 22 occasions because of fires.

According to Dr Füglistaler, Director of the Federal Office for Transport, the traffic restrictions through the two road tunnels will be enshrined in legislation that will be difficult to overturn (p56). Sceptics point out that another government will be in charge by the time the second tunnel is complete, and that its attitude may be quite different, possibly leading to the legislation being changed. Transport, Environment & Energy Minister Doris Leuthard has given the road project strong backing, giving credence to suggestions that the Swiss government's long-standing favourable attitude to rail may be waning.

There is no firm commitment, for example, to complete the 34.6 km Lötschberg Base Tunnel. It was originally to have been built as a twin-bore structure, but to save capital costs the Bundesrat decided in 1996 that only the eastern bore should be fully equipped. The western bore has been

# GOTTHARD BASE TUNNEL Policy Review



excavated only between Raron and Mitholz and railway equipment is installed only over the 22 km between Raron and Ferden. A spur to Steg at the southern end to give access to the Valais has been excavated but not fitted out. In the past the government has indicated that the earliest feasible date for completing the second bore is 2030. In the meantime the single-track section remains a serious bottleneck for operator BLS.

Opponents of the second Gotthard road tunnel further highlight the pressure that the EU may bring to bear on Switzerland as road traffic rises in the future. Again, the Swiss government has a counter-argument. Leuthard points to a letter from European Transport Commissioner Violeta Bulc dated December 16 2015 in which the Commissioner states that 'the EU respects the decision of the Federal Council and of the Swiss Parliament to dig a second tube through the Gotthard which would be used as the main tube while the existing one is renovated'. Noting that 'one lane would be used for traffic in each of the two tubes while the remaining space in the tubes would serve for emergency and maintenance purposes', the letter goes on to confirm that this is acceptable under Article 32 of the Agreement on the carriage of goods and passengers by rail and road

**Rolling motorway.** About 7% of transit freight through Switzerland travels on rolling motorway services.

**Fig 1. Volumes of transit freight passing through Switzerland between 1984 and 2015 show that rail has held its own, with intermodal traffic rising steadily.**

concluded between the EU and Switzerland in 1999. The Agreement covered a range of policy measures, including the progressive relaxation of lorry weight limits from 28 tonnes to 40 tonnes, the maximum permitted since 2001.

In the Swiss government's view its policy of limiting transit road freight, primarily for environmental reasons, remains intact. In support of its policy it can point to a range of measures designed to favour rail, not least the construction of the 34.6 km Lötschberg Base Tunnel, opened in December 2007, and its much longer sister which is the subject of this special feature. Allied to that is the programme to increase clearances on the main north-south transit route across Switzerland so that 4 m high semitrailers can be carried on rail wagons (p64). The cost of the two base tunnels under the AlpTransit scheme amounts to SFr18.7bn, while the gauge enhancement programme adds another SFr990m, including SFr120m for work in Italy.

## Target may be missed

Yet it seems that the base tunnels alone will not suffice to achieve the objective of cutting the number of transit lorries to the target level of 650,000 a year by 2018. Significantly, Füglistaler writes that further tariff-related measures will be introduced

to encourage shippers to use rail.

While a further transfer from road to rail is expected with completion of the Ceneri Base Tunnel and the gauge enhancement programme in 2020, figures for 2015 suggest that the trend is slowly moving in the right direction, despite low diesel fuel prices. A total of 1.01 million lorries passed through Switzerland on the principal transit routes (Gotthard, San Bernardino, Simplon and Grand St Bernard) in 2015, down 2.2% from 2014 and as much as 28% lower than in the reference year of 2000.

Note, however, that higher volumes pass over the Brenner route in Austria, which handled 1.93 million lorries in 2015, an increase of 4% over 2014. Opposition to lorry transits in Austria remains strong, and the *Land* government of Tirol has plans to introduce restrictions on certain types of vehicle later this year. What effect this will have on the transit routes through Switzerland is unknown.

Freight moving by rail on the two main routes through Switzerland reached a record high of 27 million tonnes in 2015, a 3.3% rise over 2014. While the figure is largely driven by the strength of the German and Italian economies, rail succeeded in increasing its share of the market for the seventh year in a row, reaching a figure of 69%. On the other hand, strikes by railway staff in Germany are likely to have reduced the total volume of rail freight.

Analysis of the rail figures by route reveals that the Lötschberg-Simplon corridor carried 11.7% more traffic than in 2014, while tonnage on the Gotthard axis dropped by 2.3%. This can be attributed to closure for engineering work of the Luino route — which serves northern Italy's largest intermodal terminal at Busto-Arsizio — for the whole of

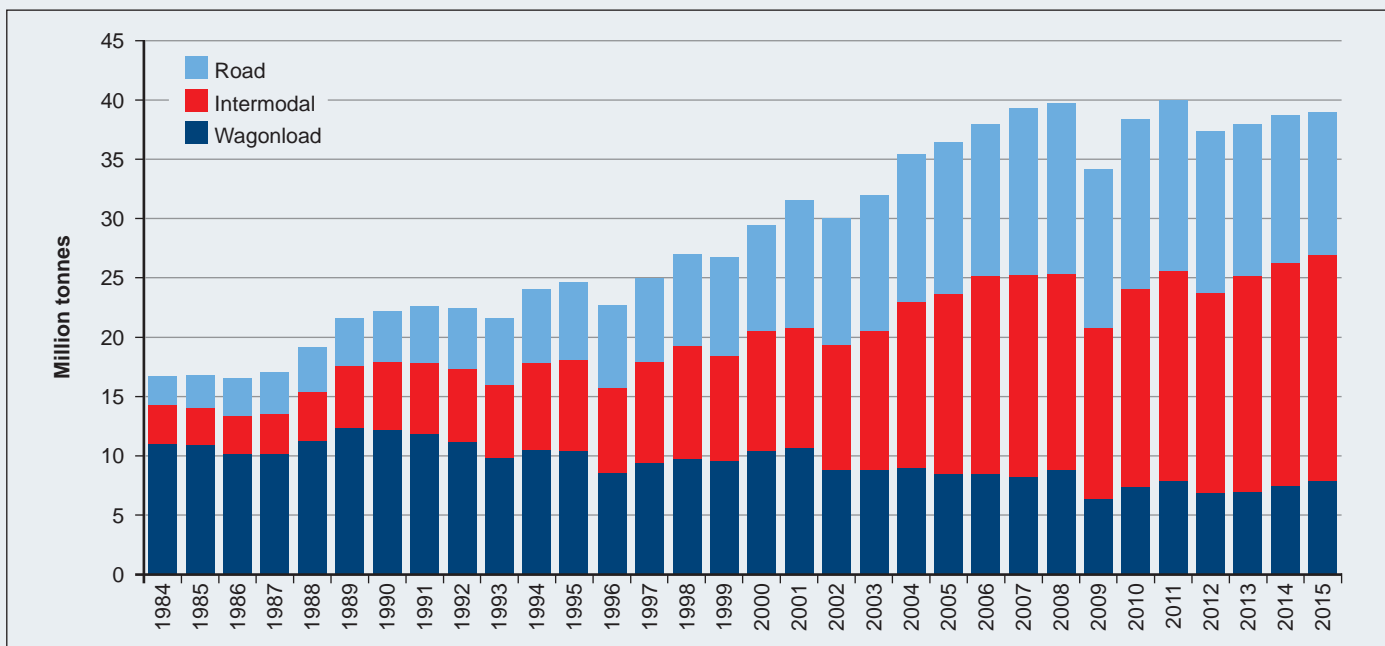



# Policy Review GOTTHARD BASE TUNNEL

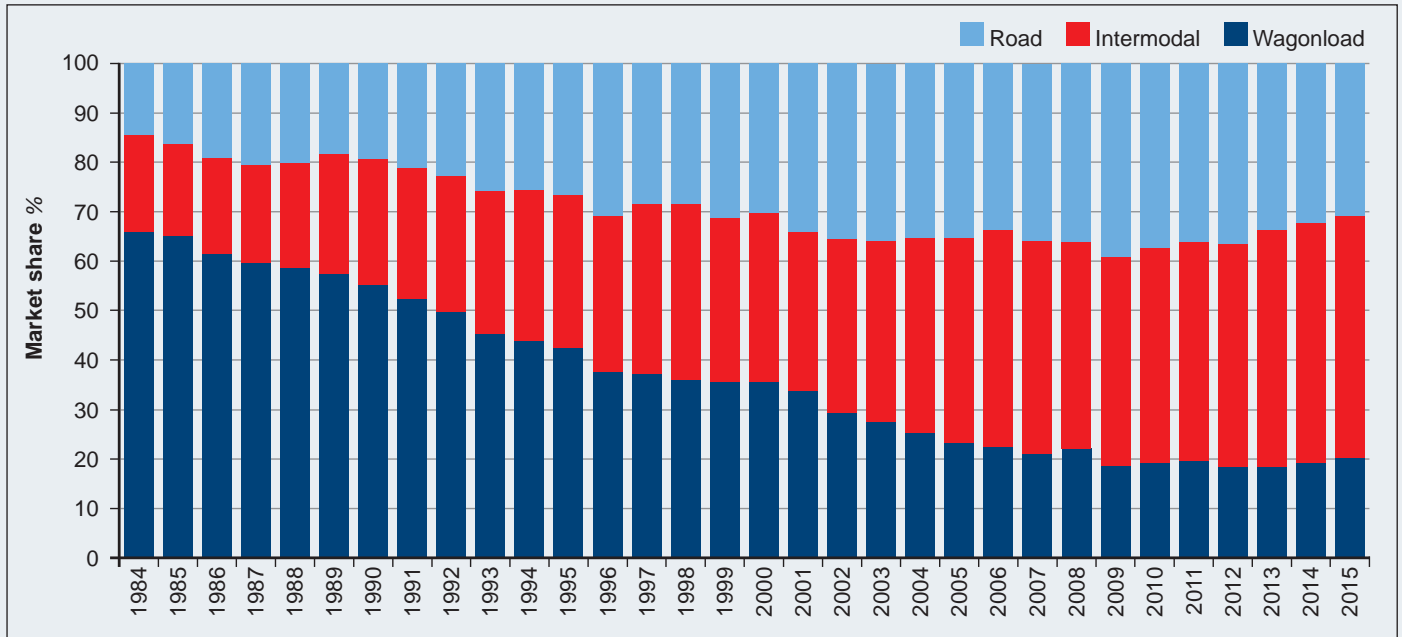

**Fig 2. The modal split of Swiss transit freight over the last 32 years shows that rail has regained market share since 2009.**

August 2015. Another factor was the need to equip freight locomotives with ETCS Level 2, which is now the only form of signalling on parts of the Gotthard main line. Compatibility problems with different versions of Level 2 forced SBB Cargo and SBB Cargo International to make significant changes to traction diagrams, while other ETCS

related issues affected traffic on the northern approach route to the existing Gotthard tunnel.

Of particular interest was a rise in wagonload traffic of 7.1% over 2014, whereas unaccompanied intermodal business increased by just 2.1%. The volume of rolling motorway traffic was unchanged, with 100 000 consignments

routed over the Simplon corridor.

Competition between operators on the two transit routes may influence volumes. SBB Cargo and SBB Cargo International together account for around 59% of net tonnes, with BLS Cargo handling 23.4%. The rest is split between Crossrail (13.3%), Transalpin (1.8%), DB Schenker CH (2.2%) and Railcare (0.5%). ■

## Stay ahead. Stay informed. Subscribe today.

The number one publication for the international rail industry



Subscribe today and **save 20%\***

[www.railwaygazette.com/subs112](http://www.railwaygazette.com/subs112)

\*For Terms and Conditions, go to [www.railwaygazette.com/terms](http://www.railwaygazette.com/terms)

Subscribers to Railway Gazette International receive these exceptional benefits

- **Issues delivered direct** to your home or office
- **Continuous Service<sup>†</sup>** – you can cancel your subscription whenever you like (minimum six issues)
- **Discount** – subscribe today and save 20% off the normal rate\*
- **Digital Issue** – free of charge, with access to our digital archive
- **Our Guarantee** – if you're not happy with your subscription, we'll refund the remaining issues to you

# Railway Gazette

INTERNATIONAL



**Railway  
Gazette**

INTERNATIONAL

# Archive articles



# World's longest rail tunnel will take traffic from road

**Work on access routes and shafts for the 57 km the Gotthard base tunnel is well in hand, and tenders have been called for four of the five main lots. In return for a SFr10bn investment in the AlpTransit Gotthard scheme, Switzerland will gain major environmental benefits by switching road traffic to rail**

SWITZERLAND'S population has voted on several occasions to protect the sensitive Alpine environment, making a clear choice in favour of a transport policy switching freight traffic from road to rail. A programme to build new transalpine rail routes was approved by referendum in 1992, creating the planning basis for the AlpTransit project to build base tunnels on the Lötschberg and Gotthard corridors. In 1998 another vote led to the introduction of a toll on lorries transiting Switzerland, and a clear-cut mandate to modernise and expand the national rail network. This paved the way for construction of the AlpTransit routes to go ahead. Together they form Switzerland's largest investment project, in return for which the Swiss will gain major environmental benefits.

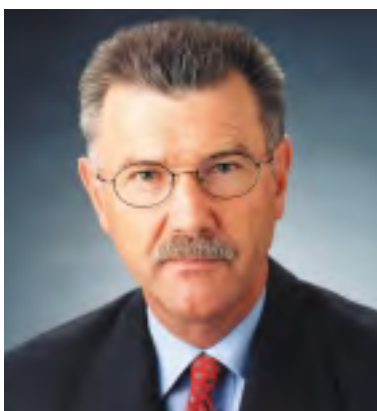

**Dipl-Ing Peter Zbinden**  
Chairman of the Board,  
AlpTransit Gotthard AG



AlpTransit Gotthard will create a north-south rail corridor designed for the long-term future. At the project's heart is the 57 km base tunnel, which will become the world's longest rail tunnel. To the north it will be complemented by the 20 km Zimmerberg tunnel, currently under construction, and to the south by the 15 km Ceneri base tunnel, on which work is also getting under way. Together, these projects will create a high-performance railway through the Alps whose summit will be no higher than 550 m above sea level – about the same as the cities of Bern or München (Fig 1). It will be significantly shorter than existing routes.

AlpTransit Gotthard will integrate Switzerland with the Europe's rapidly growing network of high speed lines. Passenger trains will be able to use the route at 200 km/h, cutting journey times between Zürich and

**Boring of the lengthy entrance adit at Faido was completed in mid-2001, and it has now been lined**

**Fig 1. Construction of the three base tunnels will create a low-level rail corridor between Basel and Milano**

Milano from 3 h 38 min to around 2 h 40 min, and providing excellent links to the domestic inter-city networks in Italy and Switzerland.

The project will help to satisfy the steadily growing demand for freight traffic on north-south routes. Transit freight moving by road is doubling every eight years, and if this trend continues, it will have a devastating effect on the Alpine environment. The objective of Swiss transport policy is therefore to switch this growing volume of freight to rail.

Together the Gotthard and Lötschberg base tunnel schemes will lift rail's capacity through the Swiss Alps from about 20 million tonnes a year to more than 50 million tonnes. Of SFr30bn being spent on rail modernisation and improvement projects over 20 years, around SFr14bn is earmarked for AlpTransit, with SFr10bn allocated for the Gotthard route. Of this, SFr7bn will pay for the base tunnel. These funds are being generated by a toll on heavy lorries passing through Switzerland, fuel taxes and a

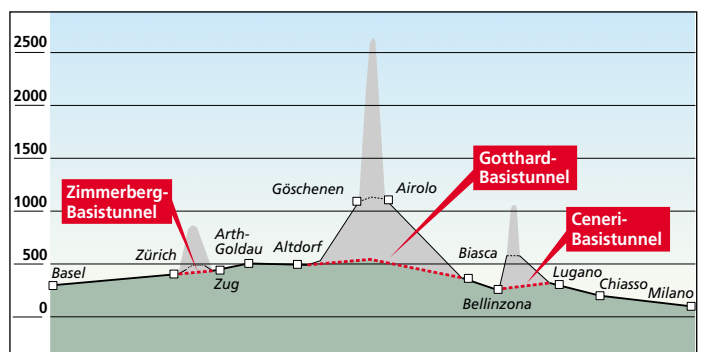

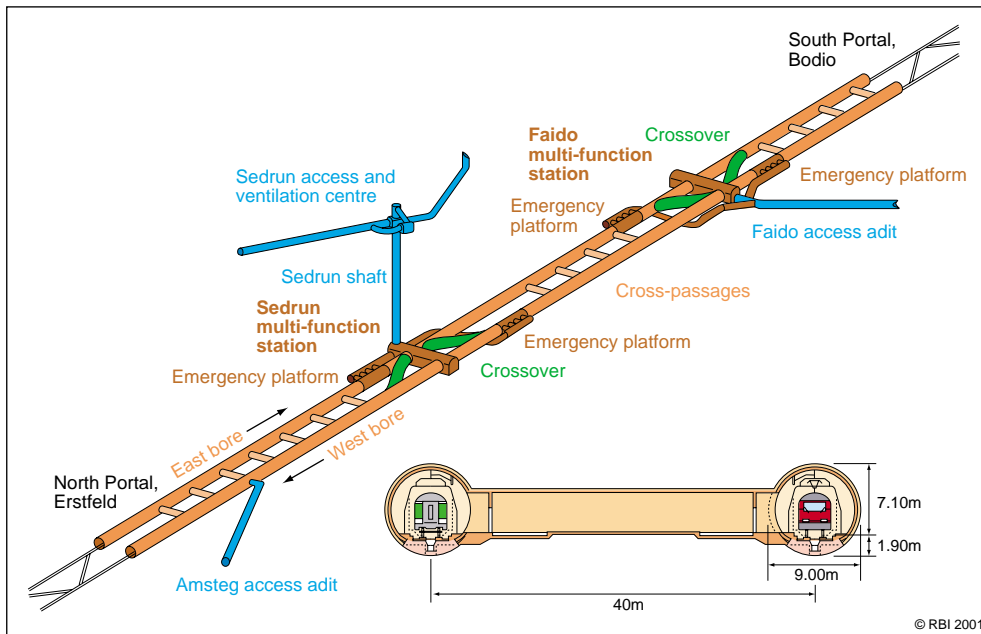

**Fig 2. The multi-function stations at Sedrun and Faiedo will include crossovers between the running tunnels and emergency platforms**

small percentage of value added tax. The base tunnel consists of two single-track bores, with cross-passages at 300 m intervals. At Sedrun and Faiedo, one-third of the way from each portal, so-called multi-function stations will be built. These will include crossovers between the two bores as well as emergency equipment and facilities.

### Progress to date

To reduce construction time and keep costs down, the work has been divided into five sections of different length. In Sedrun the adit and access shaft is already complete, and work on the main bore is due to commence in 2002.

Tunnelling began in the canton of Uri at a sod-turning ceremony on June 28 1999, launching work on the 11.4 km Amsteg section. The first blast for the 1.8 km access adit was fired on November 4 that year. Cross-section of the horseshoe-shaped adit is 60 m<sup>2</sup>. The adit lies in the Erstfelder gneiss forming part of the Aar massif, a good tunnelling material. An

**Right: Access to the Sedrun work-site is via a vertical shaft from a 1000 m approach tunnel**

**Construction base for the northern 11.4 km section is at Amsteg**



average of 45 workers were employed, achieving an average of 7 m a day with peak work rates of 14 to 16 m a day. The adit was completed in early summer 2001 within budget and on time.

At Sedrun there is a 1 000 m access tunnel, a 450 m ventilation tunnel and an 800 m vertical shaft, and work has been under way since April 15 1996. From the foot of the shaft, the two single-track bores of the Sedrun section will be cut 2 km north and 4.5 km southwards to reach the multi-function station at Sedrun.

Work on the vertical shaft began in autumn 1998, and excavation proceeded at 3 m a day. The final depth of 782 m was reached on February 22 2000, and in summer 2001 work began on excavating the caverns at

the floor of the shaft. The longitudinal cavern is 180 m long, with a cross-sectional area of 200 m<sup>2</sup>; the 100 m long transverse caverns have a cross-section of 180 m<sup>2</sup>. These caverns will serve as preparation sites and logistics centres for Contract 360, which covers the Sedrun section.

At Faiedo, where there is a 2.7 km access tunnel, work has progressed sufficiently for work on the main bores to start by the end of the year. Work began in Faiedo in July 1999, and driving of the access shaft started in December that year. The access tunnel falls on a 12.7% grade and has a cross-section of 62 m<sup>2</sup>. The rock formation here is the Leventina and Lucomagno gneiss, which is another favourable tunnelling medium. Installation of a concrete lining and an intermediate ceiling were undertaken in parallel with excavation.

Organisation and management of these three parallel worksites, together with ventilation from the construction bases, logistics and spoil disposal constitute the most demanding element of this part of the job. By mid-2001 the access tunnel drive was finished within the budgeted cost, and the concrete lining is now completed.

Since early 2001 some rather impressive machinery has been in use at Faiedo. This processes excavated material and turns it into concrete for construction work. Some of the material from the Faiedo section will be moved via a 5 km conveyor belt to an abandoned quarry at Cavienna, where much of the area damaged by quarrying will be restored and recultivated. The conveyor belt has been in use since early this year, and eventually it will have carried 2.2 million tonnes of material. Any material not used in Faiedo or sent to Cavienna will be moved to Bodio through the main tunnel and re-used there.

In Bodio work on the seven sublots has gone according to plan. For the Biasca section, which runs southwards on an open alignment, three lots are in hand, with contracts for the other four agreed. Most of the 50 ha construction site is already occupied.

More than half the 400 m open-cut section of the base tunnel is completed. Because of the track layout outside the tunnel, part of this section is a twin tunnel that gradually splits into two single covered cuts.

A 6 km conveyor belt carries the excavated material from Bodio into the Blenio valley where it is being used to fill a former gravel pit. The conveyor runs through a specially-built 3.2 km spoil tunnel with a 5 m diameter. This was cut with a TBM in nine months, and preparations are now in hand for



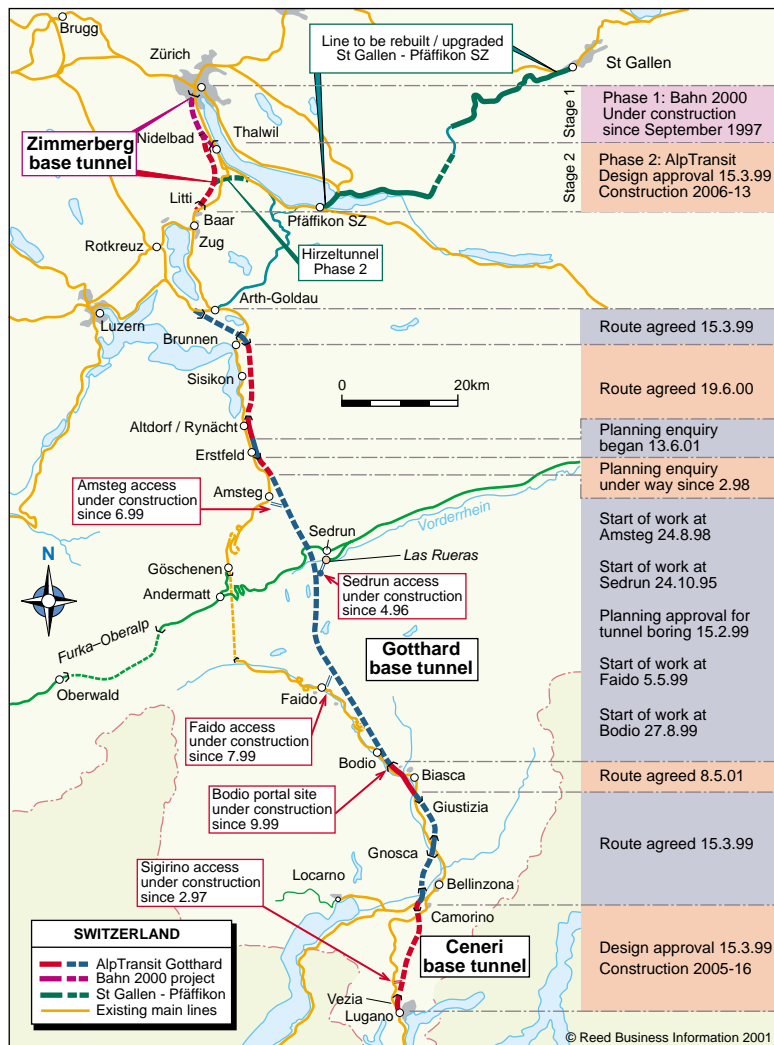

**Around 2.2 million tonnes of spoil from the Faido section will be moved via a 5 km conveyor belt to fill an abandoned quarry at Cavienna, allowing the area to be restored**

By July 2001 about 600 m of the planned 1 500 m East tunnel had been finished, and work on the West tunnel is poised to start shortly. So far all this work has been completed within the planned timescale and budgeted cost.

Boring of the main tunnels northwards from Bodio is expected to start in November 2002. The two TBMs will then pause en-route at Faido for their diameter to be increased, to cope with the higher rock overburden, before continuing towards Sedrun.

**Left: Fig 3. Each section of the base route has been subjected to an extensive alignment, design and planning approval process, which is still under way on some sections**

### Bidding process

Tenders for four of the five main lots were received in late 2000 and early spring 2001. This leaves the 7.5 km northern section at Erstfeld, for which the tendering process is scheduled in 2002-03. Each of the four major lots comprises a section varying from 7 to 16.5 km in length, each with two single track bores and cross-passages. Each lot is worth more than SFr3bn.

For the moment we can only report on experience with the main contracts for the Bodio and Faido sections. Six international consortia grouping 31 construction companies from seven

installation of the conveyor belt.

Near the Bodio portal the base tunnel runs through an unstable zone around 400 m long on the site of a landslide that occurred several hundred years ago. To avoid problems in this tricky area, it is being bypassed by a temporary access tunnel cut through sound rock. Work on this

1 200 m bore began in July 2000, and in January 2001 the axis of the base tunnel alignment was reached.

After completion of the 'branches' to the main alignment, excavation began on the single track tunnels running north and south. To the south, the tunnellers are working back towards the unstable landslide zone.

### Des projets gigantesques d'investissements pour passer de la route au rail

Les travaux sur les voies d'accès et les puits relatifs au tunnel de base du Saint Gotthard, sont bien en cours; quatre des cinq contrats pour ce tunnel principal de 57 km ont été soumis à un appel d'offres, à l'issue d'un processus méticuleux, mis au point pour minimiser les risques techniques et financiers. Les soumissions pour le cinquième contrat seront appelées en 2002-03 et la date butoir pour ce projet de grande envergure se situe en 2014. Le coût du projet du Gotthard, qui s'inscrit dans le cadre du programme AlpTransit, s'élève à 10 milliards de francs suisses, dont 7 milliards de francs suisses, rien que pour le tunnel, lequel comportera deux pertuis. En retour, la Suisse y gagnera en améliorations environnementales substantielles grâce au transfert des trafics fret et voyageurs de la route vers le rail

### Grossinvestitionen verlagern Verkehr von der Strasse auf die Schiene

Die Arbeiten an den Zufahrtsstrecken und Zwischenangriffsstollen für den Gotthard-Basistunnel laufen zügig voran, und vier der fünf Baulose für den 57 km langen Haupttunnel sind im Rahmen eines sorgfältig konstruierten Evaluationsverfahrens, welches technische und finanzielle Risiken auf ein Minimum beschränken soll, bereits in der Ausschreibungsphase. Die Submission für das fünfte Baulos wird 2002-2003 erfolgen, und das Datum für die Fertigstellung dieses Projekts ist 2014. Die Kosten für das Gotthard-Projekt, welches Bestandteil des AlpTransit-Programmes ist, belaufen sich auf 10 Milliarden Franken, wovon 7 Milliarden für den zwei-röhriigen Haupttunnel vorgesehen sind. Im Gegenzug erhält die Schweiz Umweltverbesserungen durch die Verlagerung des Reise- und Güterverkehrs von der Strasse auf die Schiene

### Un proyecto de inversión enorme trasladará el tráfico de la carretera al ferrocarril

La construcción de rutas y pozos de acceso para el túnel de base del San Gotardo ya está en marcha, y cuatro de los cinco contratos para el túnel principal de 57 km se han licitado en un cuidadoso y delicado proceso diseñado para reducir los riesgos técnicos y financieros. En 2002-03 se licitará el quinto contrato, y la fecha límite para la realización de este programa masivo será 2014. El coste del proyecto San Gotardo bajo el programa AlpTransit asciende a 10 mil millones de francos suizos, de los cuales 7 mil millones van destinados a la construcción de los principales túneles gemelos. A cambio, Suiza obtendrá substanciales beneficios medioambientales al trasladar el tráfico de mercancías y pasajeros de la carretera al ferrocarril



**A ceremony was held at Bodio earlier this year (above) to mark the holing-through of a 3.2 km tunnel. Completed in nine months, this will carry spoil away from the southern worksite. The 6 km conveyor belt linking Bodio with a disposal area in the Blenio valley is now being installed (below right)**

**Below: The southern approach to the base tunnel will parallel the existing Gotthard main line from Biasca using a mix of surface and cut-and-cover**

European countries submitted tenders for the two lots.

The tendering concept developed by AlpTransit Gotthard AG provides for a comprehensive risk analysis, assessing the methods and potential dangers of the work. This is followed by the specification of precisely-defined suitability and awarding criteria. Using these criteria, analysis and evaluation of the bids is carried out as the basis for letting the contracts. The criteria are set out in detail in the tender documentation in accordance with federal legislation for the award of public contracts.

On the basis of the risk analysis carried out for the Bodio and Faido lots, the following suitability criteria were established:

- proof of experience;
- proof of technical, managerial and staff competence;
- proof of financial standing;
- proof of a quality management system.

All bidders that submitted tenders within the deadline are checked for their fundamental suitability to carry out the work. Only then are their bids evaluated for the awarding criteria.

Risk analysis for the two lots led to the definition of the following award criteria:

- deadline guarantees;

- safety of work programme and working practices;
- worksite organisation;
- fitness for purpose and durability of the design;
- effects on the environment;
- quality management processes.

The tender documents set out the details of the evaluation process for the award criteria, and a threshold was set based on the award criteria to serve as a minimum level for contractors to qualify. Only after this are the economic elements of a bid and the tender price assessed.

Clearly the price in absolute terms cannot be the primary consideration, although it is of course one of the most important criteria for choosing the contractor. Inevitably, with such complex works over a long period and numerous risks, price cannot be the sole deciding factor.

For those holding responsibility at AlpTransit Gotthard AG, it is vital to establish if the bidders have made a sufficiently thorough assessment of the work, examined the potential dangers and taken measures necessary to manage the risks – and to check that they have integrated all this into the tender. This philosophy was made quite plain in the tender documentation and during worksite inspection visits for potential contractors. During evaluation of the tenders we found, inevitably, that the different bidders had not given equal weight to these considerations.

The process concludes with the award of the contract to the bidder providing the most cost-effective tender of those that have qualified by reaching the awarding criteria threshold.

The tendering process obviously demands a great deal from the bidders. But it was clear right from the start that the particularly demanding objectives in the contracts could not be met simply by basing a decision on price. Equally important are the

suitability of the contractor, the technical quality of the bid and how the contractor proposes to deal with the risks.

Every assessment carries the risk of making a wrong choice. To minimise this, the tenders were evaluated independently by two team of engineers, and the teams included specialists with plenty of experience of project management and tunnelling. The results of the independent reviews were carefully analysed and compared, and in most cases there was agreement. In a few instances we had to clarify different views by further technical analysis.

This detailed and comprehensive tendering analysis process is quite different from the functional specifications that have found favour recently in a number of other European countries. The award criteria and their weighting are intended as a measure of the technical evaluation of the bids. Questions to be answered include:

- How does the bidder plan to tackle the work and carry out the various tasks?
- What concepts and methods have been chosen to ensure that work is completed on time, that worksites are well organised, that working practices are safe, that the environment is respected and that quality is assured in a comprehensive way?

The final step will be analysis and comparison of the costs. Here the choice will be made by checking that the bid has been handled in a professional way, addressing the fundamental issues at stake. It is also important that there is real competition between the bidders, and there is no doubt that this was the case for the Bodio and Faido sections.

On the basis of the contract awarding process and experience to date, we believe that there should be no need for price negotiations in the traditional sense. ■



# Railway Directory

## Your Indispensable Reference Source for the Global Railway Industry

Completely updated, the *Railway Directory 2016* is the industry's most accurate and comprehensive source of global rail data. Also available in both print and online formats, it remains the first port of call for rail professionals, with over 22,500 key industry contacts, information on the latest urban / global rail projects\*\*, country and project profiles\*\*, over 190 colour maps and a comprehensive Buyers' Guide.

Published in two main sections – Railway Operators and Suppliers – *Railway Directory 2016* is clearly indexed, listed alphabetically and very easy to navigate. **Content includes:**

### Railway Operators

- Who's Who Key contacts and addresses worldwide
- Associations
- Regulatory Authorities
- Railway/Train Operators
- City Railways

### Suppliers

- Rolling Stock
- Rolling Stock Components
- Traction & Control
- Infrastructure A-Z
- Data & Information Systems
- Consultants/Support Services

Four ways to purchase	Please tick	£	€	US\$
Licensed version	Please call for more details			
Printed Directory Only	<input type="checkbox"/>	370	490	640
Web Only	<input type="checkbox"/>	400	530	705
Printed Directory and Web	<input type="checkbox"/>	525	640	990

### Your details

Title: \_\_\_ Initial: \_\_\_ Surname: \_\_\_\_\_  
Job Title: \_\_\_\_\_  
Company Name: \_\_\_\_\_  
Address: \_\_\_\_\_  
\_\_\_\_\_  
Post/Zip Code: \_\_\_\_\_  
Country: \_\_\_\_\_  
Tel: \_\_\_\_\_  
Email: \_\_\_\_\_

### Four payment options

- 1 Complete our online form at [www.railwaydirectory.net](http://www.railwaydirectory.net)
- 2 By Cheque: I enclose a cheque made payable to **DWV Media UK Ltd** for  £  €  US\$ Amount: \_\_\_\_\_
- 3 By Card: Please debit my  Visa  Amex  Mastercard  Switch for  £  €  US\$ Amount: \_\_\_\_\_  
Card No:                  
Issue No:    (Switch only)  
Valid from:    Expiry date:
- 4 Please invoice  me  my company.  
Order Number: \_\_\_\_\_  
Are you registered for VAT?  Yes  No  
VAT Registration No: \_\_\_\_\_

Please return to: **Railway Gazette International Subscriptions, DWV Media UK Ltd, 7th Floor, Chancery House, Sutton, Surrey, SM1 1JB, United Kingdom.**  
For our Privacy Policy, please go to [www.railwaydirectory.net](http://www.railwaydirectory.net) \*Includes data export of a maximum of 300 companies. \*\*Exclusive – Railway Directory Online now includes new and enhanced country and city profiles, plus the most comprehensive details of the latest urban rail project updates from around the world.



Your entire company can have full access to the *Railway Directory* and data with just one annual licence fee payment\*.

For more information, contact Sheena Rennie on +44 20 8652 5211 or email [sheena.ennie@railwaygazette.com](mailto:sheena.ennie@railwaygazette.com)

# 57 km breakthrough

**SWITZERLAND:** At 14.17 on October 15 a worker emerged from the cutting head of a TBM deep under the Alps to mark the breakthrough of the world's longest rail tunnel. Around 200 guests, including outgoing Swiss Transport Minister Moritz Leuenberger, were present to celebrate holding through of the 57 km Gotthard Base Tunnel.

Screens had been erected at the Sedrun worksite, Faido, Erstfeld and the Congress Centre in Luzern so that 3 500 people involved in the project could watch a live transmission of the breakthrough. Other viewers included Europe's transport ministers who were meeting in Luxembourg.

Leuenberger said the breakthrough was 'a symbol of what policy can do, when we make it together'. Although it was 'a day of joy for Switzerland and Europe' in the words of Dr Peter Füglistaler, Director of the Federal Transport Office, there was also sadness as eight tunnellers had died in accidents.

The base tunnel consists of two single-track bores 40 m apart linked by cross

passages at 325 m intervals. Including all access shafts and adits, there is 151.8 km of tunnel. Emergency stations and crossovers will be located one-third and two-thirds of the distance through the tunnel at Sedrun and Faido.

Whereas the summit of the existing 15 km Gotthard tunnel, which broke through on February 28 1880, lies 1 151 m above sea level, trains in the Base Tunnel will have to climb no higher than 550 m. The route will also be 30 km shorter, allowing passenger trains running at up to 250 km/h to clip a full hour off today's 3 h 40 min Zürich - Milano timing. Freight will benefit from a doubling of the maximum hauled load from 2 000 to 4 000 tonnes, lifting capacity to 40 million tonnes/year.

Opening is scheduled for the end of 2017, but Renzo Simoni, CEO of AlpTransit Gotthard AG, said it may be possible to hand the tunnel over to Swiss Federal Railways one year early. The next major milestone in the SFr9.83bn project will be the breakthrough of the western bore, due in April 2011. ❏



The breakthrough in the eastern bore was 30 km from the north portal and 2 500 m below Piz Vagira. Herrenknecht tunnel boring machine 'Sissi' had deviated just 10 mm from the vertical and 80 mm from the horizontal alignment.

# RENFE tightens belt

**SPAIN:** Presenting the national operator's 2011 budget to parliament on October 7, RENFE President Teófilo Serrano said income was expected to be €2.18bn, with passenger operations providing 87.7% of this. Freight would provide 12.3% or €269m, up from €233m in 2009 and the forecast of €241m for 2010.

RENFE expects to record 456.5 million passenger-journeys in 2011, up 0.5% on 2010 thanks to the opening of the high speed line between Madrid and Valencia on December 18 as well as the cross-border route between Perpignan and Figueres. The budget puts total expenditure at €2.64bn, including €385m in access charges, with an EBITDA of €324m forecast after government compensation for meeting public service obligations. In accordance with EU Regulation 1370/2007, RENFE is to present the government with details of its non-commercial services by November 30 to enable support to be budgeted for 2011-13.

RENFE's investment budget for 2011 is €635m, the smallest since infrastructure manager ADIF was spun out in 2005. The operator is to spend €390m on rolling stock next year, comprising €237m for new build and €153m for refurbishment. The Ministry of Development has a rail infrastructure investment budget of €7.1bn for 2011, of which 73% is to be spent on high speed projects, 18% on the conventional network and 9% on suburban networks. ❏



On October 14 ADIF President Antonio González and EIB Vice-President Magdalena Álvarez signed the second instalment of the €900m loan for construction of the high speed line from Madrid to Murcia and Alacant (RG 12.09 p10).

# HEMU-400X to roll in 2011

**SOUTH KOREA:** Hyundai Rotem plans to complete a prototype of the HEMU-400X high speed train during 2011. Launched as the Hanvit 400 project in 2007 (RG 5.08 p294), the HEMU-400X is a distributed power trainset with a design speed of 400 km/h.

With four axles powered by synchronous induction motors on each car, the prototype is due to undergo two years of 'stabilisation tests', according to Kim Ha Min, Research Engineer in Hyundai Rotem's R&D Centre. Only after extensive trials would a decision be taken on whether to progress to a production build.

Featuring 3 100 mm wide aluminium bodies, the HEMU-400X prototype will have a low static axleload of just 13 tonnes, comparable to some of the Shinkansen trainsets in Japan. The end cars will be 25.5 m long and the intermediate cars 2 m shorter; a 200 m long train would offer seats for 334 passengers.

The HEMU-400X is being designed for possible use on an ultra-high speed line that is proposed for construction parallel to the existing Seoul - Busan high speed route used by KTX services. Although the train's design speed is 400 km/h, it would normally be limited to 370 km/h in commercial service.

★ The Daegu - Busan high speed line is scheduled to open on November 1, cutting Seoul - Busan journey times by 22 min to around 2 h 20 min. ❏

# V300Zefiro order signed

**ITALY:** Trenitalia signed the €1.54bn contract for 50 V300Zefiro high speed trains on September 30. The joint bid from Bombardier Transportation and AnsaldoBreda had been selected on August 5 (RG 9.10 p7) but signing was delayed pending a possible challenge from losing bidder Alstom.

Designated ETR 1000, the trains are due to enter service from 2013. Production and commissioning will

be undertaken in Italy at Ansaldo-Breda facilities and technical leader Bombardier's Vado Ligure site.

The eight-car non-articulated trainsets will have capacity for 600 passengers. Distributed traction will enable service speeds up to 360 km/h, with 'unusually high acceleration' for fast journeys on winding routes. They will meet interoperability requirements for cross-border services. ❏

# Banishing the Alpine barrier

**IMMENSE** Forming the core of a high-capacity corridor through the heart of the Alps, the Gotthard Base Tunnel will accelerate inter-city passenger trains and allow heavy freight to speed through Switzerland. Murray Hughes introduces our special report.

Few railway projects are worthy of as many superlatives as the Gotthard Base Tunnel. Setting a fresh record as the world's longest rail tunnel, it will have taken 22 years from the date the first exploratory gallery was started to the day the first commercial train runs through in December 2016. To gauge the scale of the project, glance at the table of data (below) and you will quickly appreciate that this is an immensely ambitious scheme.

Instead of toiling up the long 2.6% gradients and round the loops and spirals of the famous Gotthard pass to a summit lying 1 150 m above sea level, freight trains transiting Switzerland between Germany and Italy will have a swift and easy passage, climbing no higher than 550 m above sea level on gradients no steeper than 1.25%. The trip will be shorter too, just 65 km via the new line between Altdorf and Biasca compared with 96 km over the old pass and through the existing Gotthard tunnel.

By using both the old and new routes, SBB will raise capacity on the Gotthard corridor from around 20 million tonnes a year to 42 million, with up to 220 freight trains a day compared with a maximum of about 140 today. Once the approach routes to north and south are upgraded to match the base tunnel, capacity will rise further to 56 million tonnes a year.

Interspersed with the freight flows will be up to 100 passenger trains a day, although questions have been raised about how these will be timetabled so as not to eat into the line's capacity. The problem is the considerable speed differential between freight and passenger services — the passenger trains will run at up to 250 km/h. Be that as it may, planners envisage that inter-city trains will take just 2 h 40 min to link Zürich and Milano, saving an hour compared with today's 3 h 40 min timings.

In the following pages senior engineers in charge of tunnelling, railway equipment installation and safety present the definitive story of this astounding project. Our report also looks at Ceneri Base Tunnel too, which forms a key element in the southern segment of the corridor. We invite you to read on. <<

## Gotthard Base Tunnel in numbers

Length <i>km</i>	57
Gauge <i>mm</i>	1435
Ballastless track <i>km</i>	115
Ballasted track <i>km</i>	39
Concrete used in track <i>m<sup>3</sup></i>	131 000
Total length of rails <i>km</i>	308
LVT rail support blocks	380 000
Points	43
Overhead line in tunnel <i>km</i>	114
Overhead line on open sections <i>km</i>	39
Mast foundations on open sections	560
Catenary support structures	2 860
Sprung support structures	3 200
Catenary feeds	220
Optic fibre cable <i>km</i>	2 631
Copper cable <i>km</i>	3 200
Leaky feeder radio cable <i>km</i>	120
Electrical cabinets for cross-passages	1 900
Air-conditioning units for cabinets	1 000
Lighting units	7 200
Transformers	250
Handrail <i>km</i>	118
Information signs	3 500
Radio Block Centre	1
Interlockings	4
Balises	900
Axle-counters	360
Marker boards	420



PHOTO: SBB

# The Gotthard Base Tunnel has a European dimension

**COMMITMENT** Building the Gotthard and Ceneri Base Tunnels is intended to switch transit freight from road to rail, but that depends on Switzerland's neighbours keeping their promise to upgrade their approach routes.

**Top:** The Gotthard Base Tunnel is expected to encourage even greater modal shift in freight traffic from road to rail.

The Gotthard has always been something special for Switzerland. Deep within the Alps, it lies right at the heart of the nation. An old legend relates how in the Middle Ages the Swiss confederates persuaded the Devil to build a bridge across the treacherous Schöllenen Gorge in a cunning deal that would open up the Gotthard pass to travellers.

During World War II, Switzerland's political and military leaders laid plans for the Swiss army to retreat into the so-called Alpen-Reduit, a fortified mountain stronghold in the Gotthard pass, in the event that Hitler's Germany should invade. Fortunately, it never came to that. Instead, the Gotthard myth

lives on in a different form — the 57 km Gotthard Base Tunnel sets a new world record as the longest railway tunnel. And that's something of which we Swiss can be proud.

Last October the miners holed through the first of the two running tunnels, and this triumph was followed in March this year by the breakthrough of the second bore. Huge celebrations marked these events, which made headlines right across Europe and beyond. Nor were they marred by any unpleasant surprises in terms of cost (p34).

Many people are under the impression that the Neue Eisenbahn-Alpen-Transversale, often known as the AlpTransit project, is now complete. That is definitely not the



**Dr Peter Füglistaler**  
Director  
Federal Office for Transport

case. After the miners' spectacular achievement, two further challenges remain.

One is to equip the tunnel so that it becomes a fully-operational railway, a task that includes tracklaying and installation of signalling, ventilation and other plant. The second task is to decide whether the tunnel will be ready to enter service in 2016, one year earlier than planned. This is looking increasingly likely. These are essentially technical and operational issues, which hopefully will be resolved without serious problems.

Another big question is how we can make the most effective use of the Gotthard and Ceneri base tunnels in tandem with the Lötschberg Base Tunnel. Here we face important economic and political challenges. To guarantee success, we have to rely on co-operation from our European friends.

**Switching road freight to rail**

The principal reason for building the NEAT base tunnels is to make it possible to shift transit freight traffic from road to rail. The Swiss voters have endorsed this strategy in several referenda. Across Switzerland there is a political and social consensus that the sensitive Alpine region should not be damaged by floods of lorries. The EU too has signed a treaty with Switzerland specifying that freight passing through the Alps should move by train rather than in lorries.

Yet so far the market is behaving somewhat differently. Experience with the Lötschberg, where the base tunnel has now been open for three and a half years, has shown that the new tunnel has triggered a strong rise in passenger traffic. There are good reasons to think that the same thing will happen with the Gotthard.

When it opens, the Gotthard Base Tunnel will lop a whole hour off the journey time between Zürich and Basel and Ticino. This will make a short break in southern Switzerland an attractive option for south Germans and for many German-speaking Swiss. This is excellent and a welcome development — and it is tempting to think that this will make the NEAT investment more worthwhile. The new tunnels give passengers much faster services and hence better performance. Most passengers are quite willing to

**‘We are counting on Germany and Italy to meet their treaty obligations by upgrading their approach routes’**

accept a certain increase in ticket prices that reflects improvements in service via the Gotthard; demand would hardly be affected.

These ideas should not cause us to lose sight of the original objective — we have made the transfer of road freight to rail a commitment

in the Swiss constitution and we have signed treaties with the EU to achieve the same objective.

There is no doubt that the new, faster, low-level line will make rail freight more attractive. Yet it is not certain if this will suffice to make forwarders and freight companies

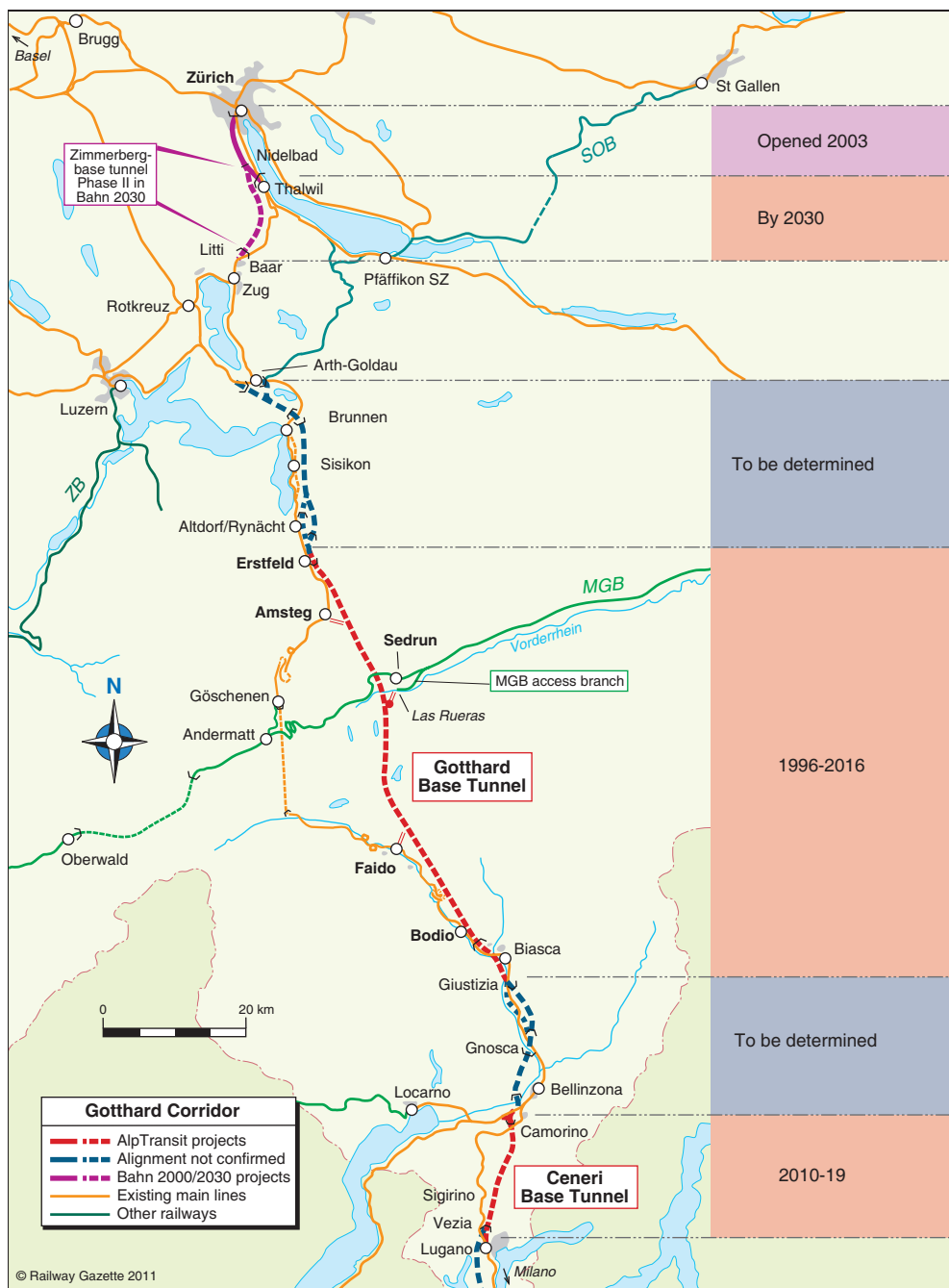

decide to make the switch from lorries to trains in sufficient quantities.

### Is more work needed?

For this reason we are currently looking at what else could be done. We are examining whether the Gotthard corridor should be upgraded to take 4 m high lorry trailers on rail wagons as these large vehicles are increasingly being used in international traffic. While the Gotthard and Ceneri base tunnels are designed to accept 4 m high lorries, the approach routes from Basel and the Ticino still require a considerable amount of work, with alterations needed to tunnels, platform canopies and signals. All this would require a special government credit of at least SFr600m.

In addition, we are subsidising every container passing through Switzerland on a train to the tune of SFr100. We would like to gradually ramp down these subsidies, and during the coming winter (2011-12) the government will put forward specific proposals and financial options to parliament.

Ultimately, of course, whatever we do nationally only deals with part of the problem. If freight is to be switched to rail for the long term, we have to rely on help from our EU neighbours.

Nothing is achieved by putting lorries on trains just on the Gotthard route. Firstly, it is uneconomic, and

## A template for other projects

**FINANCING:** To cover the cost of building the Gotthard and Lötschberg base tunnels the Swiss parliament authorised a credit worth SFr19.1bn at 1998 prices. For the last four years the expected out-turn cost has remained unchanged at SFr18.7bn, leaving a small surplus.

The Gotthard and the Ceneri base tunnels will together absorb a good SFr12bn of the total. This money will come out of a government fund for large railway projects known as FinöV, which is drawn from four sources.

The lion's share consists of two-thirds of the revenue generated by the Swiss lorry tolls. Second, up to one quarter of the cost of the NEAT base tunnels can be paid for from taxes on petrol and diesel fuel. Thirdly, 0.1% of value added tax is allocated to FinöV. And finally, FinöV includes federal loans of about SFr8bn, which will need to be paid back over the next few years.

FinöV is also paying for other Swiss railway projects such as links to the European high speed network and noise mitigation measures such as sound barriers and quieter brakes on freight wagons. As soon as these projects have been completed and the loans paid back, FinöV will, under current legislation, be wound up.

As the formula of a dedicated fund for railway projects has proved a success, at the start of this year the Swiss government suggested setting up a new fund which would ensure that money is available to cover the operation and upgrading of all railway infrastructure in Switzerland.

Under this proposal, the existing FinöV money would be transferred to the new Railway Infrastructure Fund (Bahninfrastrukturfonds, BIF). Parliament will vote on this suggestion next year before it is put to a popular referendum in 2013 or 2014. 

Emphasising the significance of this north-south European corridor, the southern portal of the Base Tunnel at Bodio is squeezed between the existing main line and the Gotthard motorway.

secondly, Basel, Luzern and Lugano would continue to be swamped by a tide of lorries. Our objective, therefore, is to transfer more freight to rail over distances of several hundred km, within the framework of the EU agreement on a transit corridor between Rotterdam and Genova.

The EU's White Paper published at the end of March (RG 5.11

p14), which calls for rail to handle freight moving over distances of 300 km and more, gives us hope. But what is needed are not concepts full of promises but swift and concrete action. We are counting on Germany and Italy to meet their treaty obligations by upgrading their approach routes to NEAT. It is also essential that Italy upgrades its section of the north-south corridor to accommodate 4 m high lorries.

We continue to trust that it will be possible to set up, at international level, a system for managing lorry traffic transiting the Alps. One possibility would be to establish an Alpine transit 'stock exchange' that would allow quotas for transalpine lorry trips to be established (RG 1.10 p66).

Finally, it would be a great help to us if countries such as Germany would raise the level of their lorry road tolls to a level close to the Swiss fees, so creating a real incentive that works in favour of rail. Switzerland is counting on its neighbours and on the EU to follow their words with action. If they do, then the Gotthard legend will live on — but this time as the embodiment of a transport policy in keeping with our times that favours the environment and enjoys sound international support. 



Photo: AlpTransit



**Subscribe today**  
[www.railwaygazette.com](http://www.railwaygazette.com)



**Stay ahead. Stay informed.**  
**Subscribe today.**

**First choice for the urban rail professional**

Metro Report International is the quarterly magazine dedicated to the urban transport professional, showcasing best practice in trams, light rail, metros, automated people movers and commuter rail. In print and digital formats, each edition includes in-depth news coverage, technical focus, key projects from around the globe, special features and market trends.

Subscribers to Metro Report International receive these exceptional benefits

- **Issues delivered direct** to your home or office
- **Continuous Service** <sup>†</sup> – you can cancel your subscription whenever you like (minimum six issues)
- **Digital Issue** – free of charge, with access to our digital archive
- **Our Guarantee** – if you're not happy with your subscription, we'll refund the remaining issues to you

**Metro Report**  
INTERNATIONAL

<sup>†</sup>For Terms and Conditions, go to [www.railwaygazette.com/terms](http://www.railwaygazette.com/terms)

# Eleven years to pierce the Alps

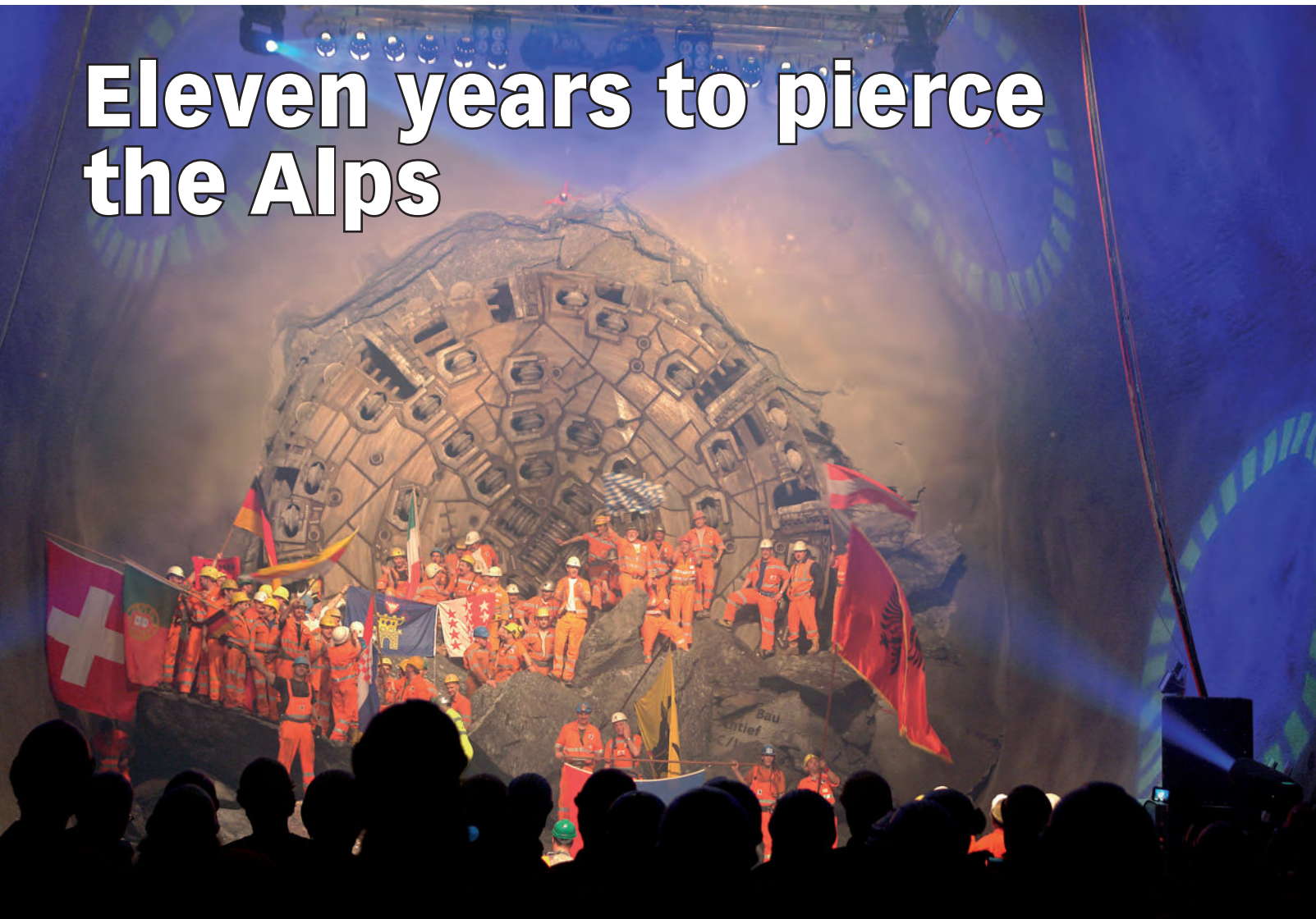

Tunnellers celebrate the breakthrough of the west running tunnel on March 23 2011.

**BREAKTHROUGHS** Deep under the Swiss Alps, contractors are still working flat out to finish the world's longest railway tunnel. With both main bores holed through, the project is on target for opening in 2016.



**Dr sc techn Dipl-Bauing**  
**ETH/SIA Renzo Simoni**  
Chairman, AlpTransit Gotthard AG

Few construction projects approach the Gotthard Base Tunnel in terms of scale or difficulty. Burrowing through Alpine rock towering up to 2 500 m above the rails, the twin single-track tunnels stretch for 57 km — longer than the Channel Tunnel (50.4 km) or the Seikan tunnel in Japan (53.9 km). The parallel running tunnels are linked at 325 m intervals by cross-passages, and there are access shafts or galleries at Amsteg, Sedrun and Faido. If these are added to the running tunnels, the total length of tunnel to be excavated

amounts to no less than 152 km.

Two 'multi-function stations' at Faido and Sedrun divide the tunnel into three sections of roughly equal length. Each station features a pair of crossovers which will allow trains to switch from one tunnel to the other. The stations fulfil the twin functions of providing a safe haven for passengers in an emergency (p46) and of housing ventilation plant and other items of railway equipment.

When the first exploratory gallery for the Gotthard Base Tunnel was dug in 1994, planners envisaged that tunnelling would take 10 years and that trains would be running by 2006. In the event, the tunnelling work took 11 years, but delays in the early stages

before the main works began mean that opening is not now envisaged until 2016. Nevertheless, the engineers and tunnellers have achieved a spectacular success in completing the two running tunnels, paving the way for the final stages of the project.

## Multiple workfaces

For construction purposes the project was divided into several lots: the northern approach in the open air from the Gotthard main line to the base tunnel; the Erstfeld, Amsteg, Sedrun, Faido and Bodio sections; and the open-air approach at the southern end which connects with the Gotthard main line heading south towards the

Italian frontier at Chiasso.

Construction adits for workers, materials and equipment were built at Amsteg, Faido and Bodio, and two 800 m deep access shafts were cut at Sedrun. This enabled tunnelling to take place simultaneously at several faces, so shortening the construction time and keeping costs in check. In all, no less than 28 million tonnes of rock were removed to create the two bores.

## Geological obstacles

Construction of the two running tunnels provided the opportunity to make a very detailed assessment of the geology in this part of the Alps. Despite a few unpleasant surprises, the geologists who predicted what the tunnellers would find proved to be largely correct in their assessment.

From the Erstfeld portal the alignment passes through the Erstfelder gneiss, a rock forming the northern half of the Aar massif. This material offered generally good conditions for construction.

In the Amsteg section the tunnelers encountered a mix of rocks that included 50% old crystalline rock, 41% plutonite and 9% volcanic rock from the Permo-carboniferous period, which was close to the geologists' predictions. However, beneath the Maderaner valley the tunnel teams unexpectedly struck a 600 m long section of medium-grained pale-coloured hard granite. This did not outcrop on the surface and was therefore a surprise.

The next obstacle was a 60 m section of gneiss that was disintegrating through exposure to heat and water. Found level with a line drawn from the Chrüzli Pass to the Etzli mountain hut, this material was at first sight solid, but it proved to be so leached out and damaged by hot water that fragments could be broken off by hand and rubbed into grains of sand. In the west running tunnel an inflow of water made matters worse, and this led to a collapse. The TBM was brought to a halt and it could only be restarted after major work to stabilise the surrounding rock.

Between the Aar massif and the Tavetsch intermediate massif there is a 400 m length of rock known as the Clavaniev zone. The rocks here are under heavy tectonic stress causing frequent faulting. This was a major problem for the construction teams who had to apply much technical ingenuity to ensure the passage of the TBMs.

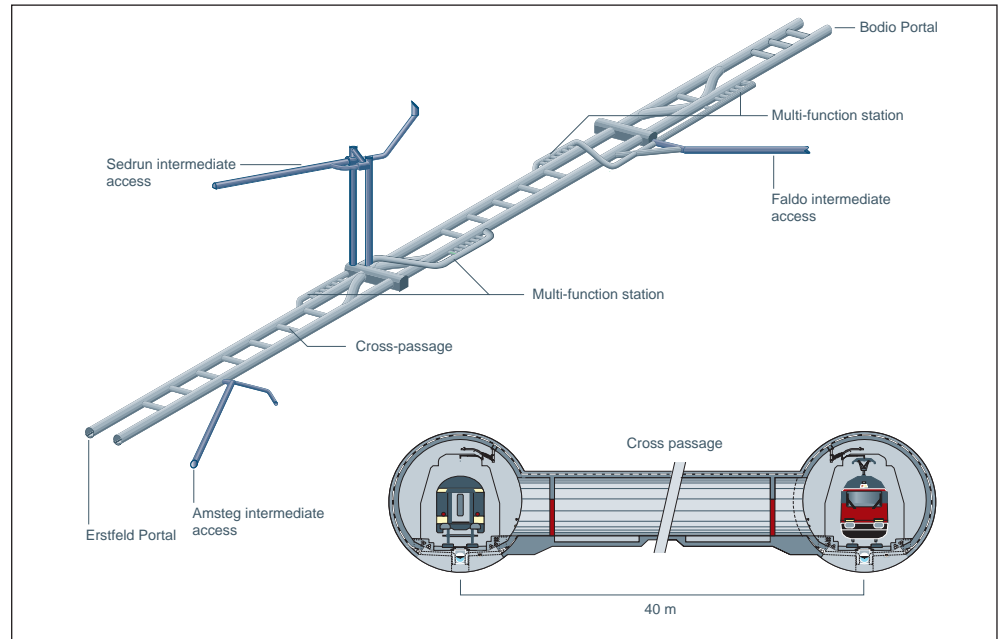

In the Sedrun section the alignment reaches the northern part of the Tavetsch intermediate massif, passing through it for 800 m. Created at a very late stage during the formation of the Alps, this area is marked by numerous faults. The southern side of this massif is 2.3 km long, the dominant rocks being gneisses and schist-gneisses. This section is less subject to stress and the firmer rock was better suited for tunnelling.

South of the Tavetsch massif the alignment passes through the Urseren-Garvera zone which features metamorphosed sedimentary rocks such as limestone, schists and dolomite. This was much more favourable for the construction teams, as predicted on the basis of knowledge gained during construction of the Gotthard motorway tunnel.

The Sedrun and Faido sections cut through the Gotthard massif itself, which consists mainly of different types of gneiss and schist. A few faults exist between the strata which in most cases did not cause too many problems. However, another unexpected fault known as '50b' proved to be 160 m long, causing serious difficulties.

The southern part of the Gotthard massif is formed of Medelser granite, the characteristics of which were hard to predict, and the tunnellers found that this rock stretched twice as far north as expected.

## The Piora zone

Long before work began, the project team was aware of the existence of the

Piora zone, where tunnelling conditions in what was termed a 'sugar dolomite' were expected to be execrable, so much so that the entire project appeared at one time to be in jeopardy. Fortunately, reason prevailed, and test bores were made to determine if there was a problem and how serious it would be. The tests in fact revealed that the tunnel alignment would pass through dry dolomite and anhydrite — a particularly attractive rock exhibiting white and blue-grey colours. The predicted problems did not materialise, and in the end it turned out that the rocks in the Piora zone were well suited for tunnelling.

South of the Piora zone the alignment reaches the Pennine gneiss zone where there is also a rock known as the Lucomagno gneiss. Although this is relatively good for tunnelling, the overburden of more than 1500 m led to technical problems. The 'MFS' fault, 30 m to 40 m deep, proved to be nearly 600 m in length. The fault zone also included the transition to the adjacent Leventina gneiss lying to the south, which with the 1300 m overburden led to numerous rock bursts, causing serious construction problems. The original plan had envisaged that the Faido multi-function station would be built at this location, but the construction difficulties led to it being resited further south.

By contrast, the Leventina gneiss is good tunnelling rock, and the only problem occurred when the miners encountered the '2705' fault shortly after work started on the Bodio section. This fault affected the alignment

**Fig 1. The Base Tunnel consists of two single-track running tunnels linked by cross-passages at 325 m intervals. 'Multi-function stations' with crossovers and emergency facilities are located at Faido and Sedrun.**



**Aerial view of the Erstfeld cut-and-cover tunnel and the railway equipment building.**

for more than 500 m, substantially delaying progress.

### Dealing with problems

Apart from many small fault zones less than 10 m in length, the alignment had to cross five major tectonic faults: the Öfi valley fault in the Erstfeld section; the heavily-faulted Tavetsch intermediate massif that included the Clavaniev zone; the '50b' fault in the Sedrun section; the 'MFS' fault in the Faido section; and the '2705' fault in the Bodio section.

The existence of the two most northerly faults had been known about before the start of work, and this had been factored into the construction programme. Despite the extra cost, additional tests were carried out to ensure that as much knowledge

as possible was gained before the tunnellers broke into these areas.

In any project involving long and deep tunnels, no matter how much trouble is taken to predict what will happen, the unexpected is bound to occur. The discovery of the previously-unknown '50b', 'MFS' and '2705' faults were examples of this, and in each case serious technical problems had to be overcome, incurring delays and additional costs. Nonetheless, looked at in the light of tunnelling history, the Gotthard Base Tunnel falls well within the statistically-expected boundaries.

### Construction methods

Conventional blasting was used for 44% of the base tunnel and tunnel boring machines for the other 56%. Four TBMs were required: two for the Bodio and Faido sections and two for the Amsteg and Erstfeld sections. Only for the Erstfeld and Sedrun sections was the choice of method dictated by local conditions — it was essential to avoid noise and vibration

on the northernmost section as the alignment passes directly beneath the village of Erstfeld which is only 100 m to 400 m above the tunnel.

Difficult ground conditions were predicted in the Sedrun section, where access via the two 800 m deep shafts was particularly difficult. For this reason conventional blasting was preferred. Elsewhere the choice was left to the contractors.

In many locations along the alignment, especially in the deepest sections, the temperature in the tunnel was very high, peaking at 50°C in some cases. This made it essential to provide excellent ventilation for the miners and other workers.

### Present status

On the northern approach between Altdorf and Rynächt various types of structure are required, including overbridges and underbridges, culverts and retaining walls. This work is still in progress.

This month is due to see the first railway equipment being installed

**The cutting edge. Despite fears that unstable rock in the Piora zone would present a serious obstacle, the TBM passed through without major problems.**

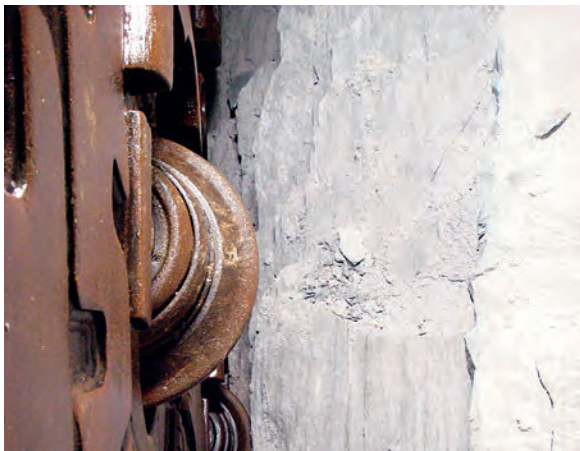

**‘The engineers and tunnellers have achieved a spectacular success in completing the two running tunnels’**

from the northern portal. A huge amount of preparatory work has been needed for this stage, including construction of a work base at Rynächt. As with the similar base at Biasca near the southern portal, the site occupies 70 000 m<sup>2</sup>. Workshops, offices, a control centre, canteen and visitor facilities will all be completed by the autumn.

Access tracks from Altdorf on SBB's Gotthard main line were laid nearly a year ago, allowing machinery and materials to be brought in by rail. Close to the northern portal, the shell of the railway equipment building is being fitted out.

Work on the cut-and-cover Erstfeld tunnel is on target, with the east bore already linked to the portal section, which was built using mining methods. Another 70 m have still to be completed on the west tunnel. Finishing works for the Erstfeld section were carried out at the same time and these too are now complete.

Lining of both running tunnels in the Amsteg section has also been finished ready for the installation of railway equipment. In mid-2010 the railway equipment consortium began installing components for the radio and cable networks. Another railway equipment building is being constructed adjacent to the traction power feed at Amsteg.

Last year blasting in the Sedrun section made good progress southwards through the geologically-favourable Streifen gneisses and in the Piz-Fuorcla zone, where the geology is more difficult. This required steel arches to be erected, together with additional rock bolts and advance anchors. This was one of the deepest parts of the alignment, with the height of the overburden increasing from 2 300 m to 2 500 m.

## Holing through

At 14.17 on October 15 2010 the first breakthrough took place when the TBM approaching from Faido cut through into the Sedrun section of the east running tunnel, 27 km from the southern portal. The difference in lateral alignment was just 80 mm and in the vertical direction a mere 10 mm.

After the breakthrough — which was staged in the presence of outgoing Swiss transport minister Moritz Leuenberger and numerous other guests — the TBM was dismantled in a specially excavated cavern before

being removed from the tunnel.

In the parallel west running tunnel the breakthrough occurred just after midday on March 23 2011. Also approaching from the south, the TBM had travelled 11 088 m from the multi-function station at Faido. Before that it had cut through 29 220 m of rock from the southern portal at Bodio. Dismantling of this TBM in a cavern at Sedrun began at the end of March, and this job will be done by August.

With the running tunnels complete, the main work left in the Faido section is to finish off the cross-passages, to concrete the inner shell and to seal the tunnel interior at the crossover junctions. Fitting-out of the multi-function station continues to make progress.

## First railway equipment fitted

In the Bodio section the west running tunnel will be the first to be fully fitted with railway equipment — this work has been in progress since May 2010. The contractors began with temporary items such as power supplies, lighting and communications for use during installation work, progressing to the optic fibre cables and medium-voltage cables for the permanent communications network and track. All of this was completed in March 2011.

May 2011 saw a start made on laying the connection to the Gotthard main line on the open section between Biasca and Osogna. Major works are required at the junction at Noda alla Giustizia, including a bridge over the Froda canal, a cut-and-cover tunnel at Giustizia and a holding basin for the Stabiello stream. In addition, a new road will be built over the cut-and-cover tunnel.

## The final stage

After more than a decade, the project is

entering its final phase. The civil engineering and tunnelling crews are starting to hand over completed sections of tunnel to the fitting-out and railway installation teams.

In 2014 the southern section of the tunnel will see the railway engineers starting to test their equipment. Lessons learnt from these early tests will be vital for the commissioning phase that will follow. Trial running through the completed base tunnel is scheduled to start in early 2016 to check that all the equipment is functioning correctly. Then, at the end of May 2016, AlpTransit Gotthard AG will hand the tunnel over to Swiss Federal Railways for acceptance tests and crew training ahead of the planned start of timetabled commercial services in December 2016. 

Its work over, the east tunnel TBM is dismantled in a cavern at Sedrun.



# Speed and capacity define tunnel fit-out

**FIT-OUT** Reflecting the complexity and demanding requirements of fitting-out the world's longest rail tunnel, more than eight years will elapse between the signing of the first railway equipment contract and the day when the first commercial train runs through.

**Dr Oliver Bratschi**  
Chief Engineering Officer, Railway Infrastructure  
AlpTransit Gotthard AG

Switzerland is making rapid progress with construction of a north-south high speed railway that will form a 90 km segment of the important Zürich – Milano corridor. Designed for trains running at 250 km/h, the Gotthard Base Tunnel and the Ceneri Base Tunnel are the two most significant projects on this busy rail artery.

The first railway equipment was installed in the Gotthard Base Tunnel in 2010, at the same time as work was still in progress at several of the tunnel faces. Now, as the civil engineering phase draws to a close, fitting out the two single-track bores



**Fig 1. Each 7.76 m diameter single-track running tunnel must be equipped with low-voltage and high-voltage cables as well as telecommunications, train control and the traction power supply.**

represents the final chapter in the long story of building the tunnel. The type of equipment chosen matches the goal of operating more frequent and faster trains — one of the objectives specified in the 1998 referendum on funding and upgrading the Swiss rail network.

Five complete systems are needed to turn the Gotthard Base Tunnel into a high-capacity railway: track; power supply for the tunnel's fixed equipment; traction power supply; telecommunications; signalling and train control.

### Ballastless track

Switzerland has considerable experience with the use of ballastless track in tunnels, most recently with the

Lötschberg Base Tunnel. Building on this knowledge, the Gotthard Base Tunnel will feature a ballastless design in which twin-block sleepers are encased in rubber boots round which a concrete mix is poured (p44).

A major advantage of this type of track is the ability to replace the various components. As there is no rigid link between the track grid and the supporting base, the sleepers can be replaced under just one rail should this prove necessary. The design allows the track support base to rest directly on the floor of the tunnel.

### Power supplies

Use of the tunnel by both passenger and freight trains places high

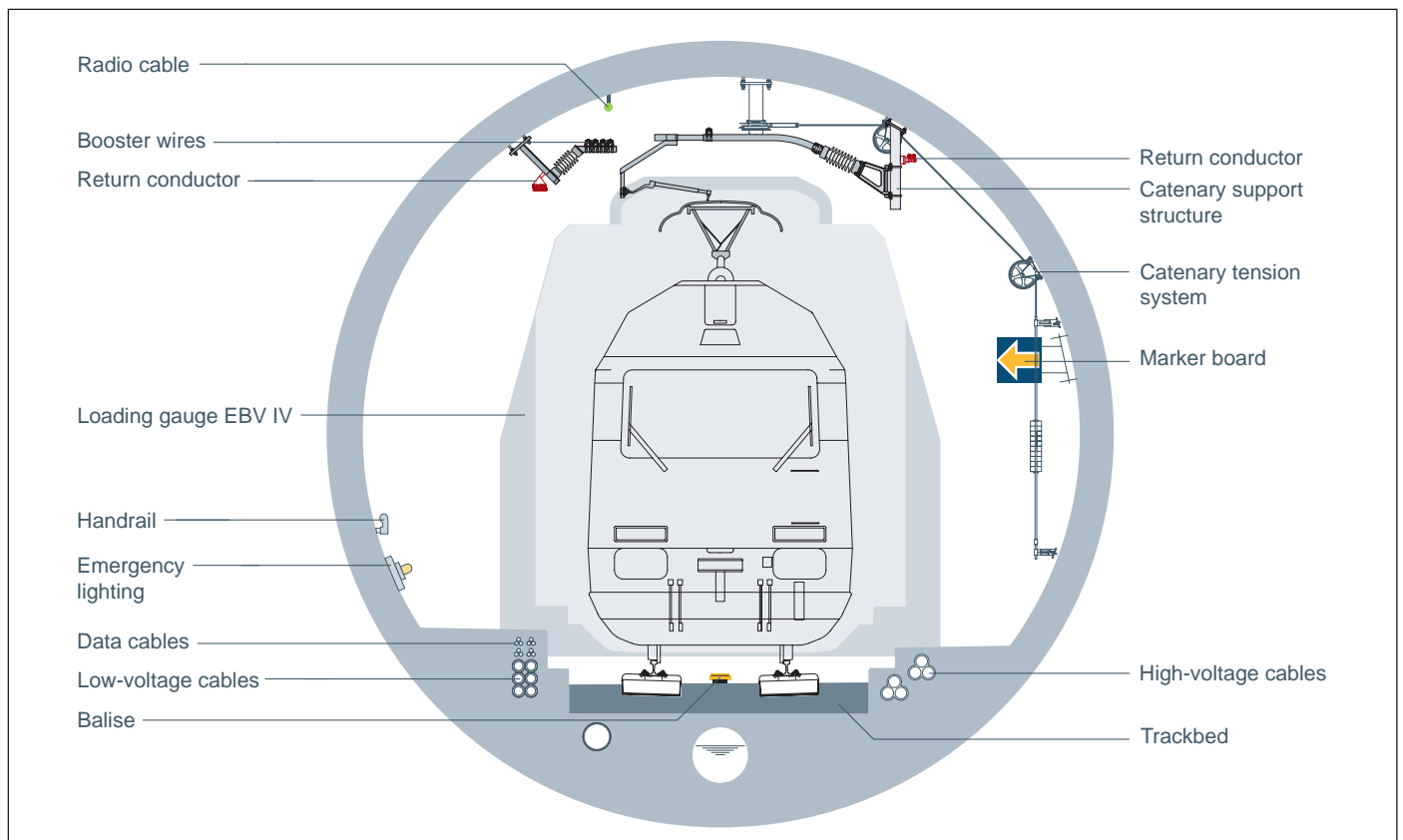

demands on the power supply and overhead line equipment, and the design engineers faced a serious challenge in choosing equipment that met the requirements. For example, the 250 km/h maximum speed of passenger trains made it essential to use a lightweight catenary, but this was in direct conflict with the requirement to power heavy freight trains which demanded use of a contact wire with a large cross-section.

This led to the choice of conventional overhead wire rather than a rigid bar catenary, but using a contact wire with a cross section of 120 mm<sup>2</sup>. Transit currents are mainly carried in the feeder cables, enabling the catenary to be built to a lightweight design that meets the mechanical requirements for trains running at high speed.

All railways in Switzerland with a 15 kV 16.7 Hz traction power supply draw electricity from a central high-voltage grid with 132 kV transmission lines. Traction power for the Gotthard Base Tunnel will be fed from substations at the Amsteg and Faido access shafts. Additional feeds will be provided at both portals; that at the north will connect to the existing main line network, but a new substation is being built at Pollegio to serve the southern portal.

For safety reasons, the reliability of the 50 Hz supply for the fixed equipment in the tunnel has to be very high. This will therefore be supplied by five largely independent high-voltage networks north and south of the Alps.

## A high-capacity corridor

**INVESTMENT:** The AlpTransit corridor has been designed for trains to run at 200 km/h to 250 km/h. Designed from the outset to offer maximum capacity, the alignment has a minimum curve radius of 5000 m with no gradient steeper than 1.25% on open sections. In tunnels, because of the increased air resistance, gradients will be limited to just 0.8%.

No level crossings are permitted on any part of the route.

Because of the high speeds and the density of the timetable, no maintenance work will be permitted on lines open to traffic. For this reason the distance between track centres in the open has been set at 5.5 m; this allows an area to be enclosed so that staff cannot walk on to the other track in error. When maintenance is needed in the tunnels, an entire section will be closed. ➤

Temperatures in the tunnel are expected to be as high as 40°C. Because of this and because access for maintenance will always be difficult, only the most essential equipment will be located within the tunnel. The 50 Hz network alone requires around 1 100 km of high-voltage cable and a further 1 050 km of low-voltage cable. In addition, there will be 1 100 km of optic fibre cables for data transmission. To avoid the possibility of mechanical damage, these cables are protected inside tubes in concrete structures level with the track at each side of the tunnel (Fig 1).

## Communications

Many items of railway equipment are automated, which means that the information transmission system also has to be ultra-reliable, in some cases handling both data and speech. The fixed communications network plays an essential role in linking the various components and systems. This includes the data network which transmits processing and operating data and a cable-based voice communications system.

Mobile communications are used for operating purposes, including GSM-R for the train radios and cab signalling. In addition, passengers will have telephone connectivity while passing through the tunnel to services provided by mobile phone network operators. All this demands a very powerful and reliable tunnel radio network incorporating both transmission and radiating media.

## Signalling and train control

The signalling and train control technology in the base tunnel includes a large amount of automated equipment forming part of a comprehensive network linking signals, axle-counters and points. Again, safety and reliability levels must comply with a very demanding

specification, as even minor faults could disrupt operations or lead to dangerous situations.

Trains passing through the tunnel will be controlled using ETCS Level 2, with train paths protected by interlockings and standard axle-counter technology. No lineside signals are provided, as all trains must be fitted for cab signalling and radio-based data transmission.

Equipment inside the tunnel includes: interlockings and axle-counters; points and point motor controls for the crossovers; monitoring technology linked to displays for dispatchers and train control staff; cab signalling with a Radio Block Centre located at Bodio and track-mounted balises.

Equipping the Gotthard Base Tunnel with ETCS Level 2 is an important Swiss contribution towards the goal of European interoperability.

**Construction of the railway equipment room is well advanced next to the traction power feed at Amsteg.**



## Operations

Ensuring that traffic runs safely and reliably through the Base Tunnel will depend on a suite of control technologies that monitor and oversee the signalling and train control equipment. This also checks for faults or problems as trains approach the tunnel and provides links between the signalling equipment and other tunnel apparatus.

The passage of trains between Arth-Goldau and the Italian border at Chiasso will be controlled from a

## Gotthard Base Tunnel contractors

### Overall project management

AlpTransit Gotthard AG, a 100% SBB subsidiary

### Civil engineering

#### Amsteg and Erstfeld sections:

ARGE AGN

Strabag AG, Tunnelbau Schweiz; Strabag AG

#### Sedrun section:

ARGE Transco-Sedrun

Implenia Bau AG (40%)

Frutiger AG (18%)

Bilfinger Berger Ingenieurbau GmbH (28%)

Pizzarotti SA (14%)

#### Bodio and Faido sections:

ARGE TAT

Implenia Bau AG

CSC Impresa Costruzioni SA

Hochtief AG

Impregilo SpA

### Railway equipment

Transtec Gotthard:

Balfour Beatty Rail; Alpiq InTec AG; Alcatel-Lucent Schweiz;

Thales Rail Signalling Solutions and Alpine Bau GmbH.

Rail	Voestalpine
Rail fastenings	Vossloh
LVT concrete blocks	Sonneville/Vigier Rail
Resilient pads for concrete blocks	Getzner

### Other suppliers

TBMS	Herrenknecht
Ventilation plant	TLT-Turbo/ABB
Cross-passage and crossover doors	Elkuch Bator AG
Door bonding	Collano
Overhead line fixings	Fischer-SFS unimarket AG
Power supply and other cables	Leoni

### Selected consultants

Anti-vibration measures	Rutishauser Ingenieurbüro
Track planning and consultancy	Basler & Hofmann
Design and consultancy	Nemetschek Engineering
	Gähler and Partner AG
Safety planning	HBI Haerter AG
Project management software	CIMdata
Environment, tendering, ventilation, various services	Pöyry
Various	Swiss Tunnelling Consultants

signalling and dispatching centre at Pollegio in Ticino canton. Here staff will oversee and control a range of equipment in both the Gotthard and Ceneri base tunnels.

The Pollegio centre will serve as a control centre for maintenance teams in both tunnels, and it will also be the base for emergency services dealing with any kind of incident.

### From contract to installation

In recent years SBB has acquired plenty of experience with different types of contract for major projects such as the sections of new line from Zürich to Thalwil and from Mattstetten to Rothrist. SBB also paid heed to the lessons learnt from the Channel Tunnel and the Köln – Rhein-Main high speed line in Germany.

Assessment of all these projects suggested that the lowest level of risk would be achieved by appointing a general contractor. This requires a detailed project specification to be drawn up as the basis for the tender. Once the contract has been awarded, the general contractor becomes responsible for the planning, installation and commissioning of all the railway technology.

A frequent source of disputes in major projects has been inadequate definition of the risks and their allocation between the different parties. The procedure adopted for the Gotthard Base Tunnel allowed the risks to be identified and allocated before the contract was signed. Despite this, AlpTransit Gotthard AG still carries several significant risks. These include:

- the possibility of exceeding the specified maximum temperature within the tunnel; simulation confirmed that temperatures inside the running tunnels will be very high compared with other Alpine tunnels;
- political, legal and interface-related changes to the contract and the claim management procedures that follow; changes to date have been targeted at meeting higher safety requirements, updating railway technology or providing improvements for the benefit of the population or the environment.

The contract signed on April 28 2008 with the Transtec Gotthard consortium covers planning, development, manufacture, delivery and installation of all the railway equipment for the base tunnel, including the open-air approach sections to north and south, as well as integration works, commissioning and maintenance up to the handover to the customer. Valued at SFr1.69bn, it was AlpTransit Gotthard AG's biggest single contract. Indeed, it was one of the largest ever contracts in the railway business worldwide.

### Start of work

Installing the railway equipment in the Gotthard Base Tunnel is a complicated and demanding task. To achieve the cost targets and meet the deadlines requires good coordination between the civil engineers and the installation teams, as well as between the separate railway equipment teams. A flexible installation programme is also essential — fitting out and commissioning the

tunnel will require no less than eight years from start to finish.

After a year of intensive planning, the first railway equipment was installed at the southern end of the tunnel in May 2009, when the contractor began to lay access tracks from Biasca station to the work base near the south portal. Between summer 2009 and spring 2010 this 60 000 m<sup>2</sup> site was turned into a busy and efficient base with accommodation for 230 workers, a canteen, an area for pre-assembly of components, storage compounds and buildings plus a control centre to oversee the work teams.

Starting from the southern portal at Bodio, the first temporary equipment and some permanent items were installed in the tunnel in May 2010, followed in September that year by the laying of the first ballastless track.

The complexity of the arrangements to lay the track and install other equipment presented the railway specialists with a major challenge. Costly preparatory measures were needed before work could begin.

In both running tunnels it is extremely difficult or impossible for rubber-tyred vehicles to pass, overtake or turn round, and the only means of access for large items of equipment is through the portals. Practically everything has to be brought in by rail from the main work bases at Erstfeld for the north portal and Biasca for the south portal. In some cases equipment has to travel over 40 km, demanding finely-tuned logistics.

The extreme climatic conditions inside the tunnel will also affect the installation process. Many items have to be protected from the high temperatures and humidity, and are therefore sealed in boxes or containers. Workers have the benefit of temporary ventilation and cooling plant.

### Work sequence

The entire installation process follows the same routine, with the sequence of work remaining unchanged throughout. First, the building supplies are taken in and cables are laid. This is followed by tracklaying, after which the completed track can be used by work trains to bring in the remaining equipment. Overhead line equipment is installed at the same time as the cross passages are fitted out. The main power cables are then laid, together with the links for data and other systems. Only then can the commissioning begin.

Efficient logistics and materials





handling are essential to ensure that the right components are in precisely the right place at the right time. Many items of equipment are mass-produced and have to be ordered in good time and then supplied and delivered, all the time meeting the required quality standards. Components are stored temporarily at the work bases and sorted according to the requirements for each shift or day before they are taken into the tunnel.

**Commissioning**

The commissioning process will be carried out in several stages. Once installation is complete, every single

component will be tested to ensure that it functions correctly. The first section to be completed will be the west bore between Faido and Bodio, which has been designated as the initial test section. More than 15 km long, it will be used from 2013 for tests at up to 200 km/h, allowing the complex interworking of all items of equipment to be thoroughly tested. Any lessons learnt from this test phase will be applied to the remaining sections of the tunnel.

Only when these tests have been completed can the actual commissioning start. This will be organised in two phases.

In Phase A AlpTransit Gotthard

**The Biasca work base near the southern portal was used to prepare equipment and machinery to lay the first ballastless track on the Faido – Bodio section.**

AG as the tunnel contractor has to prove that the installations function correctly and that the safety requirements have been met. Test running is scheduled to take place over a period of several months to ensure that every component works faultlessly.

In Phase B the main responsibility switches to the future operator, SBB AG. Only when SBB has demonstrated that all is working flawlessly — with staff in place and test freight and passenger trains operating — will the Federal Transport Office grant permission for the start of commercial services. SBB will also need to prove that it can cope with any kind of incident happening within the tunnel. 



# Precision laying of low-maintenance track

**ACCURACY** Laying 115 km of low-vibration, low-maintenance track in the confines of the Gotthard Base Tunnel to a tolerance of  $\pm 0.5$  mm represents an exceptionally demanding engineering challenge.

Laying the ballastless track required the use of specially-developed equipment and finely-tuned logistics. Here preparations are being made for the final concrete pour.

Among the multitude of tasks facing the railway equipment contractor, Transtec Gotthard, laying the ballastless track in the Gotthard Base Tunnel is particularly demanding in terms of logistics and complexity. The project required bespoke equipment, and Transtec Gotthard therefore invested in a carefully-designed set of specialised plant and mobile machinery, much of which was completely new:

- Wagons to transport the concrete rail support blocks;
- rail laying equipment;
- flash-butt welder;
- rail lifting jacks and equipment to support and position the concrete blocks;
- rail-mounted concrete mixing and placing plant, known as the Concrete Train;
- a special shuttle for transporting concrete in the tunnel;

- a moveable tent to protect the fresh concrete.

## Track design

The chosen trackform is LVT (Low Vibration Track) from Sonneville, now a sister company of the Swiss firm Tribeton, which in 2010 became Vigier Rail, part of the French Vicat group.

Right from the earliest days of planning for the Swiss base tunnels, SBB had been on the lookout for a suitable track design. Taking the well-established twin-block sleeper with tie-bar formula for ballasted track, SBB worked with Roger Sonneville to develop a version which could be placed in rubber boots with elastic pads inside for use with ballastless track. The resilience of the pads was intended to replicate the resilience of the ballast while the rubber boot separated the twin blocks from the concrete base in which they were embedded.

SBB undertook an initial trial in the Bözberg tunnel in 1966 and laid a test section in the Heitersberg tunnel in 1974. Subsequent projects, mainly involving tracks in stations, saw the connecting tie-bars removed after installation to allow better access to the track.

The design was later selected as a candidate for use in the Channel Tunnel. The very tight specification concerning gauge widening led Sonneville to adopt a deeper concrete embedment, which was only possible by eliminating the tie-bars. This was the birth of the LVT design with independent sleeper blocks.

An 800 m section of LVT was tested in the Grauholz tunnel between Bern and Mattstetten in the 1990s with a view to its installation in the base tunnels. It was subsequently used in the Zimmerberg tunnel and the 34.6 km Lötschberg Base Tunnel, where the design life was set at 50 years. A similar lifespan is anticipated for the Gotthard



on the raised walkways at the side of the tunnel; the shuttle then places the concrete around the blocks to complete the track.

Within the 20-day cycle only 10 days are needed for concreting, and at peak times about 85 people work on a three-shift system to complete an 'installation length' of 2 160 m; this figure was determined by the 120 m lengths of rail. Tracklaying will be completed in six stages, with each stage consisting of 16 km to 20 km.

**Left:** The 500 m long Concrete Train produces up to 235 m<sup>3</sup> of concrete in two shifts. The concrete pump vehicle is nearest the camera.

## Installation logistics

The first few km of track were laid northwards from the south portal in the west or northbound tunnel which is destined to be used for the first running tests. As tunnel finishing works were still in progress, tracklaying at the southern end was halted around the end of March. The tracklaying teams and equipment moved to the north portal where they will begin to lay track southwards in July. This involved the Concrete Train being turned on a loop at Bellinzona before the journey north over the existing Gotthard main line. 

version, although observation of existing trackforms suggests that the life of the concrete elements could be considerably longer.

## Laying operation

The track is laid in sections on a 20-day production cycle. With the tunnel invert concrete in place, 120 m lengths of UIC60 head-hardened rail from Voestalpine are pulled on to the invert by a rubber-tyred tractor. These rail sections are then joined to form an endless string using a flash-butt welder. At this stage the rails are temporarily fixed to the tunnel invert, and the tractor moves forward to repeat the cycle.

The next part of the process is to lay and position the concrete blocks which are supplied fully assembled with the resilient pads below the base inside the rubber boots taped to the blocks. The blocks are made on a specially-built production line at the Vigier Rail plant in Müntschemier near Bern. They incorporate pre-installed Vossloh rail fastenings with spring clips arranged in position ready for assembly. A train of 14 purpose-built wagons takes the blocks into the tunnel, and a rail-mounted crane picks up 60 blocks at a time and drops them through a slot into the centre of the track for positioning. Shuttering is added for the prefabricated drainage ducts and crack inducers are installed.

The rails are lifted into position with the blocks positioned at 600 mm intervals under each rail string. The fastening screws are then loosened and the clips pushed into their final position before the screws are tightened. With the use of gauge bars, the track is now roughly in its final position. Adjustable lifting jacks below the track

and adjustable lateral props combined with laser beams then allow the track to be aligned to within  $\pm 0.5$  mm.

The clips are greased to prevent the base concrete from adhering to them, and protective covers are placed over the rails. Rails are inclined at an angle of 1 in 40.

The final stage of the process is to pour the concrete. Up to 235 m<sup>3</sup> is produced by the Concrete Train, enough for two shifts totalling 15 h during which more than 200 m of poured slab track is completed.

Depending on the workload, the train may be formed of 20 or more vehicles pushed by a locomotive at the rear. A crew welfare car and workshop car are marshalled next to the locomotive, followed by 10 aggregate wagons, a water tanker, a power plant, two cement wagons, the mixing unit, a wagon for waste to which a concrete batch that tests badly can be diverted, and a pump wagon for placing the concrete.

The aggregate wagons are linked by conveyors which carry a carefully tailored mix of sands and graded stones forward to the concrete batching plant; the materials are accurately weighed by computer before mixing. The water and cement wagons also feed the batcher under computer control using pumps or pneumatic lines. Finally, a Putzmeister pump on the leading wagon delivers the concrete into a rubber-tyred shuttle that runs

**Above right:** The trackwork contractor built a special test track at Biasca to train staff, to determine the right concrete mix for the Concrete Train and to check the performance of the rubber-tyred concrete delivery shuttle.

**Right:** The Concrete Train mixes and pours enough concrete for a 200 m section of track over a period of 15 h.



Photos: Balfour Beatty Rail

# Safety takes centre stage

**PREVENTION** Right from the earliest planning phase, safety in the Gotthard base tunnel has been accorded a high priority.

**H P Vetsch**  
Head of Operations & Safety  
AlpTransit Gotthard AG



Apart from its unprecedented length of 57 km, there are many good reasons why the Gotthard Base Tunnel has been described as the project of the 21st century. One is the extent to which safety considerations were built into plans for construction and operation, into the design of technical equipment and into the arrangements for dealing with emergencies. Unprecedented attention was also given to safety planning in the process of integrating all the tunnel's different items of equipment and the procedures for using it.

AlpTransit Gotthard's safety specialists were sometimes faced with completely new requirements as the safety strategy was drawn up. In essence, the fundamental concept is to gear everything to prevent any event occurring that could lead to a disaster and, if something should occur, to ensure that the consequences are kept to a minimum.

Although the chances of a serious accident are statistically very small, the safety planning measures have to assume that an accident or a fire may occur at any point in the tunnel. Should that happen, then the damage to people, materials and infrastructure must be minimised.

Thus the safety concept rests on these three objectives:

- prevention: no events incurring a safety risk should occur in the tunnel;
- minimise the consequences: limit any damage that does occur;
- ensure that passengers have a fair chance of escape: they should be able to rescue themselves.

## Prevention measures

To ensure that the risk of any event occurring is as low as possible, the Gotthard Base Tunnel was designed



The recesses for the crossover tunnel doors are currently under construction.

with two single track bores, one for each direction. This rules out the possibility of a sideways collision between trains.

Similarly, the number of points and crossings in the tunnel has been kept to an absolute minimum. In terms of equipping the infrastructure, use of the latest train control technology with cab signalling should ensure that the risk of an accident occurring because of human error is reduced as far as possible.

Wayside checking and monitoring devices will be installed on the approaches to the tunnel to ensure that trains with damaged axles or wheels, clearance infringements or shifted loads do not enter the main bores. The equipment will be located some distance from the tunnel entrance so

**Emergency rescue trains will be stationed close to the north and south portals of the Gotthard Base Tunnel.**

that if an alarm is activated the train can be halted before it reaches the portal.

The use of emergency braking equipment and alarms has also been carefully considered. It is out of the question for a driver not to be in full control of the train at all times, in order to stop the train in a controlled manner. Allowing passengers to intervene and bring the train to a stand makes no more sense than allowing an airline passenger to force an aircraft to make an emergency landing. So activation of an alarm will notify the driver and controller, but not trigger an emergency brake application.

In addition to physical measures relating to the infrastructure and the approach routes, safety devices on the rolling stock need to be improved on a continuous basis, so that the risk of train equipment causing a safety problem is minimised. For example, it is important to be able to identify hot axleboxes or damaged wheels on passenger vehicles. Equally, the use of derailment detectors on freight trains carrying dangerous goods is just as important. On passenger trains

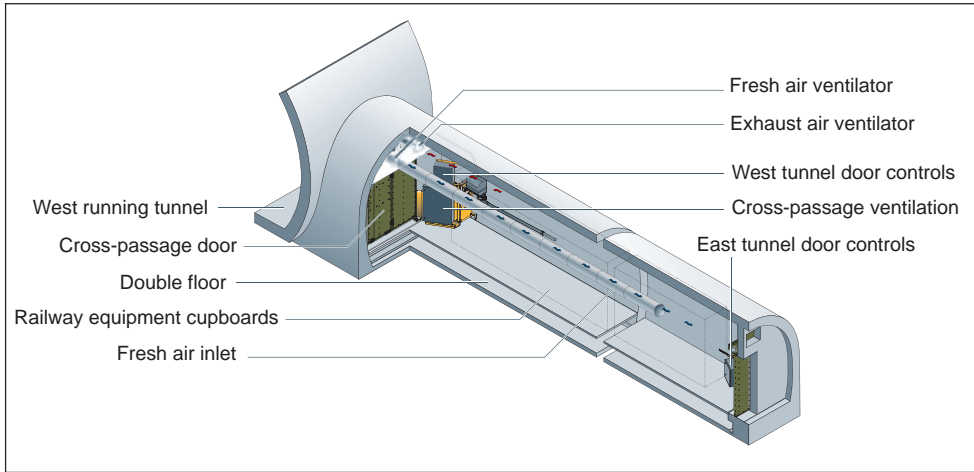

**Fig 1. Cross-passages between the running tunnels are designed to be used as emergency walkways for passengers.**

flame-retardant materials will be required, and locomotives or powered vehicles in fixed formation trainsets will be fitted with fire detection in the equipment compartments. All this should help to ensure that a fire does not break out in the world's longest railway tunnel.

**Limiting damage**

The two multi-function stations in the base tunnel will serve as safe havens and emergency access points where passengers can be evacuated quickly from trains in a controlled manner. Should a train passing through the base tunnel develop a technical fault, it will be brought to a halt by the train control system at the next emergency station.

If required, a failed train will be hauled out of the tunnel by a special rescue train. Already well proven in service in Switzerland's other long tunnels, these rescue trains will be stationed at each end of the base tunnel. These self-propelled trainsets carry railway and emergency staff who are trained to provide first aid, to free trapped people and to fight fires.

Should an accident or fire occur — despite all the prevention measures — then standardised procedures will be invoked to limit any damage. Clearly, such procedures will be constantly updated and practised to ensure that they are effective. Management of an emergency will be handled from the tunnel control centre at Pollegio. From here railway staff and the emergency services can be called in as required.

**Passengers able to rescue themselves**

When smoke and heat develop inside a tunnel, critical conditions are

reached much more quickly than in the open air. Not only that, but some time is bound to elapse before emergency teams reach the site of an incident. For this reason it is important that passengers and train crew can reach a place of safety by themselves within a few minutes.

The passengers and train crew should be able to leave the scene of an accident or escape from a train fire anywhere within the tunnel and not just at the emergency stations. The Gotthard Base Tunnel has therefore been designed with cross-passages between the two running tunnels located every 325 m.

The cross-passages can be used as an escape route from one running tunnel to another. Signage and emergency lighting is designed to assist anyone escaping from a fire or other disaster to walk through a cross-passage to reach the safety of the other running tunnel, where they will be rescued by another train.

**Ventilation management**

The main ventilation system is designed to prevent the atmosphere in the running tunnels from becoming fouled by smoke or other pollutants. It will also provide fresh air for maintenance staff working in the tunnel.

The crossovers between the two running tunnels, which allow trains to be switched from one bore to the other in case of engineering work or emergencies, will be fitted with doors across the tracks. These will remain closed during normal operation in order to keep the two running tunnels aerodynamically separate, and will only be opened only if trains need to switch bores.

The multi-function stations are

also protected by emergency doors across the running tracks which will normally remain closed and only be opened for a train in an emergency.

If a train on fire is brought to a stand in one of the multi-function stations, the emergency ventilation equipment will blow air from the access shafts into the station, creating 'bubbles' of fresh air for the passengers evacuating a stricken train

At the same time smoke or fouled air is sucked out through seven ventilation openings at the rate of 250 m<sup>3</sup>/sec. In the event of a fire, the powerful fans will ensure that the unaffected running tunnel is kept at a higher pressure than the bore where the fire is, to prevent the spread of smoke from one bore to the other.

Emergency lighting, signage and wide escape routes will also be provided. Once they have reached the safe haven, the passengers will be able to remain in a secure space within the multi-function station until they can be taken out of the tunnel by a rescue train.

Although both stations are accessible from the surface, via a network of shafts and adits which in each case is more than 6 km long, this does not form part of the evacuation strategy, which relies on the rail access.

**Operational safety**

Railway safety within the tunnel will be ensured by an array of train control and train management equipment. The latest generation of electronic interlockings will be used to control and monitor points and axle counters. Four interlockings and related equipment are being provided, one each at Rynächt and Bodio-Pollegio and one for each running tunnel.

A radio block centre forming the core of the ETCS Level 2 train control system will transmit movement authorities using GSM-R. The actual train operations will be managed by a dispatcher using SBB's standard ILTIS train monitoring system, which will be connected to an automated system developed specifically for the Gotthard Base Tunnel called TAG (Tunnel Automatik Gotthard).

This will be responsible for stopping the trains in the multi-function stations in the event of an emergency, for starting the ventilation system and turning on the lighting, and for halting any following trains clear of the incident. ⏪

# Ceneri Base Tunnel completes high-capacity corridor

**CONSTRUCTION** Rapid progress is being made with a second base tunnel forming an essential part of the project to create a high-performance north-south transit corridor.



**Dipl-Bauing ETH Wirschafting**  
**Walter Bernardi, FH**  
 Head of Tunnel Construction & Alignment  
 Ceneri Base Tunnel, AlpTransit Gotthard AG

After the Gotthard and Lötschberg base tunnels, the Ceneri Base Tunnel will be the third longest standard gauge tunnel in Switzerland. Only when it is finished in 2019 will the low-level high-capacity rail route through the Swiss Alps be complete.

The 15.4 km Ceneri Base Tunnel passes under Monte Ceneri, where the overburden reaches a depth of 800 m. The alignment was carefully chosen to suit the local geology and topological conditions, to reflect the concerns of the local population and to connect effectively with the SBB main lines at Camorino near Bellinzona and Vezia near Lugano.

The tunnel consists of two single-track bores whose track centres will be 40 m apart. At the northern end provision is being made for a future extension across the Magadino Plain forming part of a bypass round the town of Bellinzona. Caverns housing junctions at the southern end will allow for a future extension to be built towards Chiasso — these have been designed so that the extension can be built without interrupting rail services for lengthy periods.

**The southern portal at Vezia lies very close to existing houses.**

The choice of single-track bores and the decision to provide links to SBB's main lines serving both Bellinzona and Locarno at the northern end of the tunnel made it essential to excavate junction caverns close to the northern portal. The west to south connecting line, known as the Bretella, will in future allow direct trains between Locarno and the south, without passengers having to change at Bellinzona. This will ensure that regional services also benefit from the project.

As with the Gotthard Base Tunnel, safety has been designed into the Ceneri project from the outset. Cross-passages link the two bores at 325 m intervals and a ventilation room is being built at Sigirino to provide fresh air in an emergency. On the other hand, we do not envisage building a multi-function station, as the Ceneri Base Tunnel is much shorter.

However, emergency stations where passengers can leave a failed or damaged train are to be provided close to the northern and southern portals. Sites have also been reserved for railway equipment buildings adjacent to the portals, although detailed plans for these have yet to be agreed.

## Planning constraints

In planning the construction of the Ceneri Base Tunnel, the engineering design team had to allow for a shallow overburden in some locations. Other factors that influenced the plans included the presence of many houses close to the portals and the need to cross over or under main roads. This was the main reason for the decision to launch the main drives from Sigirino in the middle of the tunnel towards the northern and southern portals, where additional faces have been opened up to reduce the construction time. At both portals the construction methods have been chosen to reflect the sensitive nature of the areas.

Close to the northern portal the base tunnel alignment passes through a section of loose rock just 9 m

below the N2 motorway. At Nodo di Camorino a new four-track bridge is needed to carry the railway over the A2 motorway, while two single-track bridges are needed to cross a four-lane main road.

At the southern portal the two running tunnels pass above the new Vedeggio-Cassarate road tunnel, the difference in height between the two structures being just 4 m. During construction every precaution is being taken to ensure that there is no damage or disruption to these roads — which are owned by third parties. The phasing of work, the construction process and the choice of working methods have taken this into account.

As long ago as 1997-2000, a 3.1 km test bore was excavated at Sigirino to reach the alignment of the base tunnel. This provided valuable information about the geology that the miners could expect to find at the centre of the tunnel. We do not anticipate that the hard orthogneisses forming Monte Ceneri and the other gneisses along the alignment will be especially difficult to deal with. However, there are

to the SBB main line at Giubiasco is being built in the open. Two new reinforced concrete viaducts, one 1 000 m and the other 400 m long, will connect the tracks to the four-track bridge over the A2 motorway.

The rest of this section will be carried on an embankment. Here the ground is subject to settlement, with movements of up to 800 mm possible. To ensure that settlement does not occur during or after construction, preloading measures have been applied along the embankment alignment.

At the Sigirino construction site the first job was to build a village for the construction teams. Accommodation for 450 workers, a canteen, changing rooms, two offices and a visitor centre have been erected. As the major part of the excavation will take place from here, some of the most important work was to prepare storage areas for materials and for spoil disposal.

Buildings erected at Sigirino between 2007 and 2009 included the materials sorting tower next to the access gallery, storage silos

a conveyor belt and to allow construction machines to pass had to be cut. Built between September 2007 and November 2008, this 2.3 km long gallery has a diameter of 9.7 m. A TBM was used, partly because of the need to limit noise so close to the village of Sigirino.

The machine set out in March 2008, breaking through on November 6 2008 into the *Caverna Operativa* where the machinery for the main drive was being prepared. In October 2010 the concrete plant for the tunnel lining, which occupies the largest of seven caverns, went on stream. Excavation of the caverns took place at the same time as the TBM was cutting the gallery. By December 2010 the contractors had completed construction of the caverns and of a bypass tunnel.

Establishing a worksite at Vezia was very demanding. There were many constraints here because access was very difficult. In the immediate vicinity



**Left:** Aerial view of the Vigana-Camorino area at the northern end of the Ceneri Base Tunnel.

**Above:** Image showing the layout of roads and railways at Nodo di Camorino.

local outcrops of phylonite, mylonite, amphibolite schists and serpentinite. None of the rock is expected to have a high water content.

## Preparations

As with any tunnel project, some basic infrastructure has to be built before the main works can begin. Construction bases were established at Camorino, Sigirino and Vezia, and the first two required new roads to be built to connect to the cantonal trunk road network and the A2 motorway.

At Camorino near the northern portal substantial excavation was needed to complete the 500 000 m<sup>2</sup> site. Adjacent to the worksite the 2.7 km link

with rail access, conveyor belts and a facility for crushing stone to make cement. In 2008-09 the spoil from the access gallery and the logistics cavern was dealt with here.

The site chosen for final disposal of spoil has a capacity of 7.5 million tonnes or 3.5 million m<sup>3</sup>. In due course it will be grassed over to form part of a wildlife corridor which will include construction of a passage for animals to cross the railway at Dosso di Taverne. Work on this structure began in March 2011.

The Sigirino site will also accept most of the spoil from the workfaces at Vezia and Vigana.

Before the tunnelling work could start, a gallery wide enough to house

ity are SBB's Gotthard main line, the A2 motorway and the construction site for a new road tunnel being built as part of the local transport plan to form a bypass around Lugano, which is due to open at the end of 2011.

While all this preparatory work was in progress it was essential to protect the Villa Negroni, a listed historic building, and the southern portal of the base tunnel was therefore sited as far away as possible.

However, a preparatory cut had to be excavated as far as a datum level around 25 m below the Villa. The end of the cut was secured by a retaining wall, which was equipped with sensors to monitor any movement. Loose material was first removed from the



Work in progress at one of the faces at Sigirino in the centre of the Ceneri base tunnel.

top of the cut, and during summer 2009 the hard rock below was broken up with microcharges of explosive. Excavation was completed in autumn 2009.

**Work in progress**

The main contract for the Ceneri base tunnel was signed by AlpTransit Gotthard AG and a consortium of contractors on October 20 2009. Worth about SFr1bn at 2008 prices, the contract requires the two single track bores to be cut from the intermediate access at Sigirino. Two further consortia were contracted to open up faces at the northern and southern portals, and at the moment work is in progress at no less than 10 faces.

Conventional blasting is being used on all four faces at Sigirino. Once the external construction bases had been completed, the main contractor took over the underground sites on January 4 2010, paving the way for work on the main tunnel to begin in March. During the following summer conveyor belts for moving spoil to the disposal site at Sigirino

were completed in the main bores, the ventilation was installed and a concrete plant established in the *Caverna Operativa*. Blasting has been in progress at all four faces since September. Equipment supplies to the workfaces rely on suspended platforms, while excavated material is taken out by conveyor to Sigirino.

Once the tunnel shell has been completed, the main contractor is responsible for fitting out both running tunnels and for installing the ventilation equipment. Tracklaying and other railway equipment will be handled under a separate contract.

Work from the northern portal at Vigana demanded close co-operation with the Federal Roads Authority, and great care was needed because of the loose ground and the short vertical distance to the A2 motorway and SBB's main line.

Once the initial cuts had been made, the main drive began in June 2009. The tunnel for the single-track portal of the new Lugano – Bellinzona line was finished by May 2010, and work then started on the adjoining West Cavern.

For the double-track portal that will contain the new Bellinzona – Lugano track and the chord for the Lugano – Locarno line, the 20 m wide tunnel arch had first to be stabilised with horizontal jettings and pipe umbrella supports.

Excavation of the top layer of the tunnel had reached a length of 105 m by the end of

2010 with 56 m of the lower layer excavated.

This completed the drive in the area affected by the A2 motorway, allowing work to continue in the adjoining East Cavern. Working from the West Cavern, tunnellers cut a lateral access route to reach the alignment of the east running tunnel, so that by April 2011 workfaces on both the east and west running tunnels had progressed around 500 m into the mountain.

**Complexity at Camorino**

The construction teams moved on to the Nodo di Camorino site in 2006. Here a four-track structure will replace the existing double-track bridge over the A2 motorway. To avoid interrupting rail services, half of the new bridge is being erected alongside the existing one. The tracks will then be slewed onto the new bridge and the old structure dismantled to make way for the second half of the new bridge.

By June 2011 the abutments and piers for the first half had been completed and the reinforcing framework for the main girders was complete.

Nearby, the structure for the new bridge carrying the SBB tracks across the Morobbia valley was finished in October 2010. The central part of the excavation where the railway will pass below the cantonal main road is complete, and grading on the approach to the bridge from the Bellinzona direction is in progress.

April 2010 saw work begin north of the main road with the

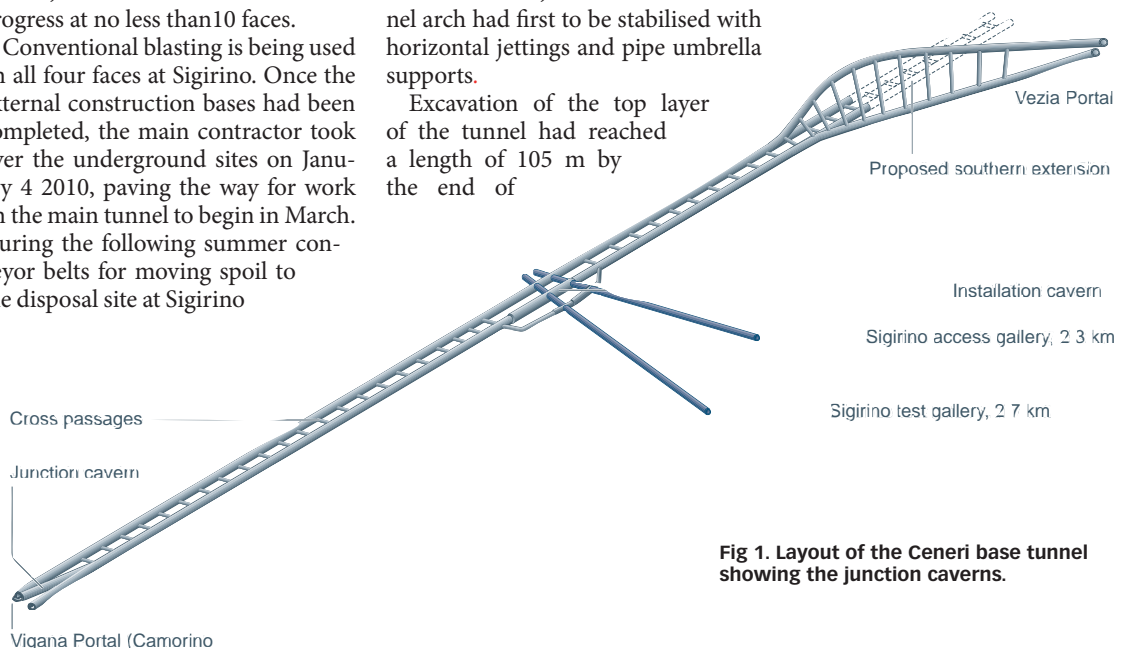

Fig 1. Layout of the Ceneri base tunnel showing the junction caverns.



dismantling of existing and temporary structures. A contract to build the 1 km viaduct on the Lugano – Bellinzona line was signed on December 16 2010 and work began on what will be the centrepiece of the Nodo di Camorino in early 2011. Construction of the 400 m long viaduct for the Bellinzona – Lugano track is due to commence in 2012.

## Southern portal works

To ensure that excavation of the running tunnel over the PTL road tunnel close to the southern portal at Vezia was complete before the road opened, a start was made on driving a 300 m section in the opposite direction in spring 2010. Progress was aided by favourable geology and co-operation from the local community, so that the point where the two tunnels cross was reached ahead of schedule in July 2010.

By the end of 2010 the drive had progressed beyond the critical area, and in April 2011 the 300 m top section for both single-track running tunnels was fully excavated. Around 200 m of the lower part of the tunnel has still to be excavated. Now in progress is a 170 m section of open



cut that will be covered over later.

Several structures are required for the next section, which runs in the open as far as the Massagno tunnel. These include a 650 m long retaining wall above the SBB main line as well as sound barriers. Being carried out in conjunction with SBB, this work is currently on schedule.

Construction of the Ceneri base tunnel will absorb around SFr2.5bn of the SFr12.3bn total cost of building the Gotthard low-level corridor. About SFr724m had been spent by the end of 2010 and contracts signed for the Ceneri Base Tunnel to date are together worth SFr2.1bn, keeping the project within budget. 

**The extensive construction site at Sigirino includes the main spoil disposal area.**

# Essential business information that gives you the edge



Print • Digital • Online

The Railway Gazette portfolio of publications provides the most comprehensive source of business information for the global rail industry.

The number one publication for the international rail industry



[www.railwaygazette.com](http://www.railwaygazette.com)

# Railway works start at the north portal

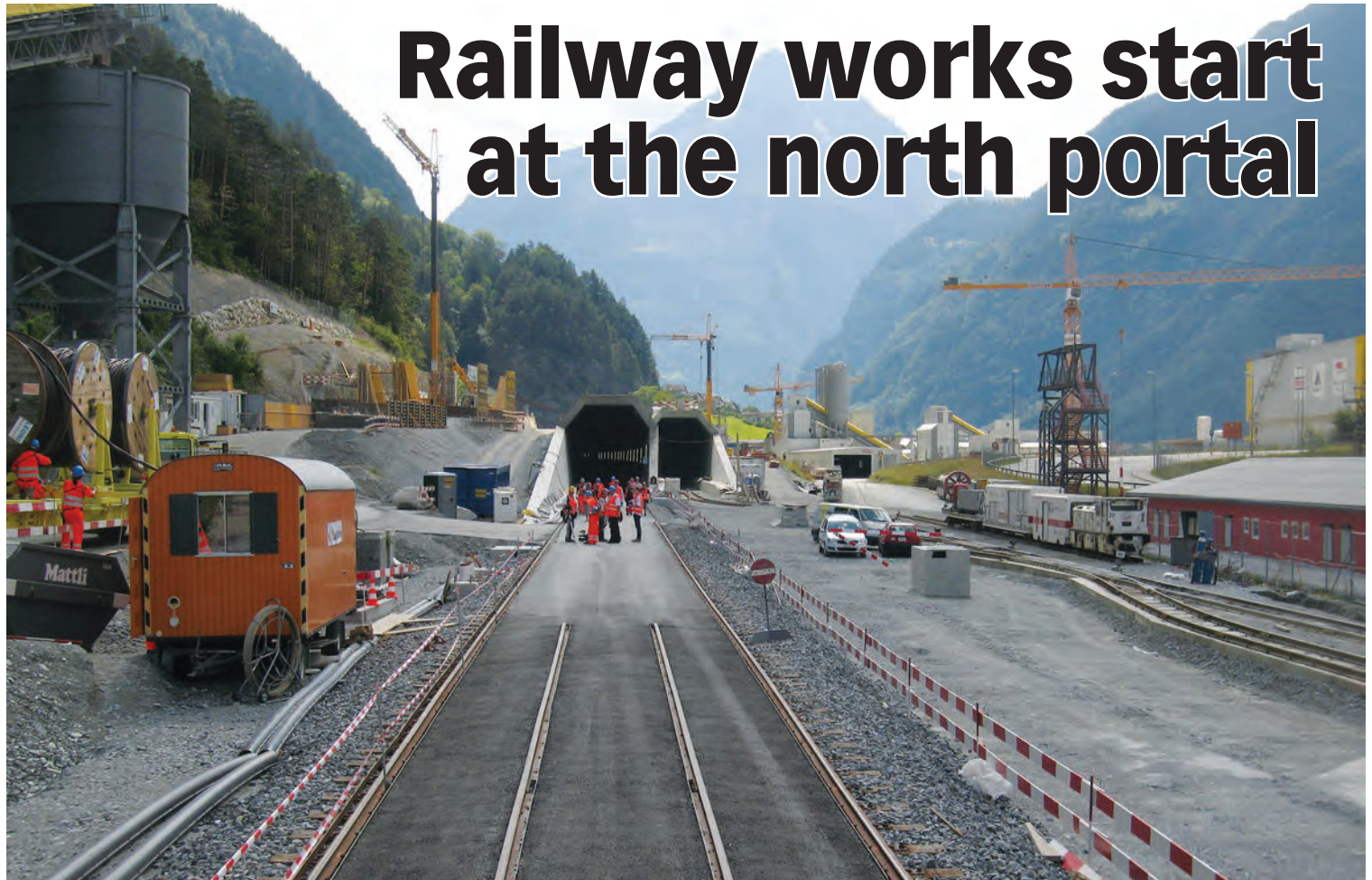

**COUNTDOWN** From October 1 AlpTransit Gotthard and Transtec Gotthard have 1 714 days left before they are due to hand over the 57 km Gotthard Base Tunnel to operator Swiss Federal Railways. Murray Hughes reports from Erstfeld.

On September 2 AlpTransit Gotthard and railway equipment contractor Transtec Gotthard launched railway installation works from the northern portal of the Gotthard Base Tunnel at Erstfeld.

The first railway equipment had been installed in the west running tunnel from the Bodio construction site at the southern portal in June 2010, allowing a 15.7 km section as far as the Faido multi-function station to be fitted out for testing well ahead of the rest of the tunnel. Track-laying on this section was completed on March 23 2011, the same day as the breakthrough in the west running tunnel (RG 5.11 p12). However, no further railway equipment can be installed from the southern portal at the moment as finishing works are still in progress. The railway installation teams have therefore moved north to the Erstfeld construction site. Here they are gearing up for an accelerated

programme of work as the tunnel's opening date has been brought forward by one year. Fitting out of the railway equipment room at Erstfeld begins this month.

Installation starts in the east running tunnel, working towards Amsteg and Sedrun Ost, and work in the west

running tunnel will follow early in 2012. With installation in full swing, more than 700 people will be active in the tunnel and at the portal worksite. For safety reasons, every worker is linked to a communications system that pinpoints their location in a control centre.



**Top:** Overview of the worksite at the north portal looking south from the current end of the approach tracks.

**Left:** Looking north from the portal of the east bore.

# ‘We are on target for opening in 2016’

**Renzo Simoni** Chairman, AlpTransit Gotthard AG

The plan to open the Base Tunnel in 2016 rather than 2017 was formally endorsed by the Swiss government on August 22, and the target date for opening is now December 16 2016, when Europe’s 2016-17 timetable will come into effect. A transport ministry statement confirmed that the earlier date was ‘realistic, achievable and sensible’.

Speaking in Erstfeld on September 2, Renzo Simoni, Chairman of Alp-Transit Gotthard AG, affirmed that he was ‘very confident’ that the deadline would be met, telling *Railway Gazette International* that very good progress had been made in the last two to three years. It was this that had made it possible to bring forward the opening. Tunnelling and finishing work



over the 7.5 km between Erstfeld and Amsteg had been completed nearly six months ahead of schedule, Simoni said, while time had been gained in one section by altering the length of a construction lot — which meant that one contractor gained work while

another lost it. Earlier setbacks had included a legal dispute, but ‘it’s all coming together now’, he said.

## Risks reduced

The biggest risks were faced during the tunnelling phase — and there were certainly several geological surprises (RG 7.11 p36). Now, with both running tunnels holed through and finishing works in progress, risk levels are significantly lower. Simoni described the finishing and railway installation works as ‘a form of industrial production’, which meant that the risks could be more easily assessed.

On the other hand, there was greater complexity, especially with the numerous interfaces between the different parties involved in the project. According to Rolf Brunner of Transtec Gotthard, more than 1 000 interfaces have to be managed. The process is not easy, not least because of the many different authorisation and approval procedures. Numerous sub-systems have to be proved to function correctly before work can be signed off.

## No leeway

Simoni made it clear on September 2 that the revised construction timetable left hardly any room for delays. This is why the rate of work for installing railway equipment has been

**Left:** The northern portals of the east and west bores are staggered to blend into the landscape of the valley north of Erstfeld.

After travelling to the portal by special train (below left), the inspection party was able to visit the east running tunnel (below), where cable installation work is already underway ahead of tracklaying.





stepped up. When tracklaying from the northern portal starts in the east running tunnel on February 2 2012, the work teams and equipment will be geared up so that 240 m to 250 m of track can be completed with each trip of the concrete laying train into the tunnel, rather than the 200 m to 220 m required when the train was working from Bodio. For this reason more materials wagons have been marshalled in the train.

The concrete train has its own building in Erstfeld; when it returns from two shifts working in the Base Tunnel, the third shift of the day is spent cleaning the vehicles thoroughly and replenishing them with materials for the next day's tracklaying. A full description of the tracklaying process was published in RG 7.11 p44.

**Pipe problem**

Simoni highlights one area of concern. This relates to the relatively complex tunnel drainage system in which water flowing in from the surrounding rock must be kept separate from any foul water in the running tunnels, which could be contaminated with oil or other pollutants.

It turns out that some pipes of high-density polyurethane were supplied using recycled material, contrary to the specification. This is likely to affect the life of the pipes, but the issue now is to determine precisely what effect it will have. A specialist testing institute has been appointed to undertake the work, which involves 20 different tests. Simoni says that 10 000 h of testing will be needed to ascertain the extent to which the life of the piping will be affected, and only in the middle of 2012 will the answer be known. Until then no decision can be taken about what to do.

**Two 25 m long 'multi-function machines' were developed by Alpiq Burkhalter Bahntechnik specially for work in the Gotthard Base Tunnel. Able to handle loads of up to 20 tonnes, they are initially being used for cable laying, with as much as 7.5 km of cable installed in a single shift. No less than 3 200 km of copper cable and 2 600 km of optic fibre cable are required.**

At the moment there is no question of removing the affected pipes — at most about 200 km out of 456 km — and there is no danger that they will not perform as required. It is only their life which is in question.

**Handover**

All the work being undertaken by AlpTransit Gotthard and Transtec Gotthard is now geared towards the key date of May 31 2016. That is the day when the tunnel contractor must hand over responsibility to the operator, SBB. The date falls right in the middle of the commissioning phase, and a distinction is made between tests carried out before the handover and those scheduled to take place under SBB's responsibility.

Tests before the handover cover the functions, processes and integration of all the equipment in the running tunnels and cross-passages. After the handover the tests are in effect practice runs for the launch of commercial services. They will include staff familiarisation and simulation of a range of scenarios that introduce equipment failures or malfunctions. If all goes to plan, SBB envisages running a limited service of commercial trains through the Base Tunnel before the full opening, as happened with the Lötschberg Base Tunnel.

Railway equipment installation manager Oliver Bratschi told visitors last month that it is already possible



for a train to run through the tunnel — but only in the laboratory. This foreshadows the start of full-scale running trials on the Bodio – Faido West test section in December 2013, with trains running at up to 230 km/h. After that, the running tunnels will be released for testing section by section, with the entire Base Tunnel available for trains to run through at up to 280 km/h by October 2015. Once the two bores are open, passenger trains will run through the tunnel at 250 km/h using Level 2 ETCS. No back-up colourlight signals will be provided.

**Getting ready**

Preparations for opening cover a wide range of measures, including changes to the way in which international passenger services to and from Italy are managed. SBB has been far from happy with the performance of the ETR470 tilting trainsets that have

**Table I. Railway equipment contractors**

Overall contractor and project manager	Arbeitsgemeinschaft Transtec Gotthard (Alpiq InTec, Alcatel-Lucent/Thales RSS, Alpine Bau, Balfour Beatty Rail)
Track	Balfour Beatty Rail, Alpine Bau
Traction power supply (15 kV 16.7 Hz)	Balfour Beatty Rail Kummler & Matter
Tunnel power supply at 50 Hz (16 kV, 600 V, 400 V)	Alpiq Burkhalter Bahntechnik
Telecoms and safety equipment	Alcatel-Lucent Schweiz Thales RSS



Leading the 500 m long concrete train is the pump wagon, followed by 'Helvetia', the machine at the heart of the concrete train that mixes the materials for the track slab laid in the tunnel.

operated trains from Zürich and Genève to Milano since the mid-1990s. Their ETR610 replacements were delivered late and reliability of the two types is still a problem, forcing SBB to substitute conventional rolling stock for domestic journeys. Indeed, this happened during your writer's journey from Basel to Erstfeld on September 2.

The cost of maintaining the ETR470 fleet in service is high, and SBB decided earlier this year that the four sets in its ownership following the demise of the SBB-Trenitalia Cisalpino subsidiary will be withdrawn by the end of 2014.

This is the background to a decision by SBB to call tenders by December this year for a new fleet of trains specifically to operate services through the Gotthard Base Tunnel. SBB aims to have these operational by December 2016.

In the meantime SBB is taking steps to improve service quality, signing the so-called *Accordo dei Castelli* with Italian Railways in Bellinzona on August 6. This committed the two railways to make improvements to both local and long-distance cross-border services for the World Expo being staged in Milano in 2015, and it is clear

that the improvements are intended as a prelude to faster and better services through the Gotthard Base Tunnel. A definitive time table for passenger trains will be agreed two years ahead of the opening, in 2014.

With transit time through the Base Tunnel taking just 12 to 15 min, journey times from Zürich to Milano will come down to 2 h 50 min, with 2 h 40 min envisaged once the Ceneri Base Tunnel is open in 2019. Zürich – Lugano timings will be slashed to 1 h 40 min compared with about 2 h 40 min now.

Work on the Ceneri base tunnel is well in hand with 13.96 km out of 39.78 km of tunnelling complete. However, some sectors are behind schedule by three to five months. Despite this, the current rate of progress is good, and the hope is that the delay will be made up.

Simoni expects that tenders for railway installation works in the Ceneri will be called in 2012; as with the Gotthard Base Tunnel, the plan is to appoint a general contractor.

#### Still in budget

In terms of cost, Simoni reckons that the Gotthard Base Tunnel budget of SFr13.157bn at 1998 prices, excluding VAT and inflation, will be met. On the other hand, AlpTransit Gotthard's focus is to minimise the investment cost, whereas its parent company SBB is anxious to ensure that life-cycle costs are kept to a minimum. This generates an interesting conflict of interest, Simoni suggests. ◀



The concrete train spends two shifts in the tunnel. During the third shift it returns to the base at Erstfeld for a thorough clean before reloading. Facilities at Erstfeld include the cleaning and loading plant (left). About four or five days of material will be stocked on site to keep the train replenished.

Subscribe today and **save 20%\***

[www.railwaygazette.com/subs112](http://www.railwaygazette.com/subs112)



# Stay ahead. Stay informed. Subscribe today.

**The number one publication for the international rail industry**

Railway Gazette International is the monthly news magazine serving the global rail market. With more than 170 years of editorial excellence, every issue provides readers with the latest news, features, analysis and technical information from the heart of the rail industry.

Subscribers  
to Railway Gazette  
International receive  
these exceptional benefits

- **Issues delivered direct** to your home or office
- **Continuous Service** † – you can cancel your subscription whenever you like (minimum six issues)
- **Discount** – subscribe today and save 20% off the normal rate\*
- **Digital Issue** – free of charge, with access to our digital archive
- **Our Guarantee** – if you're not happy with your subscription, we'll refund the remaining issues to you

# Railway Gazette

INTERNATIONAL

# Is Switzerland's transit freight policy working?



PHOTO: SBB

**MODAL TRANSFER** With the Gotthard Base Tunnel due to open in December 2016, rail should be set to shoulder the burden of transit freight through Switzerland, removing many lorries from the Alpine roads. Now plans for a second Gotthard motorway tunnel are clouding the issue. Murray Hughes reports.

Unaccompanied intermodal traffic dominates in transalpine rail freight, but rolling motorway services are politically important in the drive to switch cargo from road to rail.

Enshrined in Swiss law is a commitment to limit the number of lorries carrying transit freight through the Swiss alps. This dates from the so-called 'Alps Initiative' in February 1994, when a majority vote in a national referendum called for a ban on transit lorries from 2004. It did not quite work out like that, but the plebiscite did lead to amendments to the Swiss constitution requiring the government to introduce measures restricting the number of lorries transiting Switzerland between Germany and Italy. The vote also served as the starting pistol for simultaneous construction of the Lötschberg and Gotthard Base Tunnels in the ambitious AlpTransit project.

The Lötschberg Base Tunnel opened in 2007, but so far there is little sign of the tide of lorries abating, prompting questions about the

efficacy of the government's policy. In particular, the Swiss are anxious to know if the 57 km Gotthard Base Tunnel, now due to open in December 2016 (RG 7.11 p36), will achieve the desired effect of switching freight from road to rail.

## Target missed

The legislation requires the number of lorry transit trips per year to be cut to 650 000 within two years of the Gotthard Base Tunnel opening. An intermediate target of 1 million lorry trips was set for 2011, but the actual figure turned out to be significantly higher at 1.25 million.

Environmentalists have seized on this to attack the government's strategy, but the Federal Transport Office's response has been to point out that, had the existing restrictions not been in place, transit lorry traffic would

have been higher still — in December 2011 the ministry estimated that there would be from 650 000 to 700 000 additional lorries a year driving through the Swiss Alps.

## Road share up in 2012

In 2012 rail and road freight traffic transiting Switzerland fell from a combined total of over 40 million net tonnes in 2011 to 37.5 million, a drop of 6.4%. Rail traffic was down by 7.5% and road by 4.5%, with the proportion moving by rail slipping from 64.1% to 63%.

Some of this was the result of the downturn in the European economy, with Italian industry being particularly badly hit; this translated directly to lower levels of transit traffic. Other contributory factors were strikes in Italy and in the Belgian port of Antwerpen, leading to many freight trains being cancelled.

The figures were further skewed by the closure of the Gotthard main line from June 5 to July 2 following a serious rockfall at Gurtellen. This occurred at almost the same location as a landslide on March 7 2012 which



**'The second [road] tunnel is the most sensible solution'**

**Doris Leuthard** Transport Minister, Switzerland



had closed the line for three days. Not only that, but the Simplon main line was closed from August 11 to September 2 because of repair work in the Varzo spiral tunnel on the southern approach to the Simplon tunnel.

During closure of the Gotthard route, some of the traffic was diverted over the Lötschberg main line, with up to 25 extra trains a day being handled, albeit with severe delays in some cases, but between 10 and 20% of traffic diverted to other routes outside Switzerland, much of it using the Brenner motorway. Other traffic switched to road, generating about 540 extra transit lorries a day.

Other influences on 2012 traffic levels were a derailment on the southern approach to the Simplon tunnel early in the year, leading to short-term closures and long-term speed restrictions that reduced capacity.

In Austria, the busy rail route through the Brenner pass was closed for a month in August 2012 for a €55m renovation programme, with single line working restricting traffic in June, July and September and some weekend closures. This too may have affected the number of lorries using the Swiss transit routes.

## Second Gotthard road tunnel

With rail traffic vulnerable to events such as the Gurtellen rockfall, the timing of the Swiss government's announcement on June 27 2012 that it favoured construction of a second Gotthard motorway tunnel was unfortunate, to say the least.

The issue stems from the need to modernise and renovate the existing 16.9 km Gotthard road tunnel, which means closing

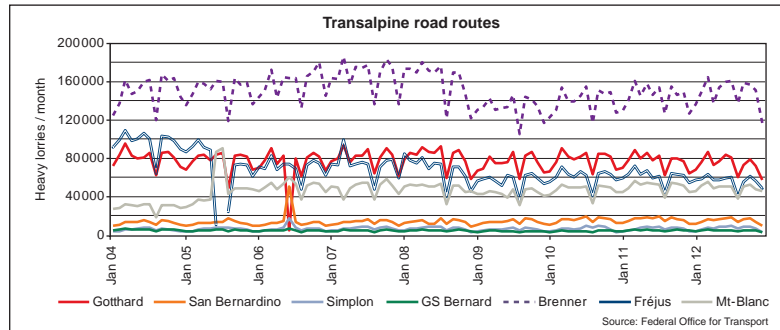

Fig 1a. Transit road freight through the Alps in 2004-12 shows the predominance of the Brenner route through Austria.

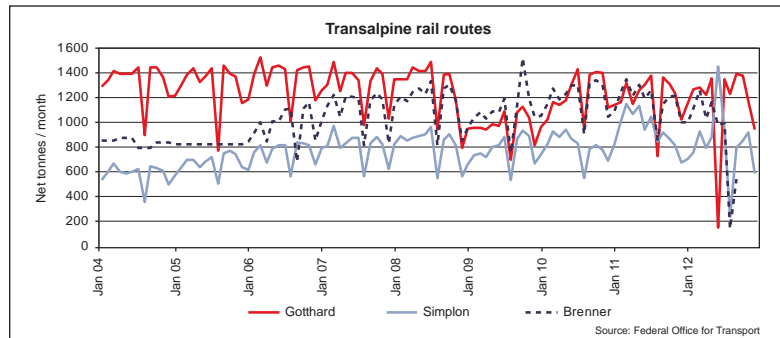

Fig 1b. The Gotthard is the dominant Alpine transit route in the rail sector. The problems in 2012 are clearly evident.

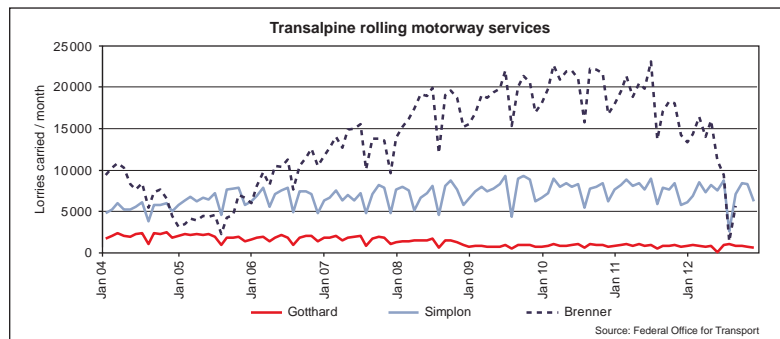

Fig 1c. The Brenner carries more rolling motorway traffic through the Alps than the Swiss transit routes.

it for two and half years while the work is carried out. Investigations into ways of keeping traffic flowing concluded that 'the most sensible solution' — to quote Transport Minister Doris Leuthard — was to build a second road tunnel at a cost of SFr2.8bn,

although it is not clear where the money will come from. After a long period when this option had been out of favour, the Federal Transport Office reversed its opinion and decided to back a second bore. This move unleashed a fierce debate.

Environmentalists were quick to object that a second road tunnel would increase capacity for lorries and attract more road freight. Leuthard counters this with the argument that when — or if — the second tunnel is built, the two tunnels would operate with a single lane in each, which means that there would be no increase in capacity.

Opponents point out that this policy could easily be changed so that two carriageways are available in each bore, but the ministry says that it will legislate so that the number of lanes cannot be increased, even during peak holiday periods. It also insists that this will bring about a major improvement in safety, eliminating once and for all the possibility of head-on



Tracklaying in the Gotthard Base Tunnel is now well advanced, and test running at up to 230 km/h is scheduled for the end of this year.



Photo: SBB

230 km/h is due to start on the 16 km between Faido and the southern portal at Bodio in December.

In the Ceneri Base Tunnel, about 60% of the 40 km of bores required has been excavated, and AlpTransit Gotthard is confident that the tunnel will be fit for trains to run in 2019.

**4 m corridor**

There had been a tacit understanding that opening of the Gotthard Base Tunnel would be accompanied by infrastructure improvements to allow 4 m high lorries to be carried on freight wagons on the northern and southern approaches to the base tunnel — where numerous shorter tunnels and other obstacles restrict clearances so that only 3-8 m high lorries can be carried. In practice, progress on developing a 4 m corridor has been very slow, but in December 2011, prompted by the intermediate target for lorry transits being missed, the government made a renewed commitment to complete the work required in time for opening of the Ceneri Base Tunnel.

Based on studies carried out by SBB, the SFr710m programme — to be paid out of the Finöv public transport infrastructure fund — will buy clearance improvements all the way from Basel in the north to Chiasso and Ranzo in the south; Ranzo is on the line from Bellinzona to Luino, which gives access to Novara, Gallarate and Busto Arsizio.

The Swiss government has gone even further. Dr Peter Füglistaler, Director of the Federal Office for Transport, wrote in these pages (RG 7.11 p32) that the Swiss policy of switching freight from road to rail would only work if Germany and Italy made commitments to improve their approach routes too.

While some progress has been made in both countries, the pace has been slow. In an effort to accelerate

collisions with traffic in the same bore travelling in both directions.

**Safety concerns**

Safety in the 16.9 km road tunnel has been a hot topic ever since a collision between two lorries on October 24 2001 led to a fire in which 11 people died. Additional safety measures were introduced after the fire, including enforcement of a 150 m gap between lorries entering the tunnel. Nevertheless, from 2002 to 2011 there were six deaths and about 70 injuries caused by accidents; another incident last December killed one motorist and injured another.

As arguments continue to rage, it seems that the issue of the second road tunnel may be put to a referendum in 2015. If the vote is in favour, a start could be made in 2020, with 2027 seen as the earliest completion date. Adding on the time needed for renovation of the existing tunnel means that that the two road bores would be fully operational around 2030.

SBB weighed into the debate on April 22, stating that construction of

a second Gotthard road tunnel would only be acceptable if there were a firm commitment not to increase capacity. The operator believes that the Gotthard and Ceneri Base Tunnels will open up further market opportunities for rail, but it noted that experience showed that switching traffic from road to rail was only possible if limits were placed on road transit capacity.

An alternative to building a second road tunnel would be a rail shuttle service for road vehicles, similar to Euro-tunnel's operation through the Channel Tunnel. Grounds for rejecting this option include insufficient capacity and the cost of building shuttle terminals that would become redundant as soon as the new road tunnel was completed.

**Base tunnel progress**

Rapid progress is meanwhile being made with the Gotthard Base Tunnel, with AlpTransit Gotthard reporting on April 2 that more than 40% of railway equipment had been installed. Slab track has now been laid in both bores over the 20 km between Erstfeld and Sedrun, and test running at up to

**SBB Cargo will take over from BLS Cargo as DB Schenker Rail's partner on the Gotthard route from next December.**

**Table I. Swiss transit traffic, 000 net tonnes**

	2011	2012
Road	14 483	13 835
Rail	25 627	23 714
Wagonload Gotthard	5 000	4 308
Wagonload Simplon	2 683	2 550
Gotthard unaccompanied intermodal	9 177	9 414
Simplon unaccompanied intermodal	6 787	5 846
Gotthard rolling motorway	182	151
Simplon rolling motorway	1 619	1 446

Source: Federal Office for Transport

BLS celebrates its centenary this month, with special events in Frutigen on June 29-30 to commemorate the first trip through the original Lötschberg tunnel on June 28 1913.

work in Italy, Doris Leuthard and Italian Transport Minister Corrado Passera signed a Memorandum of Understanding in Bern on December 17 2012 which provides for the Swiss government to make SFr230m available for clearance improvements on the lines from Chiasso to Milano and Ranzo to Gallarate. This will be an important step towards the objective of completing a 4 m corridor all the way from Rotterdam to Milano.



Photo: BLS Cargo

**Base tunnel effect**

In an effort to gauge the effectiveness of the Gotthard Base Tunnel in achieving its policy objectives, the Federal Office for Transport commissioned a study into the likely impact after opening. Published in May last year, the study also looked at the effects of completing the 4 m high corridor through Switzerland. A model was created to calculate likely improvements in productivity, capacity and transport quality.

Noting that opening of the Gotthard and Ceneri base tunnels will shorten the distance through Switzerland by 30 km and offer time savings of 60 min, the study reported that the number of paths will rise from 180 to 252, taking both directions together. Railway operating costs will fall by 30%, with staff costs dropping by 35%. Energy cost savings are put at 10%. Taking these together, the study concluded that average cost for unaccompanied piggyback traffic would fall by 9%, with quality improvements reducing costs by a further 10% to 20%.

Completion of the 4 m corridor is expected to bring savings of about 20%, which the study says would 'in purely

Seen here on test at Kandersteg, the first of three Bombardier Class 187 'last-mile' locomotives will enter service with BLS Cargo next year.

mathematical terms' generate more benefit than building the base tunnel.

The authors concluded that the Gotthard Base Tunnel will lead to a 59% increase in unaccompanied intermodal consignments over current levels without the 4 m corridor. If the 4 m corridor is included, then the figure rises to 98% by 2030.

However, the model showed that 'the infrastructure-related measures alone can reduce the number of heavy vehicles compared to a situation without the AlpTransit project by up to 200 000 trips.' Although this reduces the growth in lorry traffic, the number of lorries will still rise, and 'the traffic transfer objective, which is enshrined in law, can therefore not be achieved.'

**Scene is changing**

In the meantime the freight scene on the Gotthard is about to change. With effect from December, BLS Cargo, which is 45% owned by Deutsche Bahn, will no longer handle DB Schenker Rail's transit freight over the

route (RG 5.13 p12). CEO of BLS Cargo Dirk Stahl says that 'we have to exist in a heavily contested market and we have to finance our own business. That's why we have to work towards a profit. Our aim is to balance the books this year, returning to the black for the long term.'

Traffic routed over the Gotthard makes up around 26% of BLS Cargo's business, and after the collapse of negotiations with DB Stahl insisted that 'we were not prepared to put in a bid which would not cover its costs for a number of years.' Nevertheless, Stahl said that 'we will offer a full service on both transit corridors in the future, and we will be putting new structures in place as part of our preparations for the start of operations through the Gotthard Base Tunnel.'

Next year BLS Cargo will commission three electric locomotives with a 'last mile' diesel engine. Being leased from Railpool, these Class 187 locomotives from Bombardier 'will allow BLS Cargo to tap new markets in private siding traffic', said Stahl.

A BLS Cargo container train hurries through Airolo. The company intends to maintain 'a full service' on the Gotthard, despite losing the DB Schenker Rail contract.

**Table II. Percentage share of Swiss transit rail freight handled by different rail operators in 2012**

	Gotthard	Simplon	Total
SBB Cargo International	42.4	8.0	28.1
SBB Cargo	17.6	7.0	13.2
BLS Cargo	25.8	59.1	39.6
Crossrail	4.4	25.2	13.0
TX Logistik	4.0	0.3	2.5
Transalpin	2.9	0.4	1.9
DB Schenker Rail CH	2.8	0.0	1.7
<b>Total</b>	<b>100</b>	<b>100</b>	<b>100</b>



Photo: Dominic Wyss

## Competition winner



**AUSTRALIA:** Hassell, Herzog & de Meuron and heritage consultant Purcell have won a A\$1m design competition for the redevelopment of Melbourne's Flinders Street station, with support from Arup, Thiess, Equiset, RLB and Jarlo Visions. The station would become a new civic precinct with an art gallery, plaza, amphitheatre, market and home for cultural organisations.

'The weatherproof, articulated filigree vaulted roofscape is a respectful yet dynamic interpretation and contextual response to the history, function and location of this very special place in the heart of Melbourne,' said Ascan Mergenthaler of Herzog & de Meuron. ↩

## CONTRACTS

**CANADA:** Nomad Digital has completed the roll-out of wi-fi on VIA Rail's Ocean service.

**CHINA:** Siemens has won a €25m contract to supply communications including the Controlguide station management system for Hong Kong's Shatin – Central Link.

**FRANCE:** SNCF has awarded a joint venture of Newrest (65%) and Elior (35%) a contract to provide catering from November on domestic TGV services, *Intercité* trains on the conventional network and international services on LGV Est operated by SNCF/DB joint venture Alleo.

**POLAND:** Zachodniopomorskie voivodship has awarded a consortium of Trako and Refunda a 600 000m złoty contract to develop a regional transport plan running to 2025.

**RUSSIA:** Sole bidder Maksima-Telekom has been selected to install wi-fi on the Moscow metro.

## INFRASTRUCTURE

**ALGERIA:** Siemens has won a €20m contract to supply Trainguard MT communications-based train control for the extension of Alger metro Line 1.

**AUSTRIA:** ÖBB Infrastruktur has awarded Powerlines an €8.3m contract to undertake electrification works for the Wien Hauptbahnhof project.

**BELGIUM:** Infrabel has awarded ETF Luxembourg and Cegelec a €15m resig-nalling contract including replacement of PTAR with PLP signalling at signalboxes in La Louvière, Manage, Ecaussines, Gouy-lez-Piéton and Feluy.

**FINLAND:** Länsimetro has awarded Skanska a €37.5m contract to build Keilaniemi metro station in Espoo.

**LITHUANIA:** LG has awarded Eurovia CS and Eurovia Lietuva a contract to upgrade the 18.5 km Kazlu Ruda – Mauruciai route for Rail Baltica (p10).

**NETHERLANDS:** Strukton Rail has been awarded a contract to maintain the Utrecht *snelttram* line for five years from December 1. It has also been selected to modernise track and overhead line equipment at Zichtenburg tram depot in Den Haag.

**NORWAY:** Skanska has won a Nkr532m contract to extend the Bergen Bybanen tram line to Flesland airport.

**POLAND:** PKP PLK has awarded Porr a 39.8m złoty contract for track renewal on 24 km of the Poznań – Szczecin line, and Eurovia a 17.5m złoty contract to modernise track, signalling and electrification on the 9 km Jaworzyna Śląska – Świebodzice section of the Wrocław – Wałbrzych line.

Gotowski has won a 290m złoty contract to build a 9.5 km tram line serving the Fordon area of Bydgoszcz, with 14 stops and three turning loops.

SKM w Trójmieście has awarded Rajbud and Dekpol an 80m złoty contract to build Gdansk Śródmieście station by the end of 2014; running suburban services through to this new terminus will help to increase capacity at Gdansk Główny.

**QATAR:** Qatar Rail has appointed Jacobs Engineering to provide project management for the Doha Red Line.

**SAUDI ARABIA:** Tata Steel's Scunthorpe and Hayange plants are to supply 60 000 tonnes of rail for the Haramain High Speed Rail project.

**SINGAPORE:** LTA has awarded Samsung C&T Corp a S\$285m contract for the construction of Caldecott metro station and associated tunnels. A separate S\$421m contract was awarded to Shanghai Tunnel Engineering Co for the construction of 7 km of twin tunnels on the Thomson Line.

**SPAIN:** ADIF has awarded Azvi a €8.15m contract for track renewals on the 20.8 km Almoraima – Algeciras route, raising speeds to 160 km/h with provision for future electrification.

**SWEDEN:** Trafikverket has awarded Strukton Rail a €80m contract to maintain the 680 track-km northern section of the Södra Stambanan route for five years from May 2014, with an option for a two-year extension. Strukton Rail has a separate contract covering the southern 430 track-km.

**SWITZERLAND:** AlpTransit has awarded the SFr138m railway systems contract for the 15.4 km Ceneri base tunnel to the CPC consortium of Calex, Porr Suisse, Porr Bau, Condotte, Cossi and LGV. The SFr96.4m track contract has been awarded to the Mons Ceneris consortium of Mancini & Marti, Marti Contractors, Marti Tunnelbau, Pizzarotti, GCF and Valditerra Lavori Ferroviari.

**TURKEY:** A Yapı Merkezi Construction/Yapıray joint venture has won a YTL53.8m contract to extend the Konya tramway from Alaaddin Tepesi to Adliye Sarayı by August 2015.

**UK:** Network Rail has awarded Telent a contract to replace Radio Electronic Token Block base stations on the Far North and West Highland Lines.

**USA:** Promoter M-1 Rail Corp has selected Stacy & Witbeck as general contractor for the 5.3 km Detroit streetcar project (RG 3.13 p15).

**VIETNAM:** ETF and local subcontractors are to modernise a 35 km section of the metre-gauge Hanoi – Lao Cai route, including three stations and construction of a bridge.

Posco Engineering & Construction has won a US\$73m contract to build eight light rail stops in Hanoi.

# Railway Directory

## Your Indispensable Reference Source for the Global Railway Industry

Completely updated, the *Railway Directory 2016* is the industry's most accurate and comprehensive source of global rail data. Also available in both print and online formats, it remains the first port of call for rail professionals, with over 22,500 key industry contacts, information on the latest urban / global rail projects\*\*, country and project profiles\*\*, over 190 colour maps and a comprehensive Buyers' Guide.

Published in two main sections – Railway Operators and Suppliers – *Railway Directory 2016* is clearly indexed, listed alphabetically and very easy to navigate. **Content includes:**

### Railway Operators

- ✓ Who's Who Key contacts and addresses worldwide
- ✓ Associations
- ✓ Regulatory Authorities
- ✓ Railway/Train Operators
- ✓ City Railways

### Suppliers

- ✓ Rolling Stock
- ✓ Rolling Stock Components
- ✓ Traction & Control
- ✓ Infrastructure A-Z
- ✓ Data & Information Systems
- ✓ Consultants/Support Services

Four ways to purchase	Please tick	£	€	US\$
Licensed version	Please call for more details			
Printed Directory Only	<input type="checkbox"/>	370	490	640
Web Only	<input type="checkbox"/>	400	530	705
Printed Directory and Web	<input type="checkbox"/>	525	640	990

### Your details

Title: \_\_\_\_\_ Initial: \_\_\_\_\_ Surname: \_\_\_\_\_  
Job Title: \_\_\_\_\_  
Company Name: \_\_\_\_\_  
Address: \_\_\_\_\_  
\_\_\_\_\_  
Post/Zip Code: \_\_\_\_\_  
Country: \_\_\_\_\_  
Tel: \_\_\_\_\_  
Email: \_\_\_\_\_

### Four payment options

- 1 Complete our online form at [www.railwaydirectory.net](http://www.railwaydirectory.net)
- 2 By Cheque: I enclose a cheque made payable to **DWV Media UK Ltd** for  £  €  US\$ Amount: \_\_\_\_\_
- 3 By Card: Please debit my  Visa  Amex  Mastercard  Switch for  £  €  US\$ Amount: \_\_\_\_\_  
Card No:                  
Issue No:    (Switch only)  
Valid from:    Expiry date:
- 4 Please invoice  me  my company.  
Order Number: \_\_\_\_\_  
Are you registered for VAT?  Yes  No  
VAT Registration No: \_\_\_\_\_

Please return to: **Railway Gazette International Subscriptions, DWV Media UK Ltd, 7th Floor, Chancery House, Sutton, Surrey, SM1 1JB, United Kingdom.**  
For our Privacy Policy, please go to [www.railwaydirectory.net](http://www.railwaydirectory.net) \*Includes data export of a maximum of 300 companies. \*\*Exclusive – Railway Directory Online now includes new and enhanced country and city profiles, plus the most comprehensive details of the latest urban rail project updates from around the world.



Your entire company can have full access to the *Railway Directory* and data with just one annual licence fee payment\*.

For more information, contact Sheena Rennie on +44 20 8652 5211 or email [sheena.ennie@railwaygazette.com](mailto:sheena.ennie@railwaygazette.com)

## Base Tunnel countdown



Photo: AlpTransit Gotthard Ltd

**SWITZERLAND:** The Gotthard Base Tunnel is to be inaugurated during the first week of June 2016, Transport Minister Doris Leuthard announced as she launched the first official test train through a completed section on December 16.

Leuthard was accompanied by Swiss Federal Railways CEO Andreas Meyer and AlpTransit Chairman Renzo Simoni during a trip on a Tilo Class 524 Flirt EMU running at 160 km/h. Trials are being conducted in the 13 km section of the west bore between the southern portal and the multifunction station at Faïdo, which has been completely fitted out. Tests are to take place on around 100 days over the next six months to ensure that AlpTransit can hand over the tunnel to SBB in full working order. SBB would then have six months to conduct its own tests before the start of public services at the end of that year. ❏

## CONTRACTS

**FINLAND:** VR is to use Quintiq software supplied through distributor Ab Ovo for locomotive planning and dispatching.

**POLAND:** PKP Cargo has signed a 1.3bn zloty contract for PKP Energetyka to supply traction energy until December 2016.

PKP IC has selected Kraft to develop apps for tablet computers it plans to procure this year for use by 1 900 on-train staff.

**SWEDEN:** Artron is to supply ticket vending machines for eight ÖstgötaTrafiken EMUs.

**UK:** Nomad Digital is to roll-out free wi-fi on First Great Western's inter-city and sleeper trains between May and the end of 2014.

Hitachi Rail Europe has appointed Capgemini UK to provide IT support for its future Newton Aycliffe rolling stock plant and maintenance facilities.

## INFRASTRUCTURE

**AUSTRALIA:** Thiess has selected a joint venture of AECOM and Aurecon Design to provide design services for the Moreton Bay Rail project.

**BELARUS:** China National Electric Import & Export Corp beat four other international bidders for a contract to electrify the line from Maladzyechna to the Lithuanian border, with 85% of the US\$90m cost to be met by loans.

**FRANCE:** A consortium of Colas Midi Méditerranée, Colas Rail, Bouygues TP and Soletanche Bachy has been awarded an €18.3m contract to build an extension of Marseille tram Line 2 from Canebière to Castellane.

**GERMANY:** Rhombeg Bahntechnik has won three contracts totalling €19.2m to supply electrical equipment for 107 km of the Nürnberg – Erfurt – Leipzig/Halle – Berlin corridor.

**HUNGARY:** NISZ has awarded Kapsch CarrierCom and infrastructure works partner MVM OVIT a €46m contract to install GSM-R on 900 km of the network by the end of 2015. Kapsch will maintain the equipment for three years.

Thales and local partner Dunántuli have won a €80m contract 85% financed by the EU to provide ETCS Level 1 and 2 for the 70 km Gyoma – Békéscsaba – Lókösháza route.

**INDIA:** On November 22 Terratec delivered the last two of eight tunnel boring machines ordered in 2012 for Phase III of the Delhi metro.

**ITALY:** Railway authority ARST has awarded a consortium of Alstom (€25m) and civils contractor Gemmo (€8m) a contract to supply signalling systems including Smartlock interlockings and Iconis controls for the 44 km Monserrato – Senorbi and 57.8 km Macomèr – Nuoro 950 mm gauge routes in Sardinia by 2015.

**LIBYA:** Ansaldo STS has returned €41m of the €71m advance payments made by Russian Railways' ZST business for a €202m subcontract to provide signalling for the 554 km Surt - Banghazi line. Force majeure clauses were activated when construction was stopped by the civil war, although Ansaldo STS says Libyan Railways

intends 'to resume the work as soon as practicable.'

**MAURITANIA:** SNIM has awarded Metso and Ferrostaal a contract to build an automated iron ore wagon dumper at the port of Nouadhibou.

**POLAND:** PKP PLK has signed an agreement running to 2016 for rail materials to be tested at 16 motorway authority laboratories.

PKP PLK has awarded PRK Kraków a 25.7m zloty contract to replace 46 km of track between Koniecpol and Częstochowa Stradom by the end of November 2014.

**SAUDI ARABIA:** Vossloh Fastening Systems has won a €30m contract to supply rail fastenings for the 444 km Haramain High Speed Rail project.

**SINGAPORE:** Land Transport Authority has awarded a S\$337m contract to Penta-Ocean Construction Co for the construction of Woodlands North station on the Thomson Line, and a S\$189m contract to Sinohydro Corp for the construction of Napier station.

**SWITZERLAND:** SBB has awarded an Alstom-led consortium a €9.25m contract to build the Hürlistein substation including 132 kV 16.7 Hz gas insulated switchgear on the Zürich – Winterthur line by 2015.

**UK:** Parsons Brinkerhoff has been awarded the design engineering contract for the Manchester – Salford first phase of the Manchester – York electrification project.

Indian company Infotech is to design a resignalling project to increase capacity at Whitby, the first time Siemens has outsourced the whole of the design aspects of such a project.

**USA:** Wabtec is to supply positive train control equipment for Sound Transit's 130 km commuter route in Seattle. The \$34m contract covers 16 locomotives and 18 driving cars.

**VIETNAM:** A groundbreaking ceremony was held on November 21 for the construction of six bridges on the Hanoi – Ho Chi Minh City line. The 650bn dong project is being funded by Japan International Co-operation Agency and is due to be completed in 2016.

**Subscribe today**  
[www.railwaygazette.com](http://www.railwaygazette.com)



**Stay ahead. Stay informed.**  
**Subscribe today.**

**First choice for the urban rail professional**

Metro Report International is the quarterly magazine dedicated to the urban transport professional, showcasing best practice in trams, light rail, metros, automated people movers and commuter rail. In print and digital formats, each edition includes in-depth news coverage, technical focus, key projects from around the globe, special features and market trends.

Subscribers to Metro Report International receive these exceptional benefits

- **Issues delivered direct** to your home or office
- **Continuous Service** <sup>†</sup> – you can cancel your subscription whenever you like (minimum six issues)
- **Digital Issue** – free of charge, with access to our digital archive
- **Our Guarantee** – if you're not happy with your subscription, we'll refund the remaining issues to you

**Metro Report**  
INTERNATIONAL

<sup>†</sup>For Terms and Conditions, go to [www.railwaygazette.com/terms](http://www.railwaygazette.com/terms)

# 220 km/h in the Gotthard Base Tunnel

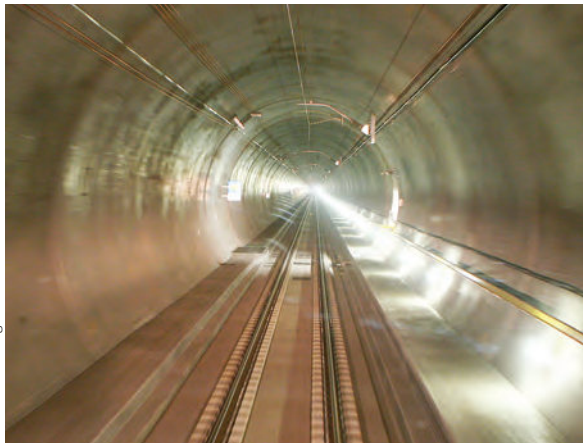

Photos: Lorenz Degen



**Drivers' eye view.** Around 10% of the twin-bore base tunnel is now available for test running (above), using a trainset leased from SBB (right).

**SWITZERLAND:** With the Gotthard Base Tunnel expected to be handed over for regular service in little more than two years, test running is underway on a 13 km section at the southern end of the western bore. Last month *Railway Gazette* was invited by Transtec Gotthard to join a test train between the southern portal at Pollegio in Ticino and the Faido emergency station deep inside the tunnel.

Project manager Alp Transit Gotthard AG selected the Transtec Gotthard group to undertake the railway

systems fit-out in the 57 km base tunnel (RG 7.11 p42). Balfour Beatty Rail and Renaissance Construction (formerly Alpine Bau) are responsible for the track, while Balfour Beatty is working with Kummler+Matter to install the 15 kV 16.7 Hz traction supply. Other 50 Hz power supplies and wiring are being provided by Alpiq Burkhalter Technik, while telecommunications and signalling are being supplied by Alcatel-Lucent Schweiz and Thales respectively.

The testing programme is intended

to confirm that the tunnel and its equipment conform to specification before the completed project is handed over to Swiss Federal Railways in mid-2016. The programme covers all processes, systems and equipment, including the track, catenary, power supply, communications and train control, as well as the various safety systems. This will help reduce the risk of any delay to the planned start of revenue operation in December 2016.

For the test runs, which began in December 2013 and continue until June 2015, AlpTransit has leased from SBB a push-pull inter-city trainset formed of a driving trailer, three passenger coaches, a test car and a pair of Class Re 460 locomotives.

The first runs were limited 40 km/h, but the speed was subsequently raised in steps, first to 80 km/h and then 160 km/h from December 16. The train is currently running at up to 220 km/h. Conventional passenger trains are expected to operate through the tunnel at 200 km/h, which is the usual limit for the Re 460s, but safety regulations require the line to be tested at 10% above the regular speed. Two locomotives are therefore needed to provide sufficient acceleration in order to reach 220 km/h within the 13 km available for testing.

The tunnel is designed for operation at 250 km/h, which will require testing at up to 275 km/h in due course. However, it has not yet been decided what rolling stock would be used for these tests, which would also require a longer distance than the 13 km currently available. Trains are scheduled to begin running through the whole 57 km tunnel in 2015.

Driver Daniel Egger was in charge of our train, accompanied in the cab by Hannes Müller, CEO of Balfour Beatty Rail Switzerland. 'It is great to be part of such an ambitious project', said Müller, reflecting on BBR's role within the Transtec Gotthard group.

The maximum speed of 220 km/h was only maintained for about 1 min during the short run. The ride was very smooth and quiet, thanks to the embedded concrete trackform, in which the rails are supported by boot-pressed concrete blocks rather than transverse sleepers. Conventional catenary has been installed in the Gotthard, although a rigid overhead bar is envisaged for the Ceneri Base Tunnel.

## Record ridership in 'a challenging year'

**SWITZERLAND:** The average number of passengers carried on Swiss Federal Railways passed the million passengers/day mark for the first time in 2013, the operator revealed on March 25. Reporting its annual results for the year, SBB also announced that its freight business had achieved a positive net income for the first time in more than 40 years.

In what it described as 'a challenging year', SBB's consolidated net income fell from SFr422.5m in 2012 to SFr238.2m, with free cash flow after public-sector funding down from SFr905.8m to SFr652.9m. This reflected a SFr332.1m increase in operating expenses and investments totalling SFr3 562.2m, as well as some one-off transactions in 2012.

The average ridership of 1 002 000 passengers/day was up 3.7% on 2012, while total passenger-km were up 1.3% to 17.8 billion. SBB said this was largely because of improved services in French-speaking Switzerland, where it was offering 30% more seats and 14 additional trains, as well as the launch of a 2 trains/h Zürich – Schaffhausen service.

Traffic in the 'self-financing' long-distance passenger business was up 1.4% to 13.1 billion passenger-km, while ridership on the subsidised regional services increased by 1.0% to 4.7 billion passenger-km. Fare increases averaging 5.2% in December 2012 covered 80% of the SFr163m increase in train-path costs, but higher access charges and the expenses from running more services 'drastically' cut the Passenger Division's operating surplus to SFr96.1m from SFr268.9m the year before. Meanwhile, the proportion of passengers

reaching their destinations within 3 min of the advertised time fell from 88.0% to 87.5%.

All 1 018 long-distance coaches are to be fitted with mobile phone signal amplifiers by the end of 2014, and the possibility of equipping the regional fleet is being discussed with network operators 'as a matter of urgency'. By the end of 2015 free wi-fi will be available at the 100 busiest stations.

In the 'highly competitive' freight sector, SBB Cargo's traffic grew 1.5% to 12.3 billion tonne-km. Freight revenues rose by 4.7%, enabling the operator to post a positive net income of SFr14.7m, which was SFr65.9m better than the previous year. However, SBB warns that the market 'remains challenging both nationally and internationally, and competitive pressure from road transport remains heavy'.

SBB's Infrastructure Division reported an overall loss of SFr72.3m in 2013, compared to a profit of SFr37.1m in 2012. Train-km rose by 2.7% to 170.0 million, and in the first few months of the year the volume of maintenance work exceeded forecasts by SFr128.6m. A new diagnostics vehicle was instrumental in pin-pointing new maintenance requirements, as were the results of an inquiry into a broken rail. Work to fit automatic train protection at around 1700 signals has been stepped up following a review into two collisions between regional trains at Granges-près-Marnand and Neuhausen (RG 12.13 p22), and SBB says it is 'currently considering whether the planned introduction of continuous speed monitoring' using ETCS Level 2 'can be expedited'.



# Essential business information that gives you the edge



Print • Digital • Online

The Railway Gazette portfolio of publications provides the most comprehensive source of business information for the global rail industry.

The number one publication for the international rail industry



[www.railwaygazette.com](http://www.railwaygazette.com)

## INTELLIGENCE Main Line

### SWITZERLAND

## Stadler wins high speed train contract

Stadler Rail has beaten off rival bidders Alstom and Talgo to win a SFr980m contract to supply Swiss Federal Railways with 29 articulated trainsets for international services through the Gotthard base tunnel.

Delivery of the 11-car EC250 trainsets with a maximum speed of 249 km/h is due to start in late 2019, three years after the base tunnel opens in December 2016. Designed to operate in Switzerland, Italy and Germany, the trains will be built at Stadler's Bussnang plant with bogies supplied from Winterthur.

Each 200 m long set will include a dining car and accommodation for around 400 passengers. Low-floor entrance doors in the centre of each car will offer easy access for disabled, elderly and luggage-encumbered passengers. Two classes of accommodation will include quiet, family and business zones with power sockets at all seats. There will be separate



male and female and two disabled-accessible toilets.

The trains will displace ETR610 and ICN tilting trainsets on inter-city services via the Gotthard. They will initially operate from Basel and Zürich to Milano, but SBB envisages deploying them later on other international routes as it holds options for up to 92 more trainsets. ■

Announcing the order on May 9, SBB said that Stadler Rail was the clear winner with a definite lead in meeting the bid criteria.

### AZERBAIJAN

## ADDY orders Alstom locos

National railway ADDY has placed a €300m order for 50 Alstom KZ8A twin-section 25 kV AC electric freight locomotives to be delivered in 2016-18. They are to be supplied from Astana in Kazakhstan by the EKZ joint venture of Kazakh national railway KTZ (50%), Transmashholding (25%) and Alstom (25%). Alstom's share of the contract announced on May 12 is worth €150m. Options for the construction of a depot, technical assistance, maintenance and staff training are to be negotiated in the next six months.

EKZ is supplying 200 KZ8A locomotives to KTZ under a contract signed in March 2011. The 1520 mm gauge KZ8A is rated at 8.8 MW, has a maximum speed of 120 km/h and can haul up to 9000 tonnes.

'Azerbaijan is a strategic transit point between Europe and Central Asia', said Thibault Desteract, Senior Vice-President of Alstom Transport Russia & CIS. 'The modern KZ8A freight locomotives will help increasing its carrying capacity in transportation of raw materials and goods.'

In 2006 Azerbaijan railways launched a long-term modernisation programme which envisages a doubling of current traffic volumes by 2017. ■

### NIGERIA

## Coastal line framework

The Federal Ministry of Transport and China Civil Engineering Construction Corp signed a framework agreement to go ahead with the Coastal Railway project on May 5. Detailed negotiations will now take place before the conclusion of a final construction contract, which the China Railway Construction Corp subsidiary estimates will be worth US\$13.1bn.

An agreement for CCECC to plan the railway was signed in 2010. The route would run around 650 km across the country from Calabar in the east to Aba, Port Harcourt, Warri, Benin City and Lagos in the west. The standard gauge alignment totalling 1385 track-km would pass through 10 states, have 22 stations and be designed for speeds of 120 km/h.

CCECC said in the longer term the line could eventually form part of the proposed Ecowas Railway linking Economic Community of West African States countries. ■



CCECC has begun tracklaying in Ethiopia on the new standard-gauge line under construction between Addis Ababa and Djibouti.

### AUSTRALIA

## NSW seeks inter-city fleet

Plans to order around 65 trainsets totalling 520 cars for NSW TrainLink Intercity services between Sydney and the Central Coast, Newcastle, the Blue Mountains and Illawarra were announced by New South Wales Minister for Transport Gladys Berejiklian on May 8. Industry briefings will be held with a view to identifying 'a train already available to the market'. The estimated A\$2.8bn cost of the order would be funded by the state.

'Previously, NSW has developed unique and often costly train fleets from scratch, which has taken as long as seven years from start to delivery', said Berejiklian. 'We are looking at buying off-the-shelf trains with proven technology and then configuring them to meet our customers' needs, meaning we can ensure the best value, best possible service and also have these new trains on the tracks faster. We expect the first train will be in passenger service by 2019 and the new fleet will be progressively rolled out through to 2024.' The current Oscar train fleet would be reallocated to Sydney suburban services. ■

### ASIA

## Caspian link agreement

An agreement to complete the 167 km missing section of the planned north-south corridor along the west of the Caspian Sea was reached by the heads of the national railways of Iran, Azerbaijan and Russia during the 60th meeting of the Council for Rail Transport of CIS States last month.

Russian Railways is to build the Iranian section of the route between Rasht and the border with Azerbaijan near Astara, while Azerbaijan's ADDY will be responsible for construction of the section within its territory.

Construction of a 165 km line linking Rasht to the Iranian network at Qazvin is now nearing completion with opening planned by the end of this year. Once completed, the cross-border route is expected to carry 1.4 million passengers and 5 to 7 million tonnes of freight a year.

★ Iranian Islamic Republic Railways has applied to become an associate member of the Council for Rail Transport of CIS States. ■

## SWITZERLAND

# Golden sleeper

Tracklaying in the 57 km Gotthard base tunnel was completed at 12.00 on October 31, when the concrete was poured for a 'Golden Sleeper' 54 m from the southern portal.

Installation of the railway systems is being undertaken by the Transtec Gotthard consortium, within which Balfour Beatty Rail and Renaissance Construction (formerly Alpine Bau) are responsible for tracklaying. Installation of Sonnevile low-vibration track with 290 km of rail, 380 000 concrete sleeper blocks and 131 000 m<sup>3</sup> of concrete took 39 months, employing 125 workers in shifts around the clock, seven days a week.

Electrification and signalling are due to be commissioned over the next 12 months, ready for the start of full test



running in the autumn of 2015; testing at up to 220 km/h has been underway for some months, using a 13 km section of one bore.

Alptransit Gotthard has set June 2 2016 as its target date for the opening ceremony. It will then hand over the tunnels to Swiss Federal Railways, allowing six months for driver training before the start of commercial operations with the December 2016 timetable change. ■

**Transtec Gotthard Chairman Marco Hirzel said it was 'only thanks to advance planning and co-operation between the 720 people engaged in this work that we can achieve the goal of a timely handover'.**

## NIGERIA

# Coastal Railway contract signed

Nigeria's federal government and China Railway Construction Corp officially signed the US\$11.97bn contract to build the 650 km Nigerian Coastal Railway linking Calabar in the east to Aba, Port Harcourt, Warri, Benin City and Lagos in the west at a ceremony in Abuja on November 19. According to CRCC, the deal is the single largest international contract awarded to a Chinese firm.

CRCC's parent company China Civil Engineering Construction Corp has been developing the project since 2010, and signed a framework agreement on May 5 during a visit by Chinese Premier Li Keqiang

who committed to providing investment and expertise (RG 6.14 p12).

The east-west corridor will augment NRC's existing north-south lines running inland from Lagos and Port Harcourt to Kaduna as well as the Warri – Ajaokuta – Abuja line. The railway is to be built to 'Chinese standards' suitable for maximum speeds of 120 km/h, and requiring 1 385 km of 1 435 mm gauge track. The project will require Chinese exports totalling US\$4bn, including construction machinery, steel products and rolling stock. ●

## ITALY

# FS Group privatisation options

The Ministry of Economics & Finance is to 'consider the various feasible options' for the privatisation of some or all of the Ferrovie dello Stato Italiane Group, Managing Director Michele Mario Elia said on November 5. Speaking on the fringes of the European Rail Summit (p3), Elia said any decision on future restructuring of the group would be taken by the government, currently the sole shareholder. 'In my personal opinion, the priority today is to retain the integrity of the group', Elia explained, 'but this does not preclude possible future options for partial privatisation.'

FS has ongoing plans to maximise the commercial activities of parts of the group, including station and property arm Grandi Stazioni and its power transmission operations. Elia said options would be assessed with a view to implementation from 2016.

Meanwhile, Elia restated FS's commitment to strengthening its operations in countries 'close to Italy'. He saw further opportunities for its Netinera subsidiary to win operating concessions in Germany, and hoped that the Thello joint venture with Transdev could introduce more trains between Italy and France, building on the Marseille – Milano service launching on December 14. Next June's Expo 2015 in Milano would be an opportunity to increase traffic on routes to Switzerland.

In the longer term, Elia said that he was 'hopeful' that the European liberalisation process would permit FS to compete internationally on a reciprocal basis, for example by running ETR1000 high speed trainsets on the French network 'in commercial service, not just for tests'. SNCF already has a foothold in the Italian market through its minority share in high speed open access operator NTV. ■

## NEWS IN BRIEF

**PKP Intercity** closed its VIP zones last month, citing lack of use. The first of the high-standard first class lounges offering inclusive catering and newspapers opened in Warszawa in 2007, with Wrocław and Kraków following.

**India's** Ministry of Railways and **South Korea's** Ministry of Land, Infrastructure & Transport signed a memorandum of understanding for technical co-operation in the rail sector in Seoul on November 17.

A ceremony in Nürnberg on November 5 launched construction of a new €3.5m depot for **DB Netz's** fleet of 850 track maintenance vehicles.

Indian Railways' first station **wi-fi** installation has been inaugurated at Bangalore City. The RailWire wi-fi programme covering all category A and A1 stations is being undertaken by the Ministry of Railways' RailTel Corp business. Access is free for 30 min, and passengers can buy further time using scratch cards or online.

The Chinese government has agreed in principle to provide a soft loan to **Thailand** for construction of a line linking Bangkok with Nong Khai.

The 4.5 km Mei Lai Road – Hoi Ting Road twin tunnels on Hong Kong's **Express Rail Link** were broken through on October 24.

The Alstom-led **Gibela** joint-venture is to start construction in mid-2015 on a 600 000 m<sup>2</sup> factory in Dunnottar to produce electric multiple-units for Passenger Rail Authority of South Africa (RG 7.14 p40).

The **UK** government has agreed to cover the £105m cost of extending the ongoing Great Western Main Line electrification programme to include the Cardiff – Swansea route. It is also to contribute £125m towards the costs of the Valley Lines electrification scheme.

Chinese President Xi Jinping has pledged US\$40bn to set up a fund for infrastructure projects linking **Asian** markets.

**GySEV** is to electrify the Hegyeshalom – Csorna – Porpác route in western Hungary at a cost of HF12bn.

The introduction of additional trains on four routes from the December timetable change means that all stations served by Dutch national passenger operator **NS** will now have at least one train in each direction every 30 min.

PKP Cargo subsidiary **Cargosped** has launched an intermodal service from the ports of Gdańsk and Gdynia to the Franowo terminal in Poznań. It runs four times a week, and is expected to increase to daily from early 2015.

# Gotthard Base Tunnel completes LVT installation

The successful completion of tracklaying through the world's longest railway tunnel reflects the continuous development of low-vibration ballastless trackforms in Switzerland over half a century, with further applications now in prospect.

October 31 saw the formal completion of tracklaying in the Gotthard Base Tunnel, with the installation of the final section of slab track, ahead of the timetable agreed in 2009. Thanks to the use of automated tracklaying

Both high-attenuation and standard LVT trackforms are used in the Gotthard Base Tunnel.

processes, the construction timescale has been significantly shortened, which in turn has allowed the start of commissioning to be brought forward by a year, ready for commercial operations to begin in December 2016.

As well as being the world's longest railway tunnel, the Gotthard Base Tunnel is the longest single application of ballastless slab track in Switzerland to date. And as such it has benefited from a continuous programme of research and development stretching back more than half a century.

Swiss Federal Railways began research into the use of slab track in the early 1960s, with the aim of developing a durable and low-maintenance trackform for its long tunnels through the Alps. Like Japan, where the J-Slab system was developed around the same period, Switzerland has many years of experience in ballastless track technology. Today, this is becoming increasingly important as SBB looks to maximise the availability of its infrastructure in order to cope with increasing volumes of traffic.

## Early thinking

Given the importance of north-south trans-Alpine transit traffic, an expert committee was established in November 1963 to examine different track technologies and the specific requirements that should be applied in Switzerland. Very early on it became clear that non-ballasted track was the best option for use in the long Alpine tunnels. A conceptual design was developed in 1964 based on feedback from high speed track experience in Japan, and the philosophy expounded by Albert Einstein: 'make everything as simple as possible, but not simpler'. That concept has proven its worth right up to the present day.

Specific requirements were that the track components should be well proven in service, with established maintenance procedures, that provision could be made to ensure the required elasticity and vertical track deflection, and that the interchangeability of all track

## DIPL-ING PETER LABORENZ

Head of Slab Track Division  
Vigier Rail AG  
President, Sonneville AG  
[peter.laborenz@vigier-rail.ch](mailto:peter.laborenz@vigier-rail.ch)

## DR-ING WALTER STAHL

Head of Projects & Academic Councillor  
Institute of Road, Railway & Airfield Construction  
Technische Universität München  
[walter.stahl@vwv.bv.tum.de](mailto:walter.stahl@vwv.bv.tum.de)

## DIPL-ING THOMAS SILBERMANN

Construction Manager  
ARGE Fahrbahn Transtec Gotthard  
Renaissance Construction AG  
[thomas.silbermann@afttg.ch](mailto:thomas.silbermann@afttg.ch)

components could be guaranteed. The construction method needed to allow for the track position to be checked and corrected before it was finally embedded in the base slab.

Around the same time, SNCF and its then Trackwork Development Engineer, Roger Sonneville, were developing a trackform using twin-block sleepers connected by a metal angle bar, and this was adopted in Switzerland. The two concrete sleeper blocks are encased in rubber boots to isolate them from the in-situ cast concrete slab, and a flexible pad is placed inside each boot, below the blocks, to provide the necessary degree of elasticity.

## Trial installations

SBB found its first opportunity to test the concept with a short section of track in the Bötzing tunnel laid in 1966<sup>1</sup>. This was followed by a large-scale trial in the 4.8 km twin-track Heitersberg tunnel which opened in 1975<sup>2,3</sup>. Detailed measurements could then be taken with trains passing at speeds of up to 200 km/h, allowing the track component specifications to be optimised.

The good results, both in technical terms and in the detailed cost comparisons with traditional ballasted track, led to further newly-built tunnels being equipped with slab track, including the Zürich airport tunnels in 1979, the Zürich S-Bahn station at Museumstrasse in 1990 and the 5 km Zürichberg which opened the same year.

The Heitersberg tunnel pilot project was effectively concluded in 2014,



# Low-vibration TRACK



The LVT support blocks on one track in the Heitersberg tunnel (right) were renewed in 2014 using a series of short possessions.

when the twin-block sleepers on one of the two tracks were replaced in a series of overnight possessions. Working in 100 m sections, the old twin-block sleepers, including the elastic components, were replaced by new B12 blocks with the W14 rail fastenings specially developed for the relaying project. At the same time, the SBB IV rail profile was replaced by SBB VI (UIC60)<sup>7</sup>.

After the sleeper blocks had been changed on each track length, the line was put back into operation at the normal operating speed of 140 km/h. No subsequent track geometry corrections or concreting work had to be carried out.

The so-called 'Bötzberg system' has been gradually refined over time. The first step was the removal of the cross-ties from the twin-block sleepers in the track at Zürich airport, with the objective of improving the protection against vibrations; this modified version was also adopted for the Zürich S-Bahn projects<sup>4</sup>.

In the meantime, Sonnevile International had been further developing the low-vibration track system with individual blocks. This had been adopted for the Channel Tunnel project, and trials at the beginning of the 1990s proved that a substantial improvement could be achieved in terms of gauge widening and lateral track geometry stability by embedding the single support points up to 50% deeper in the track slab. In addition, the electrical resistance was improved by removal of the metal cross-ties, with major advantages for the signalling. In platform areas, slab track without cross-ties was much easier to clean, and it allowed good access for inspection by maintenance staff.

Having installed Sonnevile LVT on an 800 m section of the Grauholz Tunnel, which was commissioned in 1995<sup>5</sup>, SBB subsequently decided to use it throughout the 5 km Zimmerberg tunnel. Forming part of the NEAT trans-Alpine corridor, this tunnel was designed for a line speed of 200 km/h. The track design is noteworthy, because both

the infill concrete in which the blocks are embedded and the tunnel invert itself have no structural reinforcement<sup>6</sup>.

Four years after the Zimmerberg tunnel opened in 2003, BLS inaugurated the 35 km Lötschberg Base Tunnel, which is another integral part of

Switzerland's north-south transit corridors. Following on from the SBB developments, BLS also decided to specify LVT for the 53 km of track, which like the Gotthard Base Tunnel has been designed for a line speed of 250 km/h.

In this case, the LVT trackform was equipped with rubber boots that allow improved vertical deflection of the individual blocks, as well as under-block pads made of polyurethane. Together, these changes contributed to an improvement in the dynamic behaviour of the system.

## Durability testing

Before selecting the final trackform for the Gotthard Base Tunnel, SBB required extensive testing of the various components, to ensure that they could withstand the predicted stresses in the tunnel environment, with temperatures of around 40°C and 70% humidity. The

Right: Fig 1. Determination of system rigidity moduli on a test specimen inclined at 22°.



Far right: Fig 2. Instrumented track cross-section, showing the amplifier, data recorder and remote transmitter in the background.

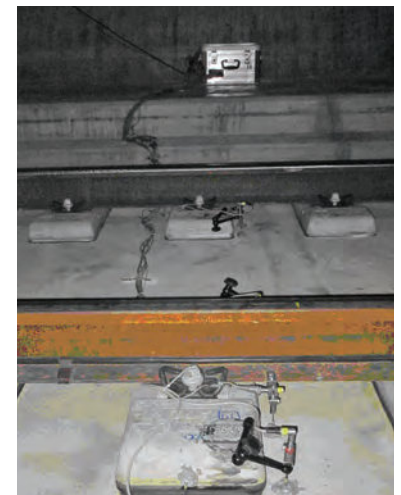

Below: Fig 3. Sequence of rail deflections recorded at 220 km/h during tests in the Gotthard Base Tunnel.

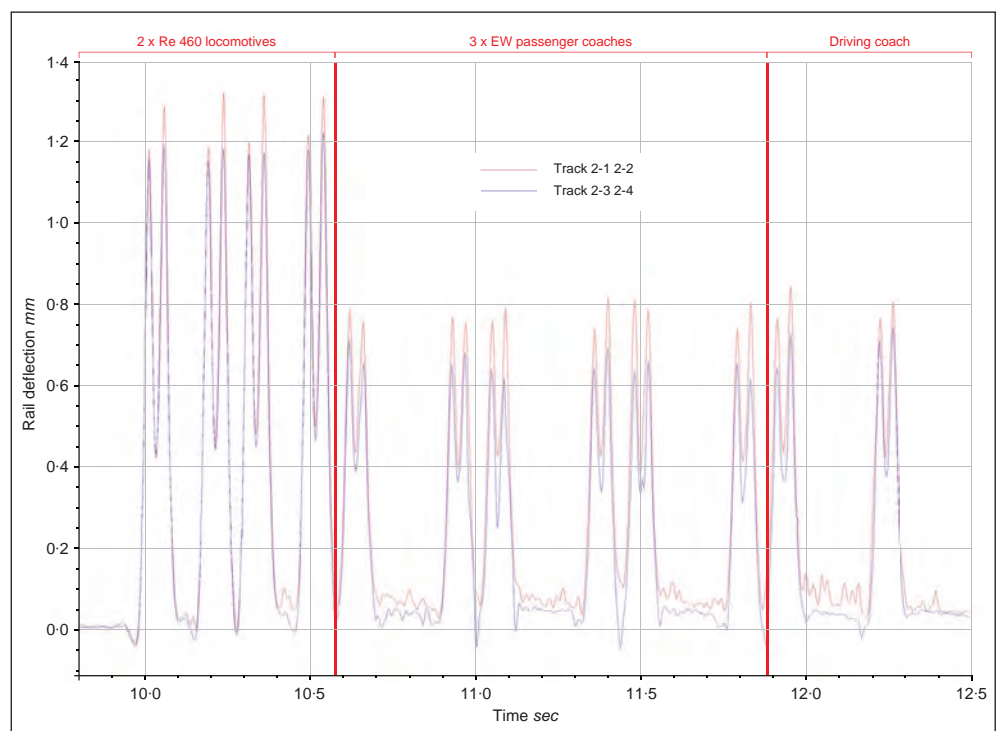

## TRACK Low-vibration



main requirements were durability and a long service life, given the anticipated loading of 0.5 million tonnes per day with a maximum axleload of 25 tonnes.

The sleeper blocks for the GBT project were manufactured by European LVT licensee Vigier Rail Ltd using a new production process based on the use of self-compacting concrete. An increased level of automation offered a consistently high quality, along with guaranteed traceability of all the components and materials used. It was also possible to increase the geometric accuracy, thanks to the use of high-precision moulds. As each support can be 'cloned', a one-for-one replacement becomes more feasible, which may prove necessary to rectify any damage from a derailment or objects falling onto the track, for example.

An essential part of the test programme was the cyclic load tests, which were carried out at the Institute of Road, Railway & Airfield Construction in München. Sample track components were subjected to more than 10 million load cycles, under conditions which simulated the ambient tunnel temperature.

The static and dynamic (1 to 15 Hz) system modulus of rigidity was first determined, using 'new' specimens installed at inclinations of 0° and 22°. The dynamic fatigue test was then carried out to 10 million cycles, with a load application angle of 22° and a temperature of 40°C to simulate the worst-case conditions. The system rigidity moduli were determined again, so that the 'before' and 'after' values could be compared.

The test specimens exhibited support point spring rates between 28.4 kN/mm (vertical load, static) and 50.0 kN/mm (-22° load, dynamic). As regards the dynamic demands, both specimens demonstrated a stiffening of approximately 30%, which did not increase much further at a loading frequency greater than 5 Hz. This met the requirements of

**The LVT HA trackform was used for the Zürich Durchmesserlinie to minimise ground vibration in an urban area.**

project promoter Alptransit Gotthard, which specified a static rigidity of greater than 25.0 kN/mm with a horizontal inclination and a dynamic rigidity of less than 55.0 kN/mm with an inclined installation.

During the dynamic fatigue test, both specimens were tested simultaneously. Once the required temperature of 40°C between the block pad and the bottom of the concrete block had been reached, 10 million load cycles were applied with a vertical load component impact of 60 kN per support. One criterion in the tender specifications was that the amplitude or the change in displacement amplitude should be less than 20% between 100 and 10 million load cycles. The other was that the support points should not wear through, and the boot must not show wear of more than 50% of the wall thickness at any point. Examination of the specimens showed that both criteria had been met. A visual examination of the track system components after 10 million load cycles revealed only slight signs of wear, which it was concluded were due to the effect of initial adjustments or possible restraints.

With construction well advanced, the contractors also undertook practical dynamic deflection measurements in February and March 2014, using the 13 km long Faido – Bodio test section in the western bore of the tunnel. On February 20-21, the deflection was measured under a Class Re420 electric locomotive running at speeds of 10, 80 and 120 km/h. On March 11-13 tests were undertaken using a pair of Class Re460 locomotives and four coaches, running at 160, 180, 200 and 220 km/h. These last runs were also being used to test the traction current supply at the same time.

The measurements were taken close to cross-passage 150, which lies about half-way along the test section. The same instrumentation arrangement was used as for the laboratory tests, with

inductive displacement transducers on the left and right rails at three cross-sections (Fig 2). Measurements were taken automatically during both sets of trials and also monitored and recorded at a base in the village of Biasca via a network link.

Fig 3 shows the measured rail deflections from a test at 220 km/h at measurement cross-section 2. A 100 Hz low-pass filter was used to analyse the signals. Fig 4 shows the average value of the maximum rail deflection under the locomotive axles for the trial runs at the various speed levels.

In summary, the rail deflection at the measured support points remained virtually the same, at approximately 1.3 mm for both quasi-static and dynamic loading. The deeper deflections measured at speeds of 80 km/h and 120 km/h can be attributed to the dynamic influences of the loading vehicle, which have a greater effect on the deflection curve than the stiffening of the elastic material. A stiffening of 1:3 which was determined during the laboratory trials in 2010 was not significantly exceeded during the practical testing.

Given that in the LVT track structure it is mainly the deformation of the elastic block pad that contributes to rail deflection and support rigidity, the dynamic behaviour of the system as a whole corresponds to the behaviour of the block pads<sup>8</sup>.

### Installation methodology

The tracklaying process for the Gotthard Base Tunnel was described in detail in RG 7.11 p44. Awarded the tracklaying contract in 2008, the ARGE Fahrbahn Transtec Gotthard consortium of Balfour Beatty Rail and Renaissance Construction brought together a team of trackwork specialists with international experience. The consortium developed an installation methodology that guaranteed very high

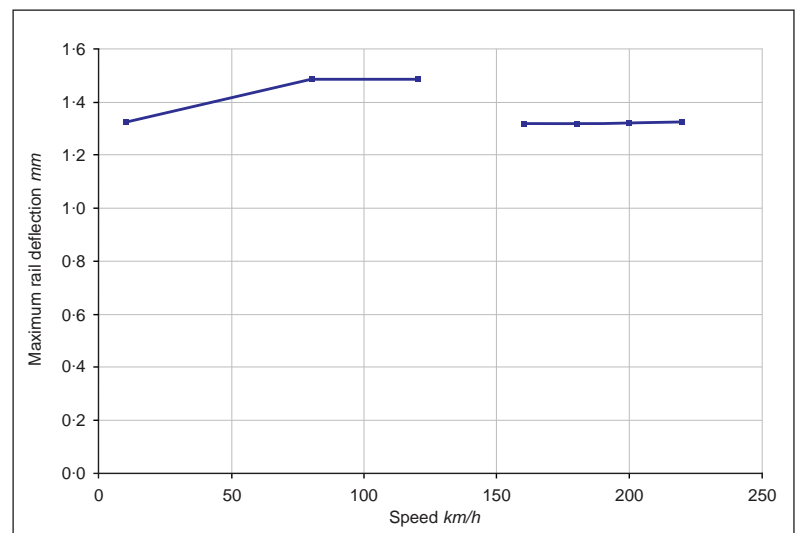

**Fig 4. Average value of maximum rail deflection under locomotive axles at different speeds.**

# Low-vibration TRACK



A ceremony to mark completion of tracklaying in the Gotthard Base Tunnel was held on October 31.

quality construction while making extensive use of mechanisation. These concepts were verified over a two-year period before the start of installation, which also provided time for detailed planning, and to finalise the design of the equipment.

The trackbase concrete was delivered using a 500 m long in-situ mix concrete train. A variety of concrete mixes were tested extensively in order to optimise the characteristics required for both placing and early strength. The final choice was confirmed by the laying of a test section at the worksite near the southern portal, requiring approximately 1 000 m<sup>3</sup> of concrete.

When the concrete transporter began its final run on October 31, for the last of 25 156 trips, carrying 4.8 m<sup>3</sup> of high quality concrete to the installation point, the tracklaying was completed on time, almost to the minute, in a performance equivalent to Swiss 'watch-making' accuracy. No less than 114 km of slab track, including eight turnouts, had been installed as scheduled, without a single unplanned interruption of more than two days.

More than 380 000 LVT supports and around 13 800 tonnes of rail were installed in detailed half-day stages, with the automated track assembly machines completing 2 160 m of slab track every 20 days, operated by a team of 85 specialist workers over three shifts. With a proven average deviation of only 0.3 mm, the accuracy of the track installation is equivalent to a match split down the middle, probably the highest standard ever achieved on a major railway project.

### Development continues

But the story does not end here. SBB is now looking to install slab track wherever there is a rigid track substructure, including bridges and viaducts as well as tunnels. The 394 m

Kohlendreieck bridge and the 1 156 m long Letzigraben viaduct which form part of the Zürich Durchmesserlinie project will be the first long bridges in Switzerland to be laid with LVT slab track when they open later this year.

At the same time, development work is continuing for slab track applications in urban applications, reflecting the requirement to minimise ground-borne vibration. This should assist in enhancing the acceptance of rail projects in Swiss cities. SBB has already taken an important step by adopting the LVT HA variant for the Durchmesserlinie and a short section of the Gotthard Base Tunnel. This trackform provides improved attenuation of ground-borne vibrations (RG 8.12 p44).

Another workstream is investigating the scope for laying slab track in short possessions, to replace existing ballasted track in tunnels and on bridges while minimising the interruption of services. In particular, Switzerland has a large number of tunnels where the high density of traffic only offers a small window for maintenance work. The use

of a low-maintenance trackform would offer significant benefits over time, providing that it is possible to install it in the first place. This is likely to be an increasingly important issue, which SBB will need to keep under scrutiny over the next few years.

Continuous improvement based on experience with tracklaying is helping to boost the speed and efficiency of installation, and this should make the use of slab track more attractive to other railways. While the life-cycle costs of LVT are currently around 8% lower than those of standard ballasted track, the initial capital cost is still higher.

However, as past experience has shown, development of both the slab track system and the installation techniques requires close co-operation between the suppliers and the railway companies in order to achieve the best possible results. This should ensure increased use of LVT, not just in Switzerland but around the world. ■

### References

1. Ensner, S. Versuche mit bettungslosem Geleise. *ETR* 1970, Heft 1.
2. Hofmann, P. Renouvellement de voie sur le tronçon d'essai sans ballast dans le tunnel du Boetzberg des chemins de fer fédéraux suisses, à la suite d'un déraillement. *Revue Générale des Chemins de Fer*, October 1980.
3. Hofmann, P. Schotterloser Oberbau im Heitersberg-tunnel. *SBB-Nachrichtenblatt* 1974 Heft 11.
4. Hofmann, P. Oberbau-Konstruktionen bei den Schweizerischen Bundesbahnen. *ETR* 1988.
5. Rutishauser G. European Slab Track Symposium 2005.
6. Hofmann, H. Feste Fahrbahn bei den SBB *Eisenbahn Ingenieur* Vol 49 No 4, 1998.
7. SBB: Der Zimmerberg-Basistunnel. Basler & Hofmann Ingenieure und Planer AG, Zürich, 2004.
8. Sanierung der Fahrbahn im Heitersberg Tunnel. <http://www.youtube.com/watch?v=EljqUN8QV3g>
9. Forschungsbericht 2637. Systemprüfung am FF-System LVT 2 – ATG. Creabeton Matériaux, 2010.

SBB is intending to use slab track on new bridges and viaducts, including those for the Durchmesserlinie opening this year.



Subscribe today and **save 20%\***

[www.railwaygazette.com/subs112](http://www.railwaygazette.com/subs112)



# Stay ahead. Stay informed. Subscribe today.

**The number one publication for the international rail industry**

Railway Gazette International is the monthly news magazine serving the global rail market. With more than 170 years of editorial excellence, every issue provides readers with the latest news, features, analysis and technical information from the heart of the rail industry.

Subscribers  
to Railway Gazette  
International receive  
these exceptional benefits

- **Issues delivered direct** to your home or office
- **Continuous Service** † – you can cancel your subscription whenever you like (minimum six issues)
- **Discount** – subscribe today and save 20% off the normal rate\*
- **Digital Issue** – free of charge, with access to our digital archive
- **Our Guarantee** – if you're not happy with your subscription, we'll refund the remaining issues to you

# Railway Gazette

INTERNATIONAL





between the Belgian port and Le Havre. From September, B Logistics hopes to introduce a further route to serve destinations in Sweden, operated in partnership with Green Cargo.

Giving customers a realistic, consistent and deliverable timetable is essential for Green Xpress to grow volumes to a sustainable level, B Logistics believes. As a result, it is investing heavily in advanced back-office systems and decision support tools. On the operational side these include online diagnostic support to accelerate pre-departure checks, and sleep sensors to monitor driver alertness. Customers will be offered an on-line portal for fast quotes, booking and payment, while the Cargoweb online portal and smartphone app will give them rapid access to real-time tracking and arrival time information for their shipment. ■

#### SWITZERLAND

## Tunnel preparations

With just 12 months to go until the Gotthard Base Tunnel is due to be handed over by project promoter Alp-Transit Gotthard AG, Swiss Federal Railways announced on April 30 a programme to modify rolling stock and undertake training for around 3900 staff in time for the start of operations with the timetable change on December 11 2016.

The rolling stock changes are needed to improve fire safety and to install ETCS Level 2 cab signalling. According to SBB, the Alstom-built ETR 610 Pendolino trainsets used for international services over the Gotthard corridor were equipped by the manufacturer before delivery. However, the older trains do not meet the technical specifications for operation through the world's longest rail tunnel, notably

regarding fire protection, the ability to keep running in the event of a fire and pressure sealing. To bring them up to the required standards, fire alarm systems and sensors will be installed, along with fire-resistant doors between the vehicles and foam extinguishers. At the same time, SBB is to install new air-conditioning equipment to improve the level of comfort for both passengers and train crew.

Retrofitting will be required for 18 ICN tilting trainsets, 13 Class Re 460 electric locomotives and 119 inter-city coaches used by the passenger business, plus 179 main line and 15 shunting locomotives for SBB Cargo. The work will be undertaken at SBB's workshops in Bellinzona, Biel, Yverdon-les-Bains and Olten, and is due to be completed by mid-2016.

Over the next 18 months SBB must also complete infrastructure modifications at locations between Brunnen and Castione in conjunction with the introduction of ETCS Level 2, and commission two electronic interlockings at Altdorf and Pollegio. New maintenance and intervention centres are being developed at Erstfeld and Biasca, where around 300 staff will be based to undertake maintenance and troubleshooting in the base tunnel.

SBB sees the opening of the Gotthard Base Tunnel as 'the most important milestone' in the upgrading of the north-south transalpine corridor, but says the full benefits will not be realised until the Ceneri Base Tunnel is completed in 2019, paving the way for the carriage of 4 m high loads from 2020. Between now and then, it says, another 25 projects must be implemented to upgrade the access routes from Basel in the north and Chiasso in the south.

★ On May 7 intermodal operators' association UIRR warned that upgrading of the Lötschberg and Gotthard corridors could have 'an undesirable impact' on international transit traffic unless

**Ready to go.**  
B Logistics' Green Xpress network already connects Belgium with destinations in France, Germany, Switzerland and Slovakia.

proposed changes to the commercial conditions were revised. According to a study commissioned from TransCare, 'the enhanced operating efficiency' offered by faster speeds and lower energy consumption 'will be more than offset' by the phasing out of financial support for intermodal traffic and a revised track access charging regime.

Warning that these 'alarming' findings could see traffic diverting eastwards to the Brenner route, UIRR called on Swiss decision-makers 'to implement the necessary adjustments to make the new high-performance rail infrastructure commercially competitive'. Director-General Ralf-Charley Schultze said UIRR had been calling for the upgrading of strategic European rail infrastructure to facilitate modal shift to more environmentally-friendly transport, but 'this can only work if the new infrastructure is available under competitive commercial conditions'. ■

#### NETHERLANDS

## Limburg lost

Meeting on April 29, Limburg Provincial Council decided to cancel the 15-year concession under which NS and its Qbuzz subsidiary were to operate regional passenger services in the Limburg region in 2016-31 through a new business unit, Abellio Limburg.

The contract had been awarded on February 10 following an international competition (RG 3.15 p11), but on March 28 NS admitted that it had discovered 'serious irregularities' in its bid process. Following an internal compliance audit, the national passenger operator brought in lawyers De Brauw Blackstone Westbroek to undertake an independent review.

According to NS, the Qbuzz bid team had received 'unauthorised confidential information' from a former employee of incumbent operator Veolia Transport Limburg, who had been hired through an intermediary despite being subject to a non-competition clause. However, it had not been established whether this had a material impact on the outcome of the tender.

'Shocked' by the results of the investigation, NS apologised to the province. Two directors of Qbuzz and Abellio Netherlands were suspended. The former Qbuzz general manager, who had been acting as a consultant since retiring, had his contract terminated, as did the Veolia employee, who had been due to take up a full-time post on May 1. NS said it was considering whether to take disciplinary action against other employees.

# 207 locos

TO BE RETROFITTED BY SBB WITH ETCS LEVEL 2 FOR OPERATION THROUGH THE GOTTHARD BASE TUNNEL

## ALPINE CORRIDORS Gotthard

# Longest tunnel will transform transalpine traffic flows



Swiss Federal Railways expects passenger traffic on the Gotthard corridor to double by 2025 thanks to opening of the Gotthard and Ceneri base tunnels. Zürich – Milano timings will be cut to 3 h, reports [Murray Hughes](#).

Opening of the Gotthard Base Tunnel in December 2016 and of the Ceneri Base Tunnel four years later will pave the way for fundamental changes in the pattern of inter-city services on Switzerland's main north-south rail corridor. Reflecting SBB's long-standing

Due to enter service in December 2019, the EC250 'Giruno' trainsets will link Zürich and Milano via the Gotthard Base Tunnel.

intention to integrate its inter-city network more effectively with high speed services in Italy and Germany, the changes are an essential element in a strategy to capture a greater share of international passenger traffic on this important route. As part of that strategy, SBB is spending more than SFr1bn on new rolling stock for the Gotthard corridor.

The two bores of the 57 km Gotthard Base Tunnel were holed through on October 15 2010 and March 23 2011. It took 11 years to complete the tunnelling work — if access shafts and cross-passages are added to the main bores, the total length excavated amounted to 152 km. The last four years have been spent fitting out the tunnels with ventilation and other equipment, tracklaying and installing overhead

wires. Test running commenced between the southern portal at Bodio and the 'multi-function station' at Faido in December 2013, with trains running over the 13 km section at up to 220 km/h. Tests continued until June 2014, with 650 trips made on 78 test days.

### Final testing phase

By the end of May 2015 around 97% of railway equipment was in place. With the whole tunnel completely fitted out, the final phase of testing and commissioning is due to start in October 2015 and run until May 2016. Trains will run round the clock to carry out hundreds of different tests — earlier this year AlpTransit Gotthard AG was recruiting staff for this vital task.

The final phase of trials, expected to involve more than 3000 test runs, will lead up to the formal handover, now firmly set for June 1 2016, when AlpTransit Gotthard AG will bequeath the tunnel to SBB. A huge celebration is planned for the weekend of June 4-5 2016, after which the operator will have six months to train and familiarise its staff with the world's longest rail tunnel before it opens for public services on December 11 2016 — although SBB hints that some commercial services may be routed via the base tunnel on a trial basis starting in mid-2016.

The timetable provides for passenger trains to traverse the bores at 200 km/h, giving a transit time of 17 min, with freight taking twice as long as it will travel at 100 km/h. Should it be necessary to make up time, passenger services will, in theory at least, be able to run at up to 249 km/h.

### Faster with tilt?

SBB has been anxious to accelerate passenger services on its prime north-south route for some time, but its attempt in the mid-1990s to use ETR470 tilting trains on this famously sinuous route through the mountains was not crowned with success. Shared between SBB and Trenitalia and initially owned by the Cisalpino joint venture, the ETR470 fleet proved to be trouble-prone, partly because of maintenance problems in Italy. This prompted a

SBB and Stadler unveiled details of the EC250 interior design in a full-size mock-up in July. The mock-up includes first and second class seating and a section of the dining car.



# Gotthard ALPINE CORRIDORS

decision to withdraw the SBB-owned sets by mid-2015. In a bid to attain better reliability, SBB nevertheless judged it worthwhile to spend around SFr10m in 2012 on modifications to improve the fleet's performance. Trenitalia's ETR470 sets were also modified, leading to a more stable timetable.

The ETR470 sets will be replaced by a fleet of ETR610 trainsets, which were built in the same factory as their predecessors in Savigliano, Italy. An initial batch of seven of this latest generation of tilting trains entered service on the Genève – Milano route via the Simplon tunnel in July 2009, around two years later than planned because of delays during manufacture. The trains were later also deployed on the route from Basel to Milano via the Lötschberg route, using the 34.6 km base tunnel

which opened in December 2007.

SBB ordered a second batch of ETR610 units from Alstom Transport in August 2012, and the first of these entered service at the end of 2014. The fleet exhibits minor differences, including an interior in which all seating is aligned with the windows. In January 2015 SBB placed a further order for four more sets. To these can be added seven ETR610 sets owned by Trenitalia which will be modified for use through the Gotthard Base Tunnel, giving a total fleet of 26. This combined fleet will be used for all international passenger services via the Gotthard Base Tunnel when it opens.

### Domestic service

SBB's domestic inter-city trains through the Gotthard base tunnel will be operated by a mix of 18 ICN



The final phase of test running is due to start in October and end in May 2016 before handover from the contractor to SBB one month later.

tilting EMUs plus 13 Re460 locomotives matched with a fleet of 119 MkIV and EuroCity coaches. Work is currently in hand to modify these vehicles for use through the base tunnel. This entails fitting the latest version of Level 2 ETCS (Baseline 2.3.0d), installing fire and smoke detection systems, fitting fire-resistant doors at the car ends and new air-conditioning equipment. Other work will include adaptations to cope with the high temperatures and humidity likely to be encountered in the base tunnel. Together with modifications to 179 main line freight locomotives and 15 shunters, this work is costing SFr15m and should be complete by mid-2016.

### Giruno trains ordered

Deployment of the ETR610 fleets is only a temporary measure as an entirely new build of trains is destined to operate the principal inter-city services from Zürich and Basel to Milano.

From the end of 2019 SBB will put into service the first of its so-called Giruno fleet on the Gotthard route; the name is derived from the Romansch word for a buzzard. Tenders for 29 trains were called in April 2012, and the order was placed with Stadler Rail on May 9 2014. The SFr980m contract was signed at the end of October 2014, but not before legal challenges were mounted by rival bidders Alstom Transport and Patentes Talgo. There were suggestions that it would be politically unacceptable to award the contract to a company outside Switzerland, but SBB said in its defence that Stadler Rail had a 'clear lead' over its competitors. The deal is potentially lucrative as there are options for another 92 trainsets should SBB decide to expand its international operations.

The Giruno, designated EC250 by the supplier, is an 11-car non-tilting articulated design (Fig 1). Equipped to operate in multiple under three and potentially four different power supplies, the single-deck trains (Table I) will be authorised to run in Germany, Italy and Austria as well as on domestic routes. Testing of an initial train is expected to start in March 2017.

When the Giruno fleet starts



# ALPINE CORRIDORS Gotthard

Table I. Main details of Giruno inter-city trainsets for Swiss Federal Railways

Gauge mm	1435
Overall length m	202
Width mm	2900
Height mm	4255
Axle arrangement	2'Bo'Bo'2'2'2' 2'Bo'Bo'2'2'2'
Bogie wheelbase (powered) mm	2750
Bogie wheelbase (unpowered) mm	2700
Wheel diameter, new mm	920
Power supplies	15 kV 16.7 Hz 25 kV 50 Hz 3 kV DC
Entrance door width mm	900
Floor height at low-level door mm	940
Floor height at high-level door mm	1200
Weight in working order tonnes	388.3
Maximum speed km/h	250
Maximum power output at wheel kW	6000
Starting tractive effort kN	300
Second class seats	286+2 wheelchair spaces
First class seats	117+2 wheelchair spaces
Restaurant car seats	17



to contract maintenance of the Giruno trains to the supplier or another bidder, and this was requested as an option during the bidding process.

### Phased timetable improvements

Although opening of the Gotthard base tunnel will usher in faster services, the full benefits will not be felt until around 2020 when the Giruno trains start to enter service and the Ceneri base tunnel opens. By that time the extensive works on the approach routes — partly to allow freight trains to carry 4 m high lorries — will be completed. Around 25 major worksites are envisaged. In the

intervening period SBB will operate an interim timetable that will give passengers a steady flow of improvements as different phases of work are finished.

The process began in June 2014 when SBB and Trenitalia introduced a revised Zürich – Milano service with longer turn-rounds at the termini and more recovery time built into the schedules. Departure times in Milano were adjusted to offer better connections and to give more satisfactory paths on the main line to Chiasso.

Opening of the base tunnel in December 2016 will see the Zürich – Milano timing cut to 3 h 30 min, with Lugano reached in 2 h 30 min.

commercial operations, services will be integrated with the national regular-interval timetable; SBB says it is working with Trenitalia on the timetable concept. The new trains will displace the ETR610 sets, which SBB will switch to routes via the Simplon tunnel, where their tilting ability can be used to good effect.

SBB has been considering whether

**Above right:** SBB is modifying part of its inter-city fleet in its Olten workshops for use through the Gotthard Base Tunnel. Work includes fitting fire and smoke detection systems and installation of fire-resistant doors.

## MECHANISATION

# Coping with the maintenance challenge

The exceptional length of the Gotthard base tunnel means that special arrangements had to be planned for maintenance from the outset. SBB points out that the tunnel is around the same length as the main line from Zürich to Olten and has come up with a concept for scheduled maintenance tasks and a separate arrangement for unplanned work. Every year up to 37 000 person-hours will be needed for maintenance, with over 60% of these allocated for electrical and telecommunications equipment.

One bore will normally be closed for maintenance for 8 h on Saturday and Sunday nights and for 6 h on Monday nights. In normal circumstances, a variety of maintenance activities will be scheduled to take place simultaneously — this will be dealt with by dedicated maintenance trains conveying all materials and staff needed for the different tasks. SBB envisages that these trains will enter the tunnel from both the north portal at Erstfeld and the south portal at Biasca at specified times, halting at several locations to detrain staff and unload materials or detach vehicles. Supplied from dedicated maintenance centres in Erstfeld and Biasca, they will serve up to 11 worksites at a time.

For short-term repairs or other work it may not be possible to wait until the next scheduled maintenance window. Four so-called 'joker intervals' a week have been built into the timetable for each single-track segment of the tunnel. In each case one-third of the tunnel will

be closed for 4 h, allowing services to continue with minimal interruption thanks to crossovers at the multi-function stations at Sedrun and Faido.

A fleet of 31 dedicated dual-mode maintenance vehicles for the Gotthard and Ceneri base tunnels was ordered in September 2013 from Harsco Rail in Ratingen, Germany. Worth SFr93.7m, the contract provided for delivery between January 2015 and April 2016. Various components are being supplied by Swiss firms Ferriere Cattaneo, Nencki, Selectron and APS electronic.

The basic four-axle vehicle has a 550 kW diesel engine and four 280 kW traction motors, giving a travelling speed of up to 100 km/h. On board are a workshop, tool store and a crew area with kitchen, toilet and emergency equipment. At the outer end is the driving cab, while the inner end is occupied by a crane and loading area.

These vehicles will be matched with four-axle carrier wagons that can be loaded with a variety of modules: crew cabins, work platforms, cranes, overhead wire equipment and so on.

Given the likelihood of temperatures as high as 35°C in sections of the running tunnels, special precautions will be

taken to ensure the safety and wellbeing of maintenance staff. As part of the recruitment process, personnel who work in the tunnels will be given medical and psychological tests to determine their suitability for working in the tunnel environment.

In terms of the physical wellbeing of staff, good ventilation will be critical. Air quality will be assured thanks to ventilation plants at Faido and Sedrun which are designed to extract polluted air and supply fresh air throughout the tunnel. In addition, mobile doors can be erected at two specific locations in each bore to ensure that clean air is supplied to a section of the tunnel where maintenance work is in progress — the doors achieve seals that are 95% effective. The personnel modules on each maintenance train will be fully air-conditioned. ■



The dual-mode maintenance vehicles for the Gotthard Base Tunnel are being supplied by Harsco Rail.

# Gotthard ALPINE CORRIDORS

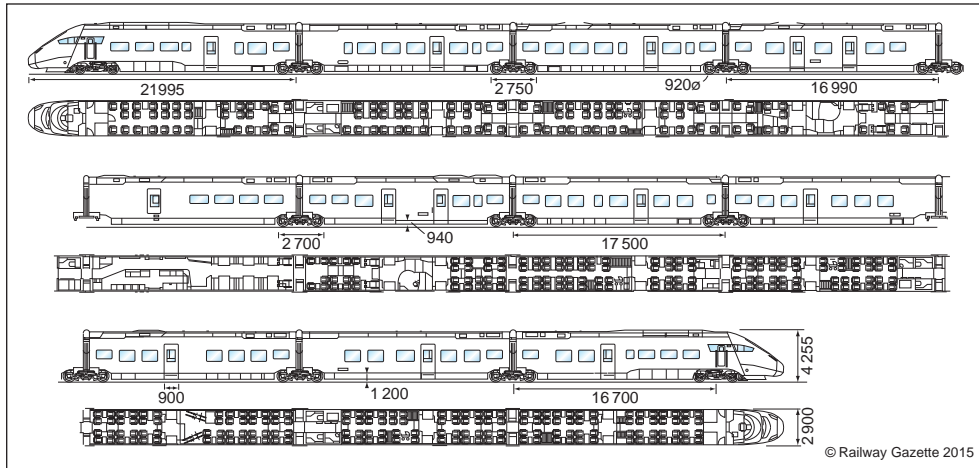

Fig 1. SBB's 11-car Giruno trainsets will have seats for over 400 passengers.

The timetable is based on the number of paths through the base tunnel: there will be six freight and two passenger paths per hour in each direction, with passenger trains timed at 200 km/h. All trains will be monitored from an operations control centre located in Pollegio; this was formally opened in May 2014.

A 3 h Zürich – Milano timing will be possible in 2020-21, with hourly departures planned. Domestic inter-city trains via the Gotthard will run at half-hourly intervals, with Zurich – Lugano timings cut to 1 h 50 min. Basel – Milano trains will be timed at around 4 h via the Gotthard or Lötschberg routes.

For domestic passengers there will be no direct trains from Zürich to Locarno, but Tilo S-Bahn services to the resort will connect at Bellinzona with all EuroCity and domestic inter-city trains every 30 min. The Lugano – Locarno

trip will take about 30 min.

SBB had originally planned to cut the Zürich – Milano timing to 2 h 40 min, but this appears unlikely for the foreseeable future. This timing assumed that tilting trains would be used, but it would also require a second Zimmerberg tunnel to be built. Even then, pathing constraints on the approach to Milano would limit the options for shorter timings.

At the moment SBB carries around 9000 passengers a day on its Gotthard services. The faster and more frequent service from December 2016 is expected to attract more business, with traffic rising to 15000 passengers a day by 2020 and doubling by 2025.

### Over the top

Passenger services over the high-level route through the original Gotthard pass after the base tunnel opens

**15000**  
passengers

ARE EXPECTED TO BE CARRIED ON SBB'S GOTTHARD SERVICES EACH DAY BY 2020

have been the topic of much discussion. The route gives access to several popular mountain resorts, and SBB is required to continue providing a service. In early 2014 Südostbahn submitted a plan to run hourly services between Arth-Goldau and Lugano in competition with SBB, but the transport ministry rejected the proposal later that year.

Under the current concession that SBB holds to operate national long-distance services an hourly train over the old Gotthard route is envisaged when the base tunnel opens. However, the concession falls due for renewal in 2017, and the federal transport ministry is expected to determine if the Gotthard pass service will be designated as a regional operation that qualifies for subsidy.

From the December 2016 timetable change SBB will run an hourly Regional Express train from Lugano or Bellinzona to Erstfeld. From the northern end passengers can expect InterRegio trains from Basel and Zürich to Erstfeld, with 'Sprinter' trains from Erstfeld for commuters in the morning and evening to Zug and Zürich. At weekends and peak holiday periods some trains from Zürich or Basel will be extended to Göschenen to connect with the metre gauge Matterhorn-Gotthard Bahn to Andermatt.

Discussions are in progress between SBB, the ministry, and the cantons of Uri and Ticino to decide on an economic but attractive service pattern from 2017 onwards. ■

## Freight targets may not be met

The main rationale behind construction of the Gotthard base tunnel — and its sister Lötschberg base tunnel — rests largely on the Swiss government's commitment to switch transit freight from road to rail. SBB will have 260 freight train paths a day available compared with a maximum of 180 over the Gotthard pass.

No longer will trains have to halt to attach additional locomotives for the 2.6% grades that take trains up to 1150 m above sea level. The new route lies just 550 m above sea level, with grades reduced to 1.25%. Not only that, but the route will be 30 km shorter. Whereas trains are currently limited to 1600 tonnes, in future the drawbar limit will rise to 2000 tonnes, with normal train length set at a maximum of 750 m.

Journey time from Basel to Chiasso will be cut by 25 min from December 2016 to an even 5 h, with 4 h 35 min attained in 2020. The Basel – Luino trip

will come down to 4 h 45 min by the same date.

All of this should translate into lower operating costs that can be set against the SFr12.2bn price of the Gotthard base tunnel.

Formal goals have been set by the Swiss government for transfer of transit freight from road to rail, but the number of lorries transiting Switzerland in 2014 was 1.03 million, 1.6% less than in 2013 but still 383000 more than the target set for 2018. Whether the advent of the base tunnels will suffice to attract sufficient lorry freight to rail for the target to be met is open to question, and the Swiss government is reportedly considering what other measures may be needed.

On the other hand, the volume of transit rail freight in 2014 rose by 3.5% to more than 26 million tonnes, with increases in wagonload and unaccompanied intermodal traffic; rolling motorway traffic was almost unchanged

over 2013 with 109000 lorries carried.

Of particular interest was the share of freight handled by SBB Cargo and SBB Cargo International. Measured in net tonnes, this rose to 58% following DB Schenker Rail's 2013 decision to switch its Gotthard transit freight contract from BLS Cargo to SBB Cargo. BLS Cargo continues to use the route, along with Crossrail, Transalpin, DB Schenker CH, Railcare and TX Logistik. ■

Although rail freight passing through Switzerland on the north-south corridors rose by 3.5% in 2014, the government target for transfer of traffic from road to rail may not be met, even after the Gotthard Base Tunnel opens.



# INTELLIGENCE Analysis



All trains operating over the Gotthard line must now be equipped for ETCS Level 2, including SBB's Roger 1000 infrastructure monitoring vehicle.

services start running as soon as the line opens, whereas SNCF would prefer to wait for the December 2017 timetable change. ■

## SWITZERLAND

### Level 2 on the Gotthard

During the night of August 15-16, Swiss Federal Railways successfully switched over the first section of its Gotthard corridor to ETCS Level 2. This is the first changeover to ETCS on Switzerland's conventional network, as opposed to new lines, and thus marks a significant step in the national ETCS roll-out programme.

The 19 km section between Brunnen and Erstfeld is the first part of this important north-south transit corridor to be converted, as it forms the northern approach to the Gotthard Base Tunnel, which is also being equipped with Level 2. Including the construction of electronic interlockings at Altdorf and Rynächt by AlpTransit Gotthard AG, it is part of the work which SBB says is needed to permit the operation of six freight and two passenger trains per hour in each direction through the base tunnel when it opens next year.

The Castione – Bodio section on the southern approach will be switched over to ETCS with effect from November 1, following completion of another interlocking at Pollegio. ETCS will also be introduced at Giubiasco/San Antonino on June 26 2017, and through the Ceneri Base Tunnel when that is commissioned in 2020.

In the revised TEN-T core network adopted in October 2013, the Gotthard route forms a key part of the Rhine-Alpine corridor, which under the official

ETCS deployment plan is scheduled to be fully equipped by the end of this year. However, the European Commission confirmed last year that some sections in Germany and Italy would not be ready before 2020.

According to SBB, the Gotthard line was blocked overnight for 9 h during the commissioning process, with passenger services replaced by buses and freight trains diverted via the Lötschberg route. The line reopened at 08.00, allowing the Sunday passenger services to operate without any problems. A bigger test for the new signalling came with the resumption of transit freight traffic on the following Monday, but SBB reports that 'it all worked very well', with no significant issues. During an initial shakedown period line speeds are being limited to 80 km/h between Flüelen and Erstfeld, but this was due to be reviewed at the beginning of September.

The changeover comes almost exactly three years after SBB and its contractors ceremonially installed a Eurobalise at Airolo to mark the start of the line-side fit out phase of the national ETCS programme. This will see much of the network equipped with Level 1 Limited Supervision to replace the legacy ZUB train warning system (RG 6.10 p36), and Level 2 on selected corridors. While the work was originally expected to be completed within a decade, SBB now says the full transition to ETCS is likely to take around 20 years.

With the installation of lineside equipment progressing faster than the fitting of rolling stock, some operators expressed concern that the switchover would prevent them using non-equipped locomotives or heritage rolling stock on charter trains over the Gotthard corridor. This is an inevitable consequence of the migration process, but the pressure should start to ease as more routes and trains are equipped. ■

## POINTERS

Bolloré Group and the governments of **Benin** and **Niger** signed a concession agreement on August 13 for the construction and operation of a railway from Cotonou to Niamey. This project involves rehabilitation of the metre-gauge Cotonou – Parakou line, and the construction of a 574 km extension. 'Both presidents view it as a priority for their national infrastructure', said Prime Minister of Benin Lionel Zinsou. 'Never has there been such an important investment in a West African country.'

**Norwegian** Infrastructure manager Jernebaneverket is looking to encourage new operators to provide services at its Ganddal rail freight terminal in Stavanger and the Brattøra terminal in Trondheim. The project is a trial at the behest of the Ministry of Transport & Communications, which wants to introduce competition in the market. If it is successful, all 12 JBV-owned freight terminals would be opened up to multiple operators from 2017.

Following a meeting with Inter-American Development Bank officials in Washington DC last month, Minister of the Interior & Transport Florencio Randazzo said that the Argentinian government was exploring new opportunities to finance electrification of the San Martín and Belgrano Sur commuter networks in **Buenos Aires**. IDB is already funding electrification of the Roca route to La Plata, which the government hopes to complete before the end of this year.

The Hellenic Republic Asset Development Fund announced on August 13 that a deadline of December 2015 has been agreed for binding offers to take over **Greece's** state-owned operator TrainOSE and rolling stock maintenance contractor Rosco. HRADF has reportedly received firm expressions of interest from SNCF, Russian Railways and Romania's Grampet Group for a 100% stake in the operator while Alstom, Siemens and an RZD-led consortium expressed an interest in acquiring Rosco.

Having reopened the 200 km Palmira – La Tebaida route in July, Ferrocarril del Pacifico of **Colombia** is looking to increase freight traffic on the 914 mm gauge network from 25 000 tonnes/month to 80 000 tonnes/month in 2016 (RG 8.14 p30).

The US Trade & Development Agency has awarded a grant of \$650 000 to ANPTrihos, the national association of passenger rail operators in **Brazil**, to develop 'a roadmap and implementation plan' for the adoption of real-time video monitoring by both public and private-sector operators. This will involve the identification of technologies as well as the definition of standards and protocols.

Under an agreement signed with **SNCF Réseau** and local authorities, the Axéreal co-operative of grain producers is to meet one-third of the €4m cost of track renewals required to keep the Vendôme – Montoire-sur-le-Loir – Troo line open to freight traffic, with the infrastructure manager undertaking to maintain the route for a period of 30 years.

The government of **Bangladesh** has agreed to fund a feasibility study into a railway connecting a planned power generation complex at Matarbari, including two coal-fired power stations, to the BR network. The study would also assess options for upgrading the Chittagong – Dohazari line and construction of an inland intermodal terminal at Dhirassam.

A problem with oil seals on the bogie frames has led to the temporary suspension of test running of **JR Kyushu's** Free Gauge Train (RG 11.14 p12). The trainset had accumulated more than 30 000 km of test running on both 1 067 mm and 1 435 mm gauge tracks, passing through gauge-changing facilities between the Kyushu Shinkansen and the Kagoshima Line more than 400 times before the problems emerged.

An agreement has been reached between the **Indian** government and the state of Odisha to share the cost of constructing 177 km of the planned Rs30bn, 289 route-km broad gauge line from Khurda Road, south of the state capital Bhubaneswar, to Bolangir.